

**GENERAL  
CATALOGUE  
2017**



**Your Gateway to Excellence**





**This general catalogue has been committed to:**

**Mrs/Mr** \_\_\_\_\_

**Company** \_\_\_\_\_

**address** \_\_\_\_\_

**on date** \_\_\_\_\_

**by our**

**EDITION EN 01/17**



**GENERAL INFORMATION**

**1**

**2/2 DIRECT ACTING**

**2**

**3/2 DIRECT ACTING**

**3**

**2/2 SERVO-ASSISTED**

**4**

**ANGLE SEAT VALVES**

**5**

**PINCH VALVES**

**6**

**SOLENOID PILOTS**

**7**

**COILS**

**8**

**ACCESSORIES**

**9**

**SPARE PARTS**

**10**



- 1.1** Introduction
- 1.2** Type number composition
- 1.3** Construction details
- 1.4** Seal material
- 1.5** Media compatibility
- 1.6** Electrical features
  - 1.6.1 Protection class
  - 1.6.2 Insulation class
  - 1.6.3 Service
  - 1.6.4 Power
- 1.7** Units of measure
- 1.8** Flow calculation
- 1.9** Technical tables
  - 1.9.1 Pressure
  - 1.9.2 Viscosity
  - 1.9.3 Temperature
  - 1.9.4 Steam
  - 1.9.5 Specific gravity
- 1.10** Response time
- 1.11** P.E.D. Directive (2014/68/UE)
- 1.12** Operating instructions and installation
- 1.13** Model identification





## 1.1 Introduction



The solenoid valves illustrated in this catalogue have applications in all industrial sectors, being compatible with a vast range of fluids. The quality of the materials used and the precise engineering of the parts, coupled with rigorous testing of the large production guarantees their service capability.

In addition to the standard versions illustrated here, we are able to offer alternative designs to resolve specific problems.



## 1.2 Type number composition for servo-assisted versions

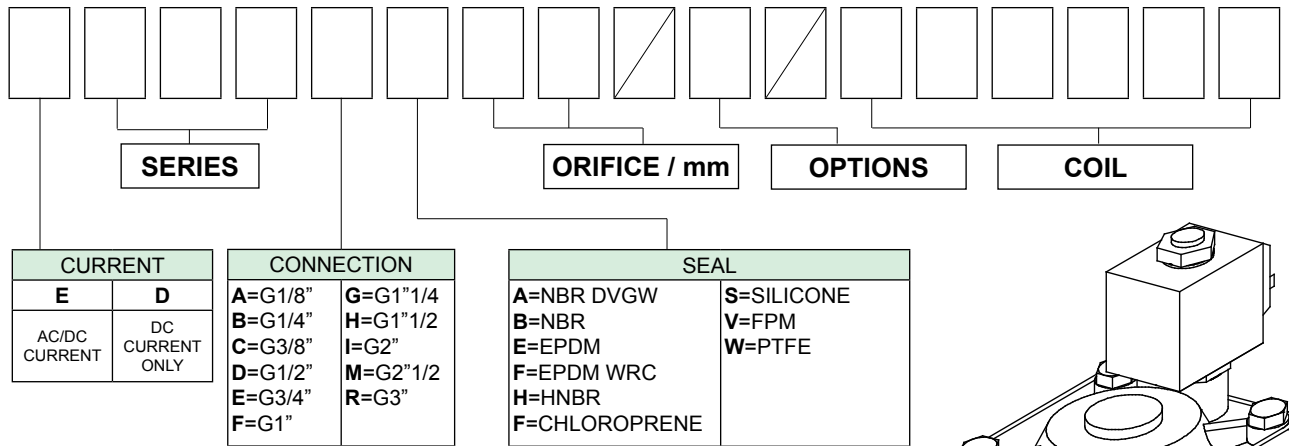

Example :  
**E207IV50///20E**

Solenoid valve suited to work in alternative or direct current 2/2 normally open, 2"BSP connections, FPM seal, orifice 50 mm, coil width 30mm, class F insulation, power consumption 15VA, voltage 220-230V 50/60Hz.

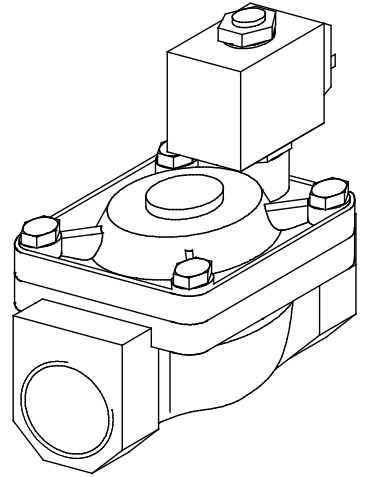

## 1.2 Type number composition for direct-acting versions

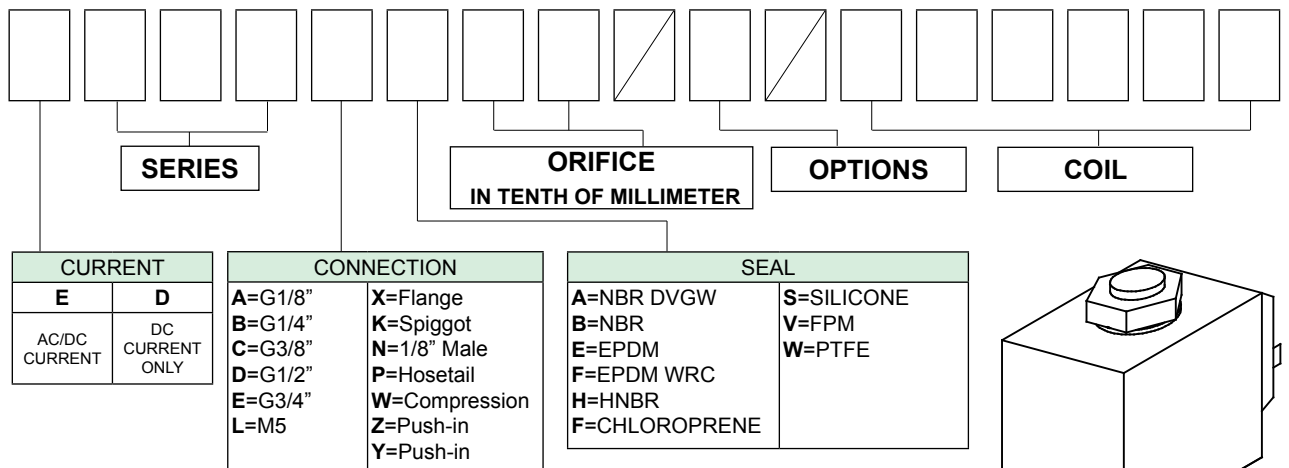

Example :  
**E105AB15///301**

Solenoid valve suited to work in alternative or direct current 2/2 normally closed, 1/8"BSP connections, NBR seal, orifice 1,5mm, coil width 22mm, class F insulation, power consumption 6,5W, voltage 24V DC.

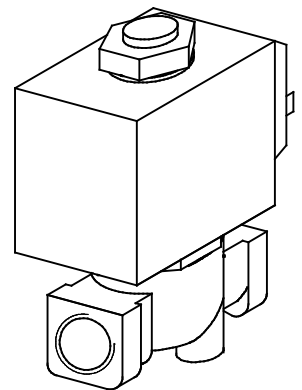

## Type number composition for angle seat valves

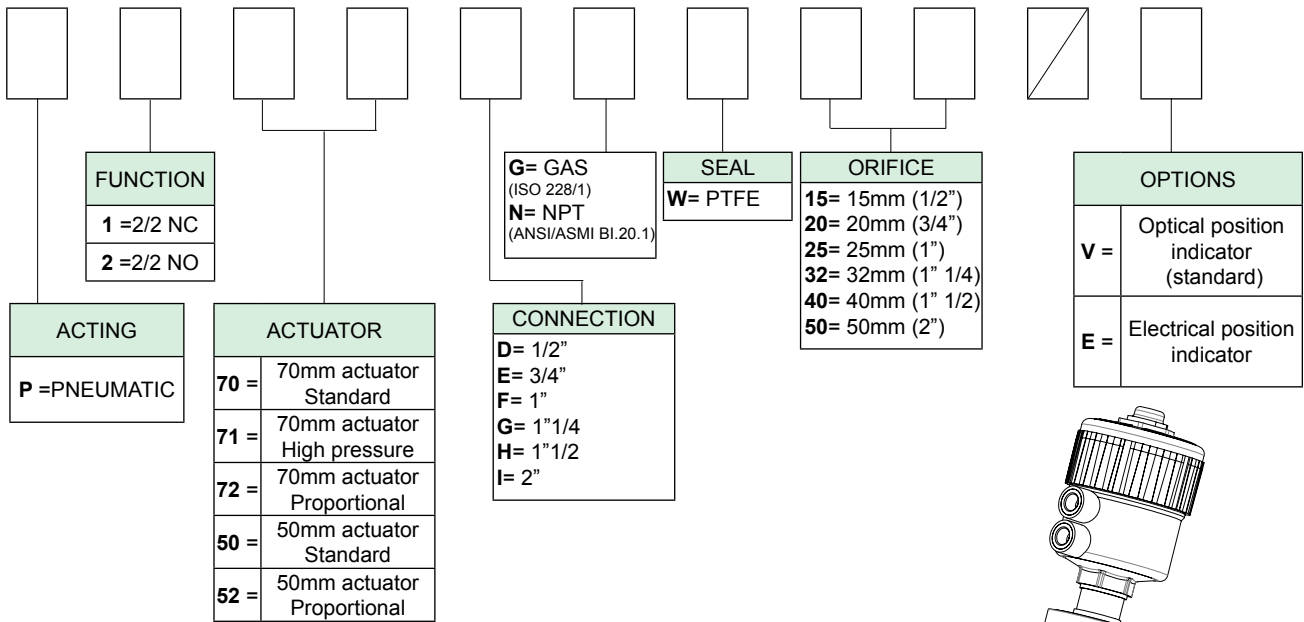

Example :

**P170DGW15/E**

Angle seat valve 2/2 NC actuator Ø70,

G1/2" connection, PTFE seals, electrical position indicator

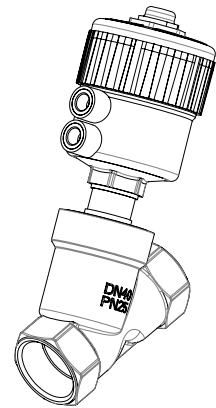

## Type number composition for coils

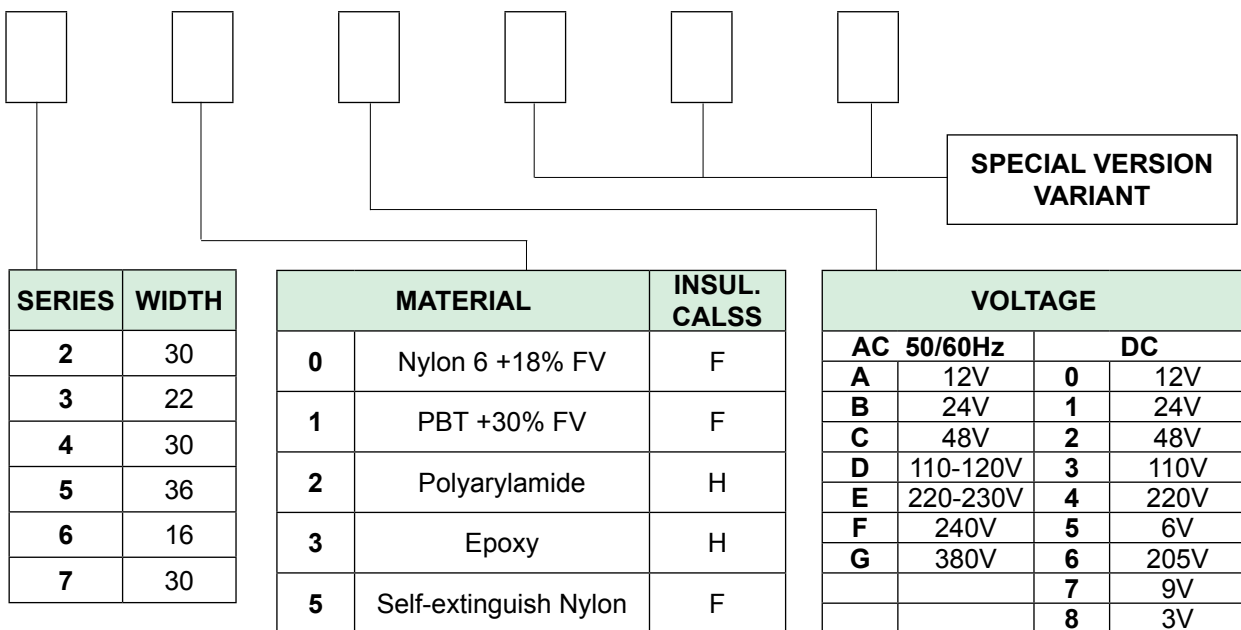

Example :

**30B**

Coil width 22mm in Nylon 6+18% Fibre Glass

Insulation class F Voltage 24V 50/60Hz Power 8VA

### 1.3 Construction details

Solenoid valves are equipment to control media in pressure. Their action is to either open or close the interception device, directly or indirectly, when the coil is energized.

**1**

The most important components of the solenoid valve are :

- 1.The **body valve**, which has an inlet and an outlet connection and an orifice for media flowing.
- 2.The **armature tube**, with the core, where the coil is fitted.
- 3.The **plunger**, which in some cases serves like a seal, sliding in the armature tube.
- 4.The **coil**, which produces the magnetic field required to move the plunger.

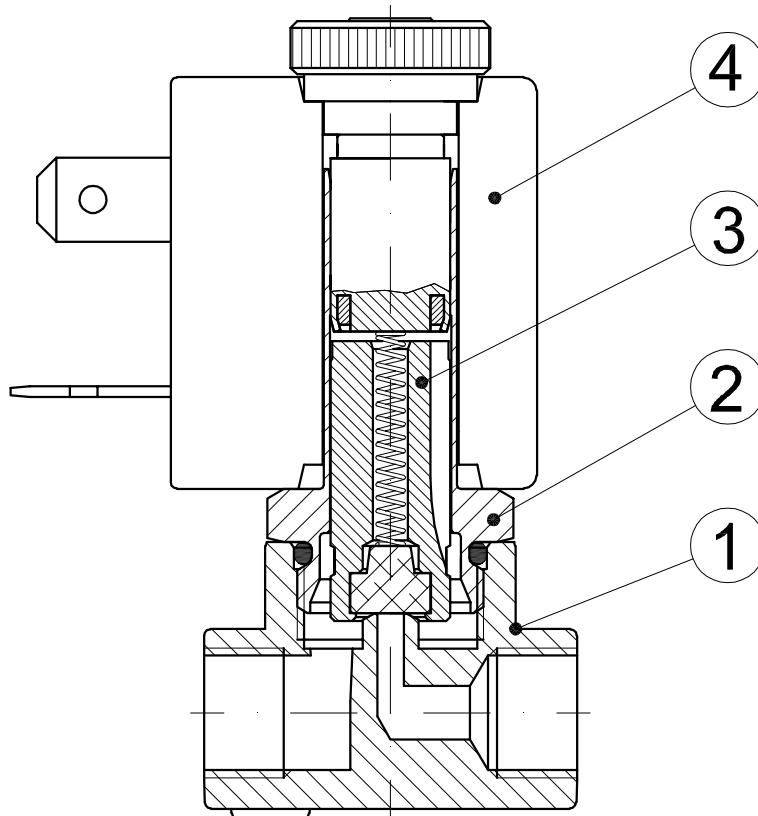

## 1.3.1 Methods of operation

### 2 way direct-acting

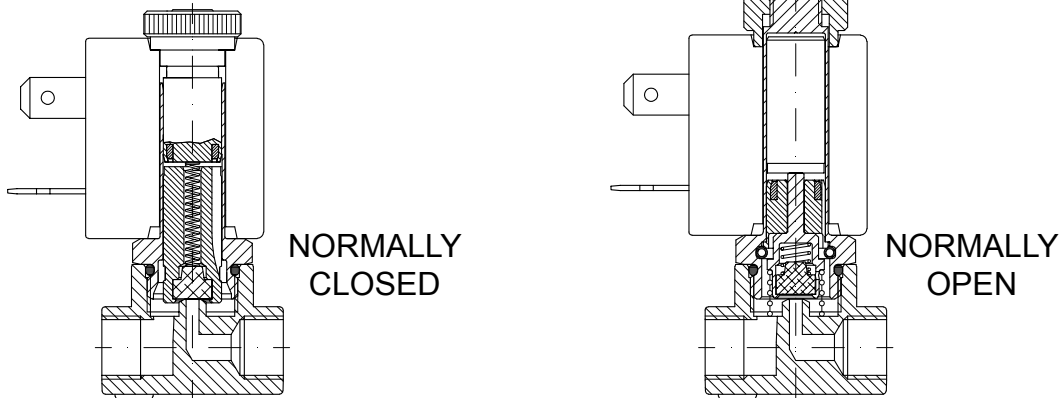

The 2 way solenoid valve has an inlet and an outlet connection within the valve body. It can be **normally closed** (2/2 NC). In this case the media is prevented from flowing through the orifice by the plunger seal. When connected to an electrical supply, the orifice opens allowing the inlet to feed the outlet port.

It can be **normally open** (2/2 NO). In this case the orifice is open, the inlet feeds through the outlet. When connected to an electrical supply the orifice is closed. The operation, in both cases depends only on the magnetic field produced by the coil. These solenoid valves are able to work at **zero pressure**.

### 3 way direct-acting

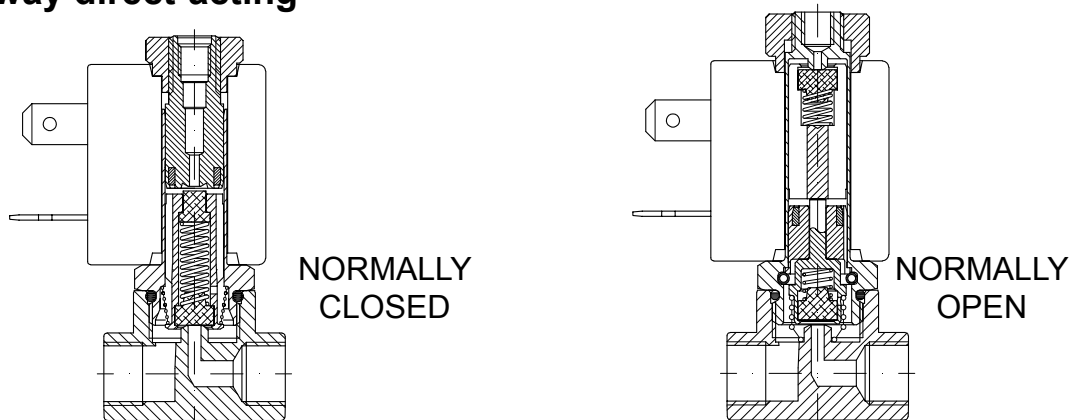

The 3 way solenoid valve has inlet and outlet connections in the body and an exhaust connection above the core.

It can be **normally closed** (3/2 NC). In this case the media is prevented from flowing through the inlet orifice by the plunger seal. The inlet and exhaust orifices are at each end of the plunger. When connected to an electrical supply, the inlet orifice opens feeding the user port. The exhaust is closed.

It can be **normally open** (3/2 NO). In this case when the coil isn't energized the inlet orifice is open to the user port. Exhaust port is closed. When connected to an electrical supply, the inlet orifice closes, at the same time the exhaust port is opened and connected with the user port. In both cases, the operation depends only on the magnetic field produced by the coil. These solenoid valves are able to work at zero pressure.

## Servo-assisted action

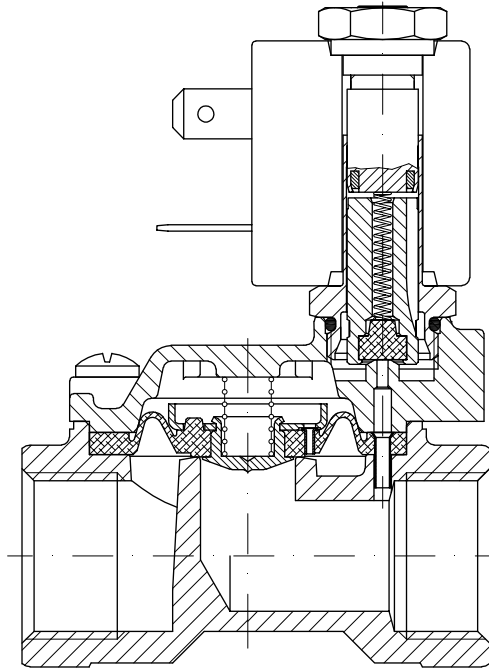
**1**

With larger orifices, static pressures increase, and it's still necessary that the magnetic field produced by the coil is able to control these forces. This is achieved by using servo-assisted action in the solenoid valve.

In this design the media pressure helps to keep the main valve seal closed.

The **normally closed** design (2/2 NC) has an inlet and outlet connection in the valve body. When the coil is not energized, the flow is blocked by the main seal, which could be either a diaphragm or a piston design.

In this mode the media flows through a small hole in the diaphragm or piston and helps close the valve. When the coil is energized the pilot orifice opens, allowing the media above the main seal to exhaust and the main valve seal to open.

This type of solenoid valve needs a minimum differential pressure to work.

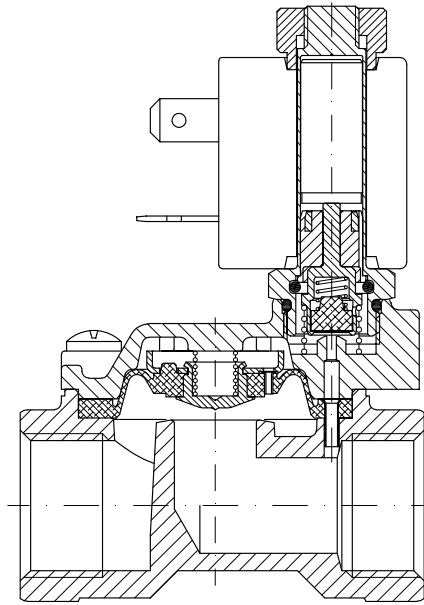

The **normally open (2/2 NO)** version has an inlet and outlet connection in the valve body. With larger orifices, static pressures increase, and it's still necessary that the magnetic field produced by the coil is able to control these forces. This is achieved by using servo-assisted action in the solenoid valve. In this design the media pressure helps to keep the main valve seal open. When the coil isn't energised, the flow is not interrupted by the main seal, which could be either a diaphragm or a piston design. In this mode the media flows through a small hole in the diaphragm or piston and helps the valve to open. When the coil is energised the pilot orifice closes, allowing the media above the main seal to pressurise and the main valve seal to close.

This type of solenoid valve needs a minimum differential pressure to work.

### **Assisted-lift diaphragm**

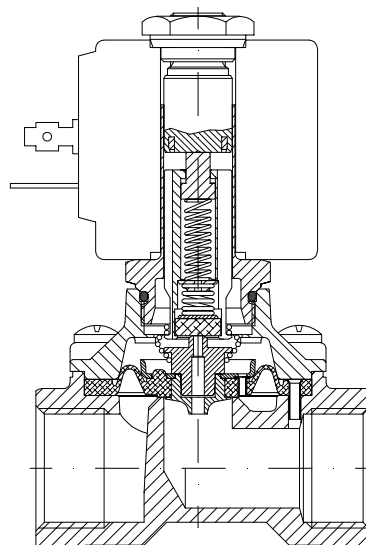

They are available with an **assisted lift** design pilot operated by diaphragm and **normally closed (2/2 NC)**. In these models the plunger is mechanically attached to the diaphragm and controls the central pilot orifice and the stroke of the main seal. This design allows the valve to work at zero differential pressure.

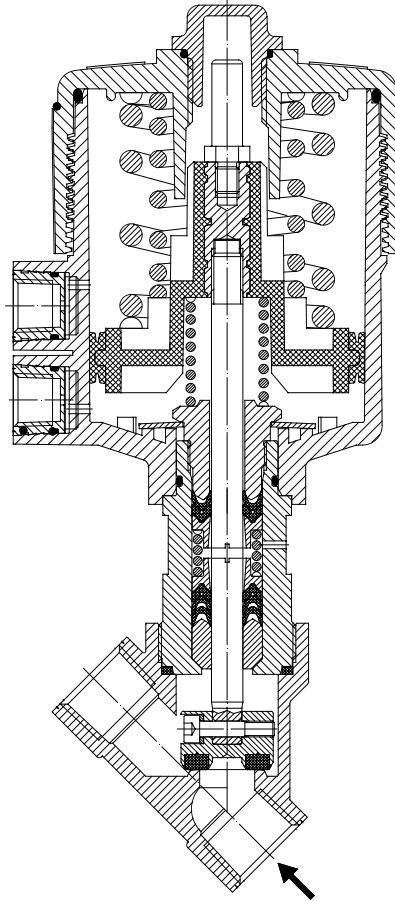

## Angle seat valves

**1**

This type of valve is controlled by a pilot fluid supplied to the actuator by means of a pilot valve.

A stem connect the closure device to the control member of the actuator.

The spring acting on the control member forces the closure device down into the closed position on the valve seat.

The pilot supply overcomes the spring force to lift the control member into the open position.

These valves are mainly suitable for contaminated or extremely viscous process fluids.

## 1.4 Seal materials

Designation	Commercial denomination	General characteristics	Typical applications
NBR (Acrylic-nitrile butadiene)	BUNA -N PERBUNAN ELAPRIM JSR-N	A synthetic elastomer with good mechanical and thermal properties. Good resistance to oils. Poor resistance to ozone and atmospheric derivatives.	Water (max T=+70°C) Air (max T=+90°C) Mineral oils and their derivatives, hydrocarbons, methane, ethane, propane, butane, kerosene oil, fuel oil.
EPDM (Ethylene-propylene-dylene )	BUNA- AP DUTRAL NORDEL	A synthetic elastomer derived from the co-polymerization of ethylene and propylene. Suitable for use with non-phosphoric based hydraulic fluids(hold). Water and steam to a max. temp. of 140°C. Not suitable for use with mineral based products. (oil, grease , fuel oils and petrol)	Hot water and steam. Detergents. Potassium and sodium solutions. Hydraulic fluids. Polarised solvents. Skydrol 500 and 700 *
FPM (Fluorocarbon)	VITON TECNOFLON FLUOREL	A synthetic elastomer derived from flour-propylene. Excellent resistance to the high temp. Excellent resistance to ozone, oxygen, mineral oils, synthetic hydraulic oil, petrol, hydrocarbons and many other chemicals. Not suitable for use with superheated steam.	For general use up to +130°C
PTFE (Polytetrafluorethylene)	TEFLON	Thermoplastic material used also filled with a mineral resin. Excellent resistance to many chemicals. Optimum high temp. resistance. Poor resilience, improved by adding the mineral filling.	For general use up to +160°C

## 1.5 Media compatibility

The following table has the scope to provide an indication of the general characteristics with regard to the compatibility with the different materials and media. To determine the compatibility with corrosive fluids it is important to know all the data relative to :  
temperature, concentration and media composition.







1

MEDIA	Brass	Stainless steel	NBR	EPDM	FPM	PTFE
Acetone	•	•	-	•	-	•
Acetylene	•	•	-	•	•	•
Argon hold	•	•	-	•	•	•
Benzol	•	•	-	-	-	•
Butane	•	•	-	-	•	•
Calcium monoxide	•	•	•	•	•	•
Carbon dioxide (liquid)	-	•	-	-	-	•
Carbon disulphide	•	•	-	-	-	•
Chloroform	•	•	-	-	-	•
De-ionised water	-	•	•	•	•	•
De-mineralised water	-	•	•	•	•	•
Dry carbon dioxide (gas)	•	•	•	•	•	•
Ethane	•	•	•	-	•	•
Ethanol	•	•	-	-	-	•
Ethyl acetate	•	•	-	-	-	•
Ethyl chloride	•	•	•	•	•	•
Ethylene glycol	•	•	•	•	•	•
Formaldehyde	•	•	•	•	•	•
Freon	•	•	-	-	-	•
Fuel oil	•	•	•	-	•	•
Glycerine	•	•	•	-	•	•
Hard water	•	•	•	•	•	•
Helium	•	•	•	-	•	•
Heptane	•	•	•	-	•	•
Hexane	•	•	•	-	•	•
Hot water <75°C	•	•	•	•	•	•
Hot water and steam <140°C	•	•	-	•	-	•
Hydrogen	•	•	-	-	•	•
Hydrogen dioxide	-	•	-	-	•	•
Isobutane	•	•	•	-	•	•
Isopentane	•	•	•	-	•	•
Methane	•	•	•	-	•	•
Methanol	•	•	-	•	-	•
Methyl chloride	•	•	-	-	-	•
Mineral oil	•	•	•	-	•	•
Natural gas	•	•	•	-	•	•
Neon	•	•	•	-	•	•
Nitrobenzene	•	•	-	-	-	-
Nitrogen	•	•	•	•	•	•
Oxygen	•	•	•	-	•	•
Pentane	•	•	•	•	•	•
Petrol	•	•	-	-	•	•
Propane-n	•	•	•	-	•	•
Soapy water	•	•	•	-	•	•
Toluene	•	•	-	-	•	•
Trichlorethylene dry	•	•	-	-	•	•
Vinegar	•	•	-	•	-	•
Water with glycol	•	•	-	-	•	•
Xilol	-	•	-	-	•	•

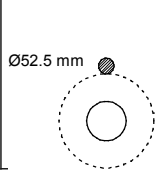
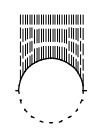
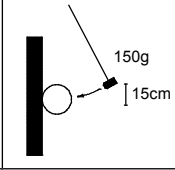
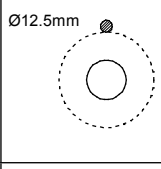
• Compatible    - Not compatible

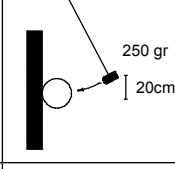
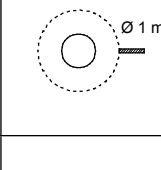
## 1.6.1 Protection class IP.....

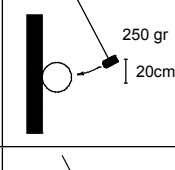
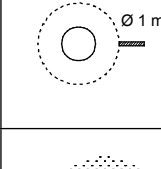
Compliance with the standard DIN 40050 for the electrical protection at 1000 Volt AC and 1500 Volt DC

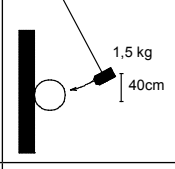
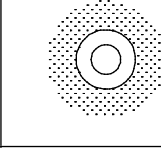
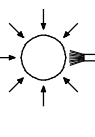
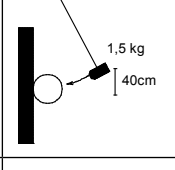
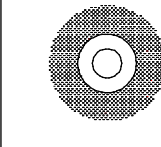
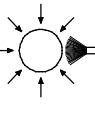
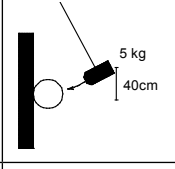
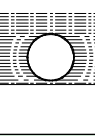
1st number: protection against solid bodies			2nd number: protection against liquids			3rd number: mechanical protection		
IP	Testes	Description	IP	Testes	Description	IP	Testes	Description
0		No protection	0		No protection	0		No protection
1		Protection against solid bodies larger than d.50 mm (ex. involuntary contact by hand)	1		Protection against the vertical fall of water drops (condensation)	1		Impact energy 0.225 joules
2		Protection against solid bodies larger than d.12mm (ex. finger contact)	2		Protection against the fall of water drops up to 15° from the vertical	2		Impact energy 0.375 joules
3		Protection against solid bodies larger than d. 2,5mm (ends of tools, wires)	3		Protection against the fall of water drops and rain up to 60° from the vertical	3		Impact energy 0.500 joules
4		Protection against solid bodies larger than d. 1 mm (ends of tools, thin wires)	4		Protection against water jets from all directions	4		Impact energy 2.00 joules
5		Protection against dust (no harmful deposits)	5		Protection against forced water jets from all directions	7		Impact energy 6.00 joules
6		Total protection against dust	6		Protection against water similar to waves	9		Impact energy 20.00 joules
			7		Protection against water immersion			

In the case of solenoid valves, use only the first two number

### 1.6.2 Insulation class according to CEI 15-26

Insulation class	Temperature °C
Y	90
A	105
E	120
B	130
F	155
H	180
200	200
220	220
250	250

The indicated temperature is the effective temperature of the insulation and not the overtemperature.

### 1.6.3 Service

The coils are normally expected to be used in continuous service (ED100%).

Definition of “Continuous service”: when the electrical connection time exceed the thermal constant of the coil by approx. .

As a general rule, the continuous service corresponds to an electrical connection time that is equal or higher than 15 minutes.

It's possible, for non-continuous service (e.g. ED50%), either to have coils at powers that are higher than the standard ones, or to use the coils with an ambient temperature higher than the ones indicated.

$$ED = \frac{\text{connection time}}{(\text{connection time} + \text{disconnection time})}$$

$$EXAMPLE = \frac{5' \text{ (connection time)}}{5' \text{ (connection time)} + 5' \text{ (disconnection time)}} \times 100 = ED50\%$$

## 1.6.4 Coils power

The power (P) indicated is referred to a temperature of 20°C.  
For DC current it is as follows:

$$P(\text{Watt}) = V(\text{Volt}) \times I(\text{Ampere}) ; P = \frac{V^2}{R} \text{ (Volt)}$$

In the case of AC current, the value is referred to the apparent power during inrush (connection moment) and during holding.

$$P(\text{VA}) = V(\text{Volt}) \times I(\text{Ampere})$$

In the case of AC current, voltage and current are not in phase with each other. Phase angle between current and voltage is shown by the angle  $\phi$  of the resistance triangle (the three sides represent: resistance, reactance and impedance of the circuit).

In the case of AC current the power showed in Watt become:

$$P(\text{watt}) = V(\text{Volt}) \times I(\text{Ampere}) \times \text{power factor } \phi$$

power factor  $\phi$  = power factor is always less than 1

The power, or electric input, in a AC current solenoid valve, is higher during inrush while it decreases when the plunger's stroke is complete. In the DC current solenoid valve, as the power depends from the coil's Ohmic resistance, the power is the same during inrush and also when the plunger's stroke is complete too.

## 1.7 Units of measure

In the international system (SI) the physical and technical units are validated as follows :

Unit of length	:	Meter	(symbol m)
Unit of mass	:	Kilogram	(symbol Kg)
Unit of time	:	Second	(symbol s)
Unit of electrical current	:	Ampère	(symbol A)
Unit of temperature	:	Kelvin	(symbol K)
Unit of luminosity	:	Candle	(symbol cd)

### Pressure

Old measuring units :

Kilopond per cm <sup>2</sup>	Kp/cm <sup>2</sup>
Meter of water column	mH <sub>2</sub> O
Millimeter of mercury column	mmHg
Metric Atmosphere	at
Atmosphere	atm

They were replaced in the SI from Pascal.

One Pascal corresponds to the pressure of 1 Newton, which is acting on the area of 1 m<sup>2</sup>.

$$1 \text{ Pascal} = 1 \text{ N} / 1 \text{ m}^2$$

Unit Pa is a very low value and for standard industrial applications, the Bar (symbol bar) is used.

$$1 \text{ bar} = 0.1 \text{ MegaPascal (symbol Mpa} = 1.000.000 \text{ Pa)}$$

The conversion from the old unit of measure to the new one (SI) is the following :

$$1 \text{ Kp/cm}^2 = 0.981 \text{ bar}$$

$$1 \text{ bar} = 1.02 \text{ Kp/cm}^2$$

The conversion in the SI unit is also possible where the metric system is not yet used.

$$\begin{aligned} \text{Conversion : } & 1 \text{ bar} = 14.50 \text{ psi} \\ & 1 \text{ psi} = 0.07 \text{ bar} = 7.000 \text{ Pa} \end{aligned}$$

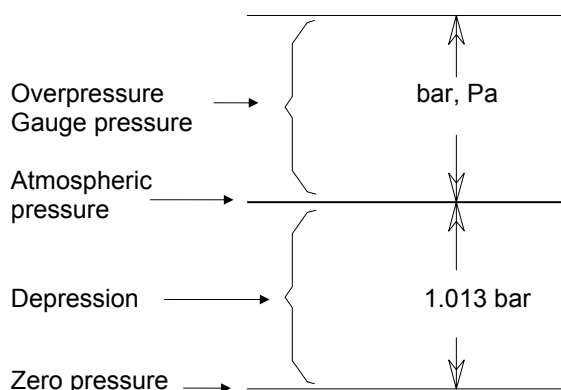

Pressure values, except specific references, are referred to the atmospheric pressure

## 1.8 Flow calculation

Each solenoid valve has a flow coefficient (Kv).

It's possible, with this data, to calculate the flow. Given the loss of flowing pressure (pressure drop), the media type and the working pressure it's possible to calculate the flow rate.

This flow coefficient is determined by way of experimentation according to the standard VDE 2173 and it represents the quantity of water discharged from the solenoid valve with a pressure difference of 1 bar at a temperature between 5°C and 40°C.

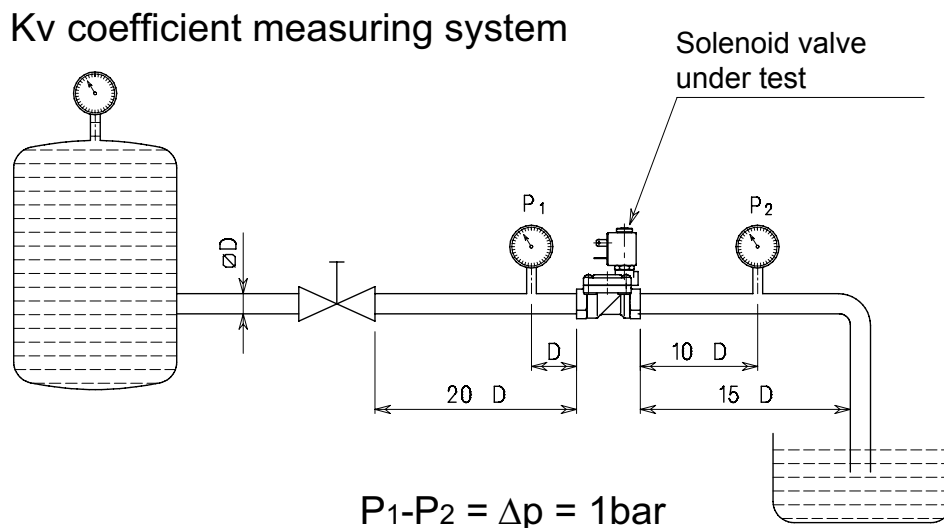

Kv	=	m <sup>3</sup> /h	Flow coefficient
Q	=	m <sup>3</sup> /h	Flow
Q <sub>n</sub>	=	m <sup>3</sup> n/h	Normal flow (20°C 760mm Hg)
P <sub>1</sub>	=	bar	Inlet pressure (Gauge pressure + 1)
P <sub>2</sub>	=	bar	Outlet pressure (Gauge pressure + 1)
Δp	=	bar	Pressure drop (differential pressure between inlet & outlet )
ρ	=	Kg/dm <sup>3</sup>	Relative density referred to water (Water at 4°C = 1)



$\rho_n$	=	Kg/dm <sup>3</sup>	Normal relative density referred to air
G	=	Kg/h	Mass
t	=	°C	Inlet media temperature
$V_1$	=	m <sup>3</sup> /Kg	Inlet specific volume
$V_2$	=	m <sup>3</sup> /Kg	Outlet specific volume referred to "P <sub>2</sub> " pressure and "t" temperature

Liquids :  $Q = K_v \sqrt{\frac{\Delta p}{\rho}}$

Gas :  $\Delta p = \Delta p < \frac{P_1}{2} \quad Q_n = 514 \times K_v \sqrt{\frac{\Delta p \times P_2}{\rho_n \times (273 + t)}}$

$\Delta p = \Delta p > \frac{P_1}{2} \quad Q_n = 257 \times K_v \frac{P_1}{\sqrt{\rho_n (273 + t)}}$

Air :  $\Delta p = \Delta p < \frac{P_1}{2} \quad Q_n = 26 \times K_v \sqrt{\Delta p \times P_2}$

$\Delta p = \Delta p > \frac{P_1}{2} \quad Q_n = K_v \times P_1 \times 13$

Steam :  $\Delta p = \Delta p < \frac{P_1}{2} \quad G = 31.6 \times K_v \sqrt{\frac{\Delta p}{V_2}}$

$\Delta p = \Delta p > \frac{P_1}{2} \quad G = 31.6 \times K_v \sqrt{\frac{P_1}{v_1}}$

## 1.9 Technical tables

### 1.9.1 Pressure

bar	N/cm <sup>2</sup>	MPa	Psi	bar	N/cm <sup>2</sup>	MPa	Psi
0.1	1	0.01	1.45	14	140	1.4	203.00
0.2	2	0.02	2.90	15	150	1.5	217.50
0.3	3	0.03	4.35	16	160	1.6	232.00
0.4	4	0.04	5.80	17	170	1.7	246.50
0.5	5	0.05	7.25	18	180	1.8	261.00
0.6	6	0.06	8.70	19	190	1.9	275.50
0.7	7	0.07	10.15	20	200	2.0	290.00
0.8	8	0.08	11.60	21	210	2.1	304.50
0.9	9	0.09	13.05	22	220	2.2	319.00
1.0	10	0.10	14.50	23	230	2.3	333.50
1.5	15	0.15	21.75	24	240	2.4	348.00
2.0	20	0.20	29.00	25	250	2.5	362.50
2.5	25	0.25	36.25	26	260	2.6	377.00
3.0	30	0.30	43.50	27	270	2.7	391.50
3.5	35	0.35	50.75	28	280	2.8	406.00
4.0	40	0.40	58.00	29	290	2.9	420.50
4.5	45	0.45	65.25	30	300	3.0	435.00
5.0	50	0.50	72.50	35	350	3.5	507.50
5.5	55	0.55	79.75	40	400	4.0	580.00
6.0	60	0.60	87.00	45	450	4.5	652.50
6.5	65	0.65	94.25	50	500	5.0	725.00
7.0	70	0.70	101.50	55	550	5.5	797.50
7.5	75	0.75	108.75	60	600	6.0	870.00
8.0	80	0.80	116.00	65	650	6.5	942.50
8.5	85	0.85	123.25	70	700	7.0	1015.00
9	90	0.90	130.50	75	750	7.5	1087.50
9.5	95	0.95	137.75	80	800	8.0	1160.00
10	100	1.00	145.00	85	850	8.5	1232.50
11	110	1.10	159.50	90	900	9.0	1305.00
12	120	1.20	174.00	95	950	9.5	1377.50
13	130	1.30	188.50	100	1000	10.0	1450.00

### 1.9.2 Viscosity

Kinematic viscosity centistokes cSt (mm <sup>2</sup> /s)	°Engler °E	Saybolt Universal Ssu	Redwood seconds n°1 SRW n°1
1	1	---	---
2	1.1	32.7	31
3	1.2	36	33.5
4	1.3	39	36
5	1.4	42.5	38.5
7	1.5	49	44
10	1.8	59	52
15	2.3	77.5	68
20	2.9	98	86
25	3.4	119	105
30	4	140	120
35	4.7	164	145
40	5.3	186	165
50	6.6	232	205
60	8	278	245
70	9.2	324	286
80	10.5	370	327
90	12	415	370
100	13	465	410

### 1.9.3 Temperature

°C	K	°F	°C	K	°F	°C	K	°F	°C	K	°F
-50	223	-58.0	1	274	33.8	51	324	123.8	105	378	221.0
-49	224	-56.2	2	275	35.6	52	325	125.6	110	383	230.0
-48	225	-54.4	3	276	37.4	53	326	127.4	115	388	239.0
-47	226	-52.6	4	277	39.2	54	327	129.2	120	393	248.0
-46	227	-50.8	5	278	41.0	55	328	131.9	125	398	257.0
-45	228	-49.0	6	279	42.8	56	329	132.8	130	403	266.0
-44	229	-47.2	7	280	44.6	57	330	134.6	135	408	275.0
-43	230	-45.4	8	281	46.4	58	331	136.4	140	413	284.0
-42	231	-43.6	9	282	48.2	59	332	138.2	145	418	293.0
-41	232	-41.8	10	283	50.0	60	333	140.0	150	423	303.0
-40	233	-40.0	11	284	51.8	61	334	141.8	155	428	311.0
-39	234	-38.2	12	285	53.6	62	335	143.6	160	433	320.0
-38	235	-36.4	13	286	55.4	63	336	145.4	165	438	329.0
-37	236	-34.6	14	287	57.2	64	337	147.2	170	443	338.0
-36	237	-32.8	15	288	59.0	65	338	149.0	175	448	347.0
-35	238	-31.0	16	289	60.8	66	339	150.8	180	453	356.0
-34	239	-29.2	17	290	62.6	67	340	152.6	185	458	365.0
-33	240	-27.4	18	291	64.4	68	341	154.4	190	463	374.0
-32	241	-25.6	19	292	66.2	69	342	156.2	195	468	383.0
-31	242	-23.8	20	293	68.0	70	343	158.0	200	473	392.0
-30	243	-22.0	21	294	69.8	71	344	159.8	205	478	401.0
-29	244	-20.2	22	295	71.6	72	345	161.6	210	483	410.0
-28	245	-18.4	23	296	73.4	73	346	163.4	215	488	419.0
-27	246	-16.6	24	297	75.2	74	347	165.2	220	493	428.0
-26	247	-14.8	25	298	77.0	75	348	167.0	225	498	437.0
-25	248	-13.0	26	299	78.8	76	349	168.8	230	503	446.0
-24	249	-11.2	27	300	80.6	77	350	170.6	235	508	455.0
-23	250	-9.4	28	301	82.4	78	351	172.4	240	513	464.0
-22	251	-7.6	29	302	84.2	79	352	174.2	245	518	473.0
-21	252	-5.8	30	303	86.0	80	353	176.0	250	523	482.0
-20	253	-4.0	31	304	87.8	81	354	177.8	255	528	491.0
-19	254	-2.2	32	305	89.6	82	355	179.6	260	533	500.0
-18	255	-0.4	33	306	91.4	83	356	181.4	265	538	509.0
-17	256	1.4	34	307	93.2	84	357	183.2	270	543	518.0
-16	257	3.2	35	308	95.0	85	358	185.0	275	548	527.0
-15	258	5.0	36	309	96.8	86	359	186.8	280	553	536.0
-14	259	6.8	37	310	98.6	87	360	188.6	285	558	545.0
-13	260	8.6	38	311	100.4	88	361	190.4	290	563	554.0
-12	261	10.4	39	312	102.2	89	362	192.2	295	568	563.0
-11	262	12.2	40	313	104.0	90	363	194.0	300	573	572.0
-10	263	14.0	41	314	105.8	91	364	195.8	310	583	590.0
-9	264	15.8	42	315	107.6	92	365	197.6	320	593	608.0
-8	265	17.6	43	316	109.4	93	366	199.4	330	603	626.0
-7	266	19.4	44	317	111.2	94	367	201.2	340	613	644.0
-6	267	21.2	45	318	113.0	95	368	203.0	350	623	662.0
-5	268	23.0	46	319	114.8	96	369	204.8	360	633	680.0
-4	269	24.8	47	320	116.6	97	370	206.6	370	643	698.0
-3	270	26.6	48	321	118.4	98	371	208.4	380	653	716.0
-2	271	28.4	49	322	120.2	99	372	210.2	390	663	734.0
-1	272	30.2	50	323	122.0	100	373	212.0	400	673	752.0
0	273	32.0									

### 1.9.4 Steam

Relative pressure (bar)	Absolute pressure (bar)	Temperature (°C)	Steam specific volume (m³/Kg)
---	<b>0.050</b>	<b>32.88</b>	<b>28.192</b>
---	<b>0.500</b>	<b>81.33</b>	<b>3.240</b>
<b>0.00</b>	<b>1.013</b>	<b>100.00</b>	<b>1.673</b>
<b>0.10</b>	<b>1.113</b>	<b>102.66</b>	<b>1.533</b>
<b>0.20</b>	<b>1.213</b>	<b>105.10</b>	<b>1.414</b>
<b>0.35</b>	<b>1.363</b>	<b>108.50</b>	<b>1.268</b>
<b>0.50</b>	<b>1.513</b>	<b>111.61</b>	<b>1.149</b>
<b>0.70</b>	<b>1.713</b>	<b>115.40</b>	<b>1.024</b>
<b>1.00</b>	<b>2.013</b>	<b>120.42</b>	<b>0.881</b>
<b>1.50</b>	<b>2.513</b>	<b>127.62</b>	<b>0.714</b>
<b>2.00</b>	<b>3.013</b>	<b>133.69</b>	<b>0.603</b>
<b>2.50</b>	<b>3.513</b>	<b>139.02</b>	<b>0.522</b>
<b>3.00</b>	<b>4.013</b>	<b>143.75</b>	<b>0.461</b>
<b>3.50</b>	<b>4.513</b>	<b>148.02</b>	<b>0.413</b>
<b>4.00</b>	<b>5.013</b>	<b>151.96</b>	<b>0.374</b>
<b>4.50</b>	<b>5.513</b>	<b>155.55</b>	<b>0.342</b>
<b>5.00</b>	<b>6.013</b>	<b>158.92</b>	<b>0.315</b>
<b>6.00</b>	<b>7.013</b>	<b>165.04</b>	<b>0.272</b>
<b>7.00</b>	<b>8.013</b>	<b>170.50</b>	<b>0.240</b>
<b>8.00</b>	<b>9.013</b>	<b>175.43</b>	<b>0.215</b>
<b>9.00</b>	<b>10.013</b>	<b>179.97</b>	<b>0.194</b>
<b>10.00</b>	<b>11.013</b>	<b>184.13</b>	<b>0.177</b>

## 1.9.5 Specific gravity

Liquid substances			Gases and vapours at 20°C and 1atm*		
Liquid	Temp. °C	Specific gravity Kg/dm <sup>3</sup>	Gases or vapour	Specific gravity	
				Relative density to air	gr/dm <sup>3</sup>
Acetone	25	0,787	Acetylene (ethyne)	0,90	1,085
Acetylene, liquid	70°F	0,38	Air	1,00	1,205
Alcohol, ethyl (ethanol)	25	0,787	Alcohol vapor	1,60	1,929
Alcohol, methyl (methanol)	25	0,791	Ammonia	0,59	0,711
Alcohol, propyl	25	0,802	Argon	1,38	1,663
Ammonia (aqua)	25	0,826	Benzene	2,70	3,249
Aniline	25	1,022	Butane	2,01	2,417
Benzene	25	0,876	Isobutene	1,94	2,338
Benzil	25	1,084	Carbon dioxide	1,52	1,830
Bromine	25	3,12	Carbon monoxide	0,97	1,165
Butane, liquid	25	0,601	Chlorine	2,49	2,996
Caustic soda 9% - NaOH	15	1,10	Cyclobutane	1,94	2,335
Caustic soda 18% - NaOH	15	1,20	Cyclopentane	2,42	2,919
Caustic soda 27% - NaOH	15	1,30	Cyclopropane	1,45	1,748
Caustic soda 47% - NaOH	15	1,50	Deuterium	0,07	0,084
Chloroform	25	1,469	Ethane	1,04	1,251
Ethane	-89	0,572	Ether vapor	2,59	3,116
Ether	25	0,716	Ethyl Chloride	2,23	2,687
Ethylene glycol	25	1,1	Ethylene (Ethene)	0,97	1,167
Formaldehyde	45	0,815	Fluorine	1,31	1,579
Freon R-11	25	1,48	Helium	0,14	0,166
Freon R-12	25	1,315	Heptanes	3,46	4,168
Freon R-22	25	1,197	Hexane	2,97	3,582
Fuel oil	60°F	0,893	Hydrogen	0,07	0,084
Gasoline, Vehicle	60°F	0,739	Hydrogen chloride	1,27	1,528
Hydrochloric acid 10%	15	1,05	Hydrogen sulfide	1,18	1,417
Hydrochloric acid 20%	15	1,10	Hydrofluoric acid	2,37	2,856
Hydrochloric acid 30%	15	1,15	Hydrochloric acid	1,26	1,520
Hydrochloric acid 40%	15	1,20	Illuminating gas	0,40	0,482
Kerosene	60°F	0,82	Isobutane	2,01	2,422
Mercury	25	13,633	Isopentane	2,48	2,988
Milk	15	1,035	Mercury vapor	6,94	8,363
Naphtha	15	0,667	Methane	0,55	0,667
Nitric acid 17%	15	1,10	Natural Gas (typical)	0,7 - 0,5	0,844 - 0,723
Nitric acid 25%	15	1,15	Neon	0,70	0,840
Nitric acid 47%	15	1,30	Nitrogen	0,97	1,165
Nitric acid 94%	15	1,50	Nitrous oxide	1,53	1,844
Octane	25	0,701	Octane	3,94	4,753
Olive Oil	15	0,703	Oxygen	1,10	1,331
Oxygen	-183	1,14	Ozone	1,66	2,000
Potassium Hydroxide 21%	15	1,2	Pentane	2,49	2,997
Potassium Hydroxide 49%	15	1,5	Propane	1,52	1,834
Propane	25	0,495	Propene (Propylene)	1,45	1,750
Sulphuric acid 27%	15	1,20	R-12	4,17	5,030
Sulphuric acid 50%	15	1,40	R-134A	3,52	4,244
Sulphuric acid 87%	15	1,80	Sulfur Dioxide	2,26	2,728
Sulphuric acid, pure	15	1,89	Water vapor	0,62	0,749
Turpentine	25	0,871	Xenon	4,53	5,459
Water, pure	4	1			
Water, sea	77°F	1,025			

\*) NTP - Normal Temperature and Pressure - is defined as air at 20°C and 1 atm

Specific gravity is the ratio between the density (mass per unit volume) of the actual gas and the density of air, specific gravity has no dimension. The density of air at NTP is 1.205 kg/m<sup>3</sup>.

## 1.10 Response time

The Response time ( $R_t$ ) of a solenoid valve is the period passing between the energisation (or de-energisation) of the coil and the moment when the outlet pressure reaches the 50% of its peak.

Example of a circuit test:

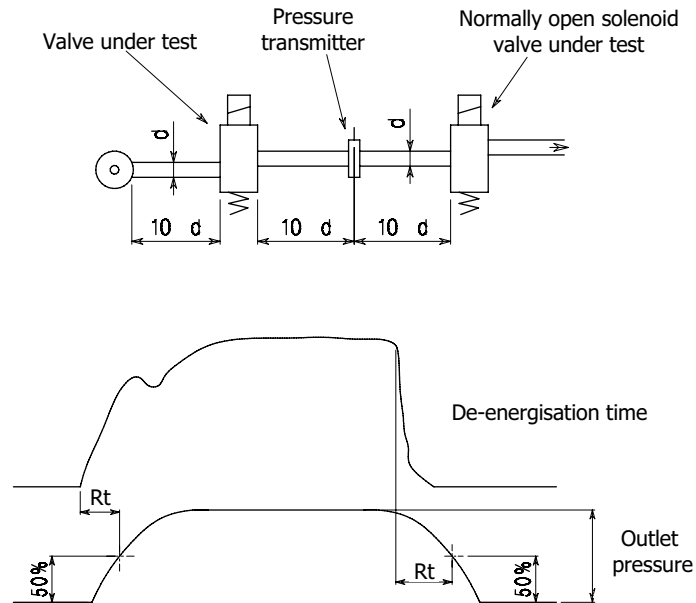

The response time depends from the type of valve, the nature of the medium, the pressure and the current (AC or DC), if these value are measured at the moment of electrical connection or disconnection.

Series	Tr (ms) Air P=6bar		Notes
	Opening	Closing	
2 and 3 ways direct acting NC	8	25	with liquids +50% ÷ +150% depending on the viscosity
2 and 3 ways direct acting NO	25	8	
Servoassisted NC G3/8" - G1/2" G3/4" - G1"	30	50	
	50	70	
Servoassisted NO G3/8" - G1/2" G3/4" - G1"	50	30	
	70	50	
Servoassisted G1"1/4 - G1"1/2 - G2" G2"1/2 - G3"	Adjustable time		

## **1.11 P.E.D. Directive (2014/68/UE)**

### **P.E.D. DECLARATION OF CONFORMITY**

**ACL S.r.l.**  
**Via Giovanni Falcone, 6**  
**20873 Cavenago di Brianza (MI)**

Declares that the solenoid valves listed in the present catalogue are in conformity with the following EU directive

#### **2014/68/UE (Pressure Equipment Directive)**

We also declare that they are not allowed to carry the CE mark in conformity to the article 3, paragraph 3.

#### **Remark:**

In case that on our goods you will find the CE sticker, means that the product meets the EC 89/336, EC 92/31, EC 93/68, EC 72/23. Limitedly to the rules apply by EN 55014, EN 61000-3-2, EN 61000-3-3, EN 60335-1 (CEI 61-150 volume N 2616E).

## 1.12 Operating instruction and installation

### 1. PRECAUTIONS DURING THE HYDRAULIC CONNECTION

Check that the valve series meets the application. Don't exceed the specification shown on the valve label.

Check that the fluid is in the same direction as the arrow stamped on the valve body and that the pipes are compatible with the flow rate of the valve.

Check that the pipes are clean and, if possible, fit a filter before the valve.

When connecting the valve, make sure that no foreign matter and sealing materials such as tape and jointing paste get inside the valve, as this could obstruct the internal pilot holes. (pilot operated valves)

When making connections using a wrench, apply force only the body of the valve. Avoid the coil area.

The solenoid valve can work in any position but to avoid the eventual precipitation of impurities inside the guide tube it's recommended that the coil is positioned above a horizontal pipe run.

When connecting with flexible tubes, it's recommended to use the provided fixing holes. (types with 1/8" and 1/4" threads)

### 2. PRECAUTIONS DURING THE ELECTRICAL CONNECTION

Check if the electrical data on the coil are compatible with the electrical supply.

The direct current valves don't require a fixed polarity with the exception of bi-stable valves.

To help heat dissipation of the coil, put the valve in a ventilated environment away from any other heat source.

It's possible that the coil working temperature could, in conjunction with ambient and fluid temperatures, cause scorching.

It's recommended an appropriate protection of the coil from water and humidity.

The coil fixing nut should not be over tightened. Don't exceed a torque more than 1.5Nm

### 3. MAINTENANCE

Coils can be changed without removing the valve from the system.

Spare parts are available for all wearing valve components.

When replacing the guide tube do not exceed the following tightening torque :

Normally Open valves	Normally Closed valves
16mm wrench=10Nm	11mm wrench=5Nm
22mm wrench=20Nm	16mm wrench=15Nm
	22mm wrench=50Nm

Before removing the valve, check that the power supply has been switched off and that no pressure is present in the pipeline.

If the valve needs cleaning, pay special attention to the seat area to avoid any damage.

The plunger must move freely inside the guide tube. If this isn't achievable due to incrustations, scale deposits or worn surfaces, then replacement parts must be fitted.

Seals must be replaced if swollen or damaged with incisions etc.

The diaphragm pilot holes must not be blocked to guarantee the correct operation of servo-assisted valves. Check that both holes are clear. Check also that the diaphragm has not hardened, swollen or it shows wear in the seat/seal area. Replace if necessary

### 4. GENERAL PRECAUTIONS

When the solenoid valve is used on machines or equipment with high mechanical stress (for example, vibrating stress), contact the manufacturer or verify life and functionality testes with appropriate tests.

## 1.13 Model identification

Solenoid valves are identified as follow:

### 1.13.1 DIRECT ACTING

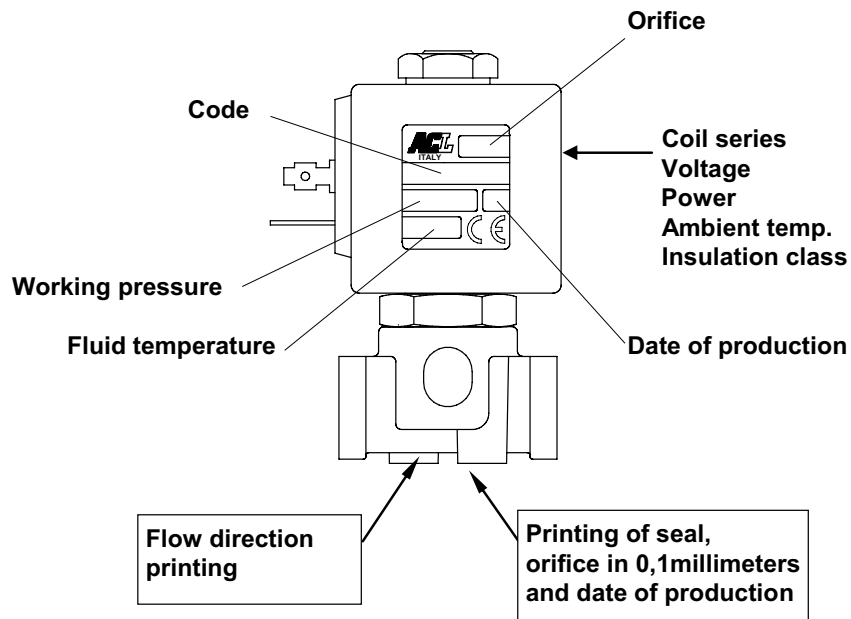

### 1.13.2 SERVO-ASSISTED

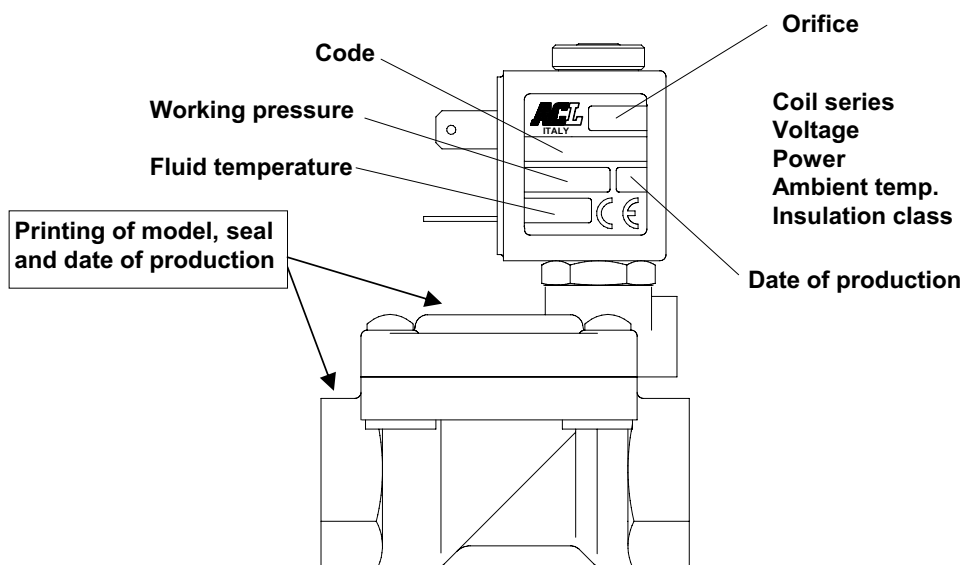



**DESCRIPTION**

Solenoid valve 2 way normally closed  
direct acting poppet type

**CONSTRUCTION**

Body	Brass
Armature tube	Brass
Plunger and core	Stainless steel
Springs	Stainless steel
Seal material	NBR - FPM - EPDM



**2**

**FEATURES**

Maximum allowable pressure 50bar\*  
 Maximum fluid viscosity 25cSt (mm<sup>2</sup>/s)  
 Ambient temperature: with class F coil -10°C +55°C  
 with class H coil -10°C +80°C  
 Universal mounting position

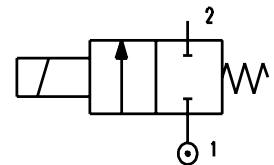

- OPTIONS:** Stainless steel armature tube  
 Electroless nickel plating  
 Series 7 explosion proof coil according to ATEX - EExmII  
 Manual override  
 Version for use with oxygen  
 c us certified coils

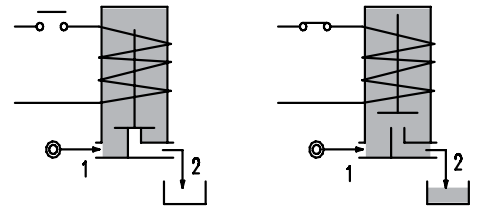

CODE ① ②	Connection G ISO 228	Orifice mm	Kv m <sup>3</sup> /h	Differential pressure bar			Nominal power			Coil		Seal ①	Temp. range °C
				Min	Max		AC Inrush	VA Holding	DC Watt	Series	Width		
					AC	DC							
E105A...12///...	1/8"	1.2	0.04	0	25	25	12	8	6.5	3	22	NBR=B	-10 +90
E105A...15///...		1.5	0.06	0	16	16							
E105A...20///...		2	0.09	0	12	10							
E105A...25///...		2.5	0.14	0	8	5.5							
E105A...31///...		3.1	0.19	0	5	2							
E105A...40///...		4	0.35	0	4	1.5							
E105A...20///...	1/8"	2	0.09	0	25	15	15	11	5	4	30	FPM=V	-10 +140
E105A...25///...		2.5	0.14	0	16	8							
E105A...31///...		3.1	0.19	0	8	4							
E105A...40///...		4	0.35	0	5	2.5							

① Seal Example: E105AB20///30B NBR seal  
 ② Coil Coil 24V 50/60Hz

\* REMARK: The maximum allowable pressure PS for steam is 2,5bar

COILS	Alternating Current 50/60Hz Volt							Direct Current Volt			Electrical connection	Connectors
	12	24	48	110	220 230	240	380	12	24	48		
Series 3 Width 22 Code ②	30A	30B	30C	30D	30E	30F	30G	300	301	302	DIN 46244	PG9 code 10348000
Series 4 Width 30 Code ②	40A	40B	40C	40D	40E	40F	40G	400	401	402	DIN 43650A	PG9 code 10349000

**DESCRIPTION**  
 Class F insulation  
 Voltage tolerance  
 AC +15% -10%  
 DC ± 10%  
 Protection class  
 IP65 with connector fitted  
 IP00 without connector  
 Continuous service  
 ED100%

**OPTIONS**  
 Class H insulation  
 Cable attached  
 Special coil voltage  
 Special coil powers  
 us certified coils

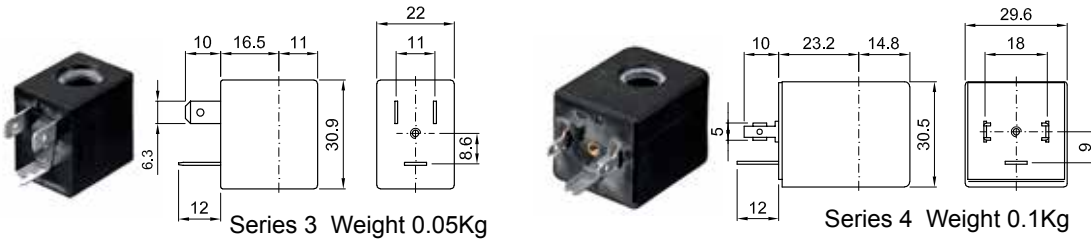

Series 3 Weight 0.05Kg

Series 4 Weight 0.1Kg

### SPARE PARTS LIST

1. Coil fixing nut
2. Coil
3. Plunger
4. Armature tube with core

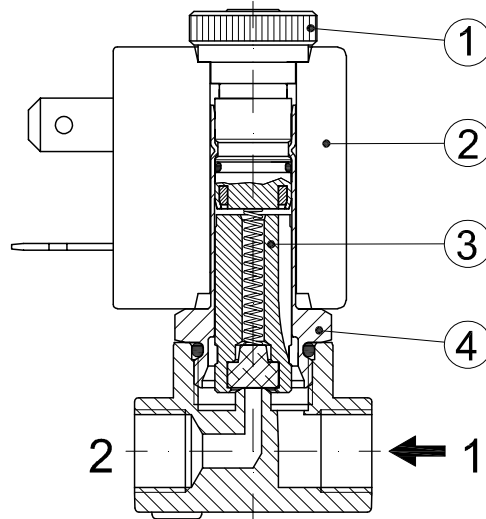

### MANUAL OVERRIDE

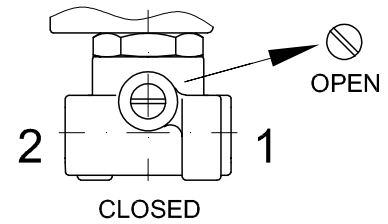

### OVERALL DIMENSION

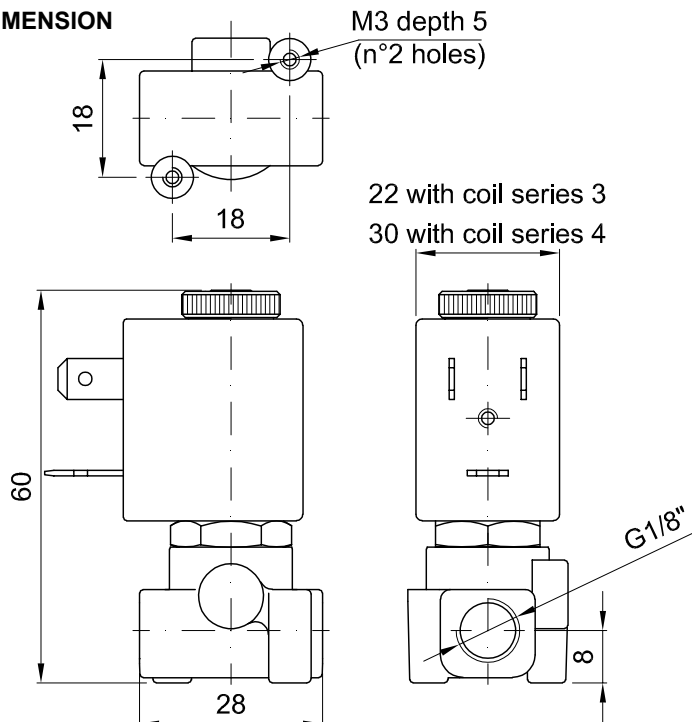

Weight with coil series 3=0.13Kg  
 Weight with coil series 4=0.18Kg

**DESCRIPTION**

Solenoid valve 2 way normally closed  
direct acting poppet type

**CONSTRUCTION**

Body	Brass
Armature tube	Brass
Plunger and core	Stainless steel
Springs	Stainless steel
Seal material	FPM



**2**

**FEATURES**

Maximum allowable pressure 50bar\*  
 Maximum fluid viscosity 25cSt (mm<sup>2</sup>/s)  
 Ambient temperature: with class F coil -10°C +55°C  
 with class H coil -10°C +80°C  
 Universal mounting position

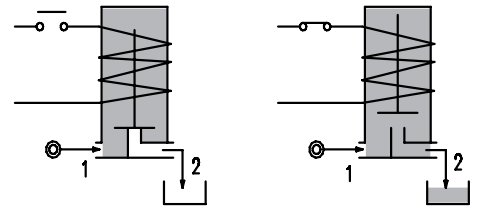
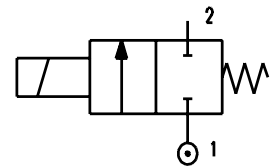

CODE ②	Connection G ISO 228	Orifice mm	Kv m <sup>3</sup> /h	Differential pressure bar			Nominal power			Coil		Seal	Temp. range °C
				Min	Max		AC Inrush	VA Holding	DC Watt	Series	Width		
					AC	DC							
W105AV15///...	1/8"	1.5	0.06	0	14	3	12	8	6.5	3	22	FPM=V	-10 +140

② Coil

\* REMARK: The maximum allowable pressure PS for steam is 2,5bar

COILS	Alternating Current 50/60Hz Volt							Direct Current Volt			Electrical connection	Connectors
	12	24	48	110	220 230	240	380	12	24	48		
Series 3 Width 22 Code ②	30A	30B	30C	30D	30E	30F	30G	300	301	302	DIN 46244	PG9 code 10348000

**DESCRIPTION**  
 Class F insulation  
 Voltage tolerance  
 AC +15% -10%  
 DC ± 10%  
 Protection class  
 IP65 with connector fitted  
 IP00 without connector  
 Continuous service ED100%

**OPTIONS**  
 Class H insulation  
 Cable attached  
 Special coil voltage  
 Special coil powers

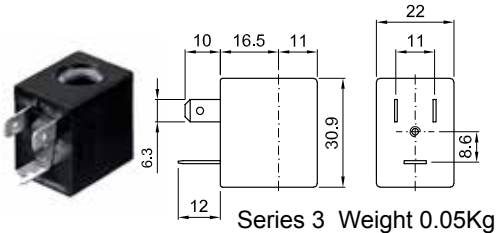

### SPARE PARTS LIST

1. Coil fixing nut
2. Coil
3. Valve

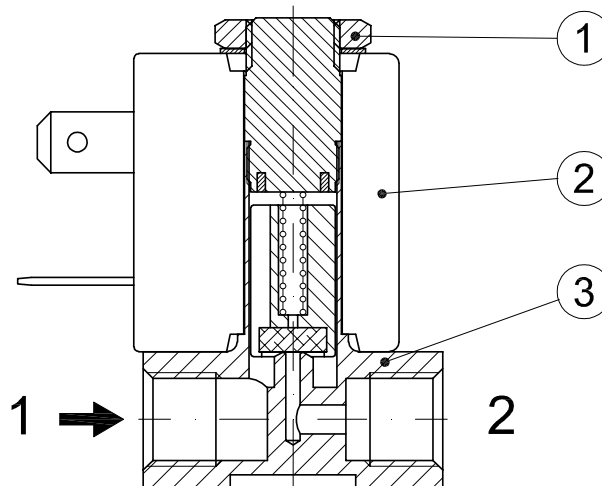

### OVERALL DIMENSION

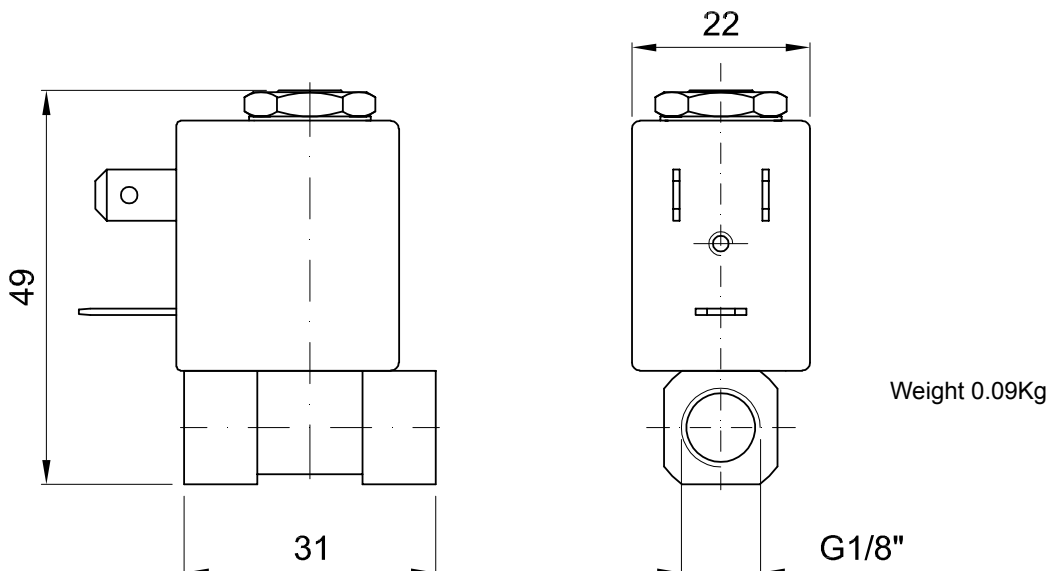

**DESCRIPTION**

Solenoid valve 2 way normally closed  
direct acting poppet type

**CONSTRUCTION**

Body	Brass
Armature tube	Stainless steel
Plunger and core	Stainless steel
Springs	Stainless steel
Seal material	NBR - FPM - EPDM - PTFE



2

**FEATURES**

Maximum allowable pressure 80bar\*  
 Maximum fluid viscosity 25cSt (mm<sup>2</sup>/s)  
 Ambient temperature: with class F coil -10°C +55°C  
 with class H coil -10°C +80°C  
 Universal mounting position

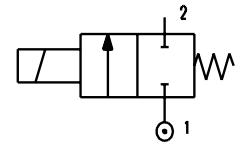

**OPTIONS:** Manual override  
 Electroless nickel plating  
 Stainless steel seat insert  
 Version for use with oxygen  
 c us certified coils

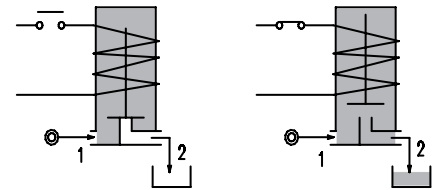

CODE ① ②	Connection G ISO 228	Orifice mm	Kv m <sup>3</sup> /h	Differential pressure bar			Nominal power			Coil		Seal ①	Temp. range °C							
				Min	Max		AC Inrush	VA Holding	DC Watt	Series	Width									
					AC	DC														
E106A...15///...	1/8"	1.5	0.07	0	30	26	20	15	10	2	30	NBR=B	-10 +90							
E106A...20///...		2	0.1	0	22	20														
E106A...25///...		2.5	0.15	0	16	14														
E106A...35///...		3.5	0.32	0	10	8														
E106B...15///...	1/4"	1.5	0.07	0	30	26								40	30	27	5	36	EPDM=E	-10 +140
E106B...20///...		2	0.1	0	22	20														
E106B...25///...		2.5	0.15	0	16	14														
E106B...35///...		3.5	0.32	0	10	8														
E106B...45///...		4.5	0.41	0	6.5	3.5														
E106B...52///...		5.2	0.47	0	4	1.8														
E106B...64///...	6.4	0.64	0	3	1															
E106A...15///...	1/8"	1.5	0.07	0	80	80													40	30
E106A...20///...		2	0.1	0	50	40														
E106A...25///...		2.5	0.15	0	35	33														
E106A...35///...		3.5	0.32	0	20	19														
E106B...15///...	1/4"	1.5	0.07	0	80	80	40	30	27	5	36	PTFE=W	-10 +180							
E106B...20///...		2	0.1	0	50	40														
E106B...25///...		2.5	0.15	0	35	33														
E106B...35///...		3.5	0.32	0	20	19														
E106B...45///...		4.5	0.41	0	14	13														
E106B...52///...		5.2	0.47	0	10	9														
E106B...64///...	6.4	0.64	0	5	4.5															

① Seal Example: E106BB20///20E NBR seal  
 ② Coil Coil 230V 50/60Hz

③ Maximum allowable leakage <0.2NI/h

\* REMARK: The maximum allowable pressure PS for steam is 6bar with PTFE seals and 2,5bar with EPDM seals

COILS	Alternating Current 50/60Hz Volt							Direct Current Volt			Electrical connection	Connectors
	12	24	48	110	220 230	240	380	12	24	48		
Series 2 Width 30 Code ②	20A	20B	20C	20D	20E	20F	20G	200	201	202	DIN 43650A	PG9 code 10349000
Series 5 Width 36 Code ②	52A	52B	52C	52D	52E	52F	52G	520	521	522	DIN 43650A	PG11 code 10349001

**DESCRIPTION**  
 Insulation class  
 Series 2 =F Series 5=H  
 Voltage tolerance  
 AC +15% -10%  
 DC ± 10%  
 Protection class  
 IP65 with connector fitted  
 IP00 without connector  
 Continuous service ED100%

**OPTIONS**  
 Class H insulation (series 2)  
 Cable attached  
 Special coil voltage  
 Special coil powers  
 CE certified coils

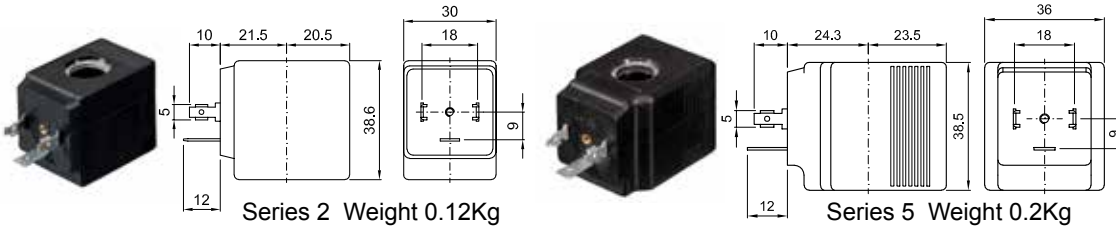

### SPARE PARTS LIST

1. Coil fixing nut
2. Coil
3. Plunger
4. Armature tube with core

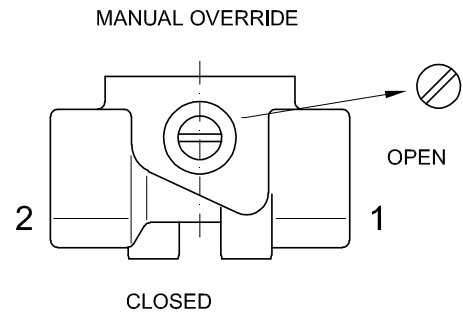
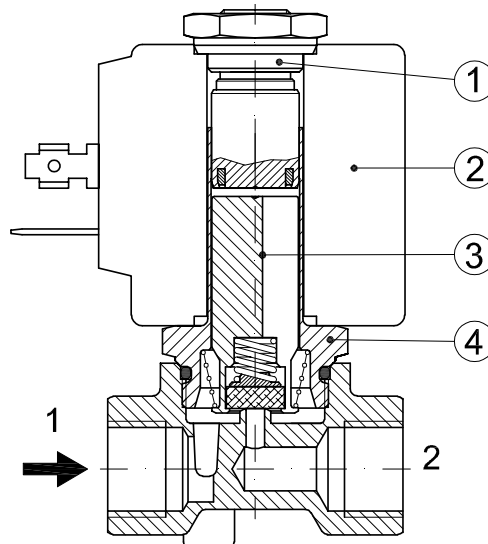

### OVERALL DIMENSION

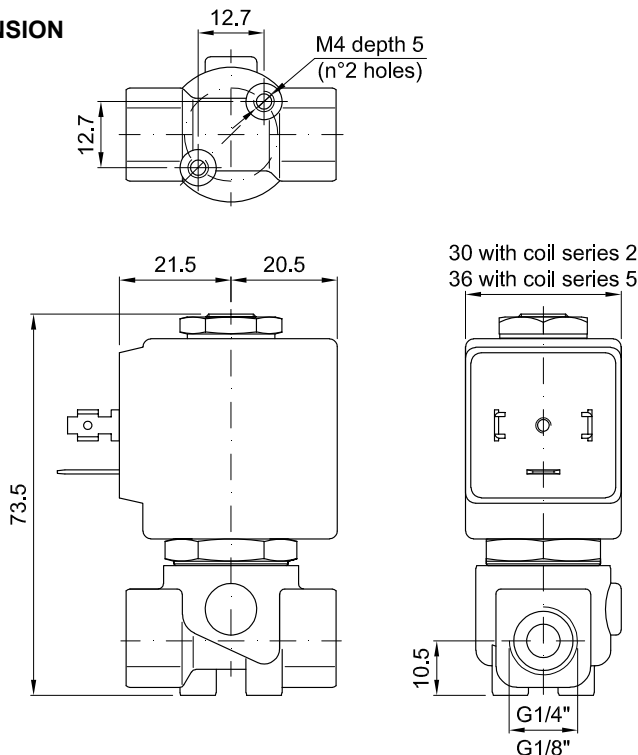

Weight with coil series 2=0.30Kg  
 Weight with coil series 5=0.38Kg

**DESCRIPTION**

Solenoid valve 2 way normally closed  
direct acting poppet type

**CONSTRUCTION**

Body	Brass
Armature tube	Stainless steel
Plunger and core	Stainless steel
Springs	Stainless steel
Seal material	NBR - FPM - EPDM - PTFE



**2**

**FEATURES**

Maximum allowable pressure 80bar\*  
 Maximum fluid viscosity 25cSt (mm<sup>2</sup>/s)  
 Ambient temperature: with class F coil -10°C +55°C  
 with class H coil -10°C +80°C  
 Universal mounting position

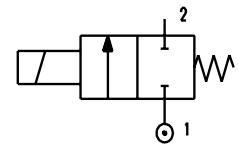

**OPTIONS:** Electroless nickel plating  
 Version for use with oxygen  
 c us certified coils

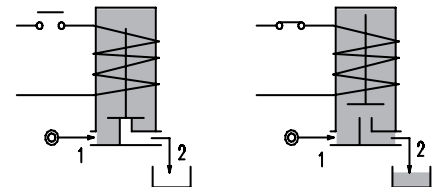

CODE ① ②	Connection G ISO 228	Orifice mm	Kv m <sup>3</sup> /h	Differential pressure bar			Nominal power			Coil		Seal ①	Temp. range °C
				Min	Max		AC Inrush	VA Holding	DC Watt	Series	Width		
					AC	DC							
E106C...30///...	3/8"	3	0.25	0	15	10	20	15	10	2	30	NBR=B	-10 +90
E106C...35///...		3.5	0.32	0	10	8							
E106C...40///...		4	0.36	0	8	5							
E106C...45///...		4.5	0.41	0	6.5	3.5							
E106C...52///...		5.2	0.47	0	4	1.8							
E106C...64///...		6.4	0.64	0	3	1							
E106D...30///...	1/2"	3	0.25	0	15	10	20	15	10	2	30	NBR=B	-10 +90
E106D...35///...		3.5	0.32	0	10	8							
E106D...40///...		4	0.36	0	8	5							
E106D...45///...		4.5	0.41	0	6.5	3.5							
E106D...52///...		5.2	0.47	0	4	1.8							
E106D...64///...		6.4	0.64	0	3	1							
E106C...30///...	3/8"	3	0.25	0	25	24	40	30	27	5	36	FPM=V	-10 +140
E106C...35///...		3.5	0.32	0	20	19							
E106C...40///...		4	0.36	0	16	15							
E106C...45///...		4.5	0.41	0	14	13							
E106C...52///...		5.2	0.47	0	10	9							
E106C...64///...		6.4	0.64	0	5	4.5							
E106D...30///...	1/2"	3	0.25	0	25	24	40	30	27	5	36	PTFE=W ③	-10 +180
E106D...35///...		3.5	0.32	0	20	19							
E106D...40///...		4	0.36	0	16	15							
E106D...45///...		4.5	0.41	0	14	13							
E106D...52///...		5.2	0.47	0	10	9							
E106D...64///...		6.4	0.64	0	5	4.5							

① Seal Example: E106CB20///20E NBR seal  
 ② Coil Coil 230V 50/60Hz

③ Maximum allowable leakage <0.2NI/h

\* REMARK: The maximum allowable pressure PS for steam is 6bar with PTFE seals and 2,5bar with EPDM seals

COILS	Alternating Current 50/60Hz Volt							Direct Current Volt			Electrical connection	Connectors
	12	24	48	110	220 230	240	380	12	24	48		
Series 2 Width 30 Code ②	20A	20B	20C	20D	20E	20F	20G	200	201	202	DIN 43650A	PG9 code 10349000
Series 5 Width 36 Code ②	52A	52B	52C	52D	52E	52F	52G	520	521	522	DIN 43650A	PG11 code 10349001

**DESCRIPTION**  
 Insulation class  
 Series 2 =F Series 5=H  
 Voltage tolerance  
 AC +15% -10%  
 DC ± 10%  
 Protection class  
 IP65 with connector fitted  
 IP00 without connector  
 Continuous service ED100%

**OPTIONS**  
 Class H insulation (series 2)  
 Cable attached  
 Special coil voltage  
 Special coil powers  
 cULus certified coils

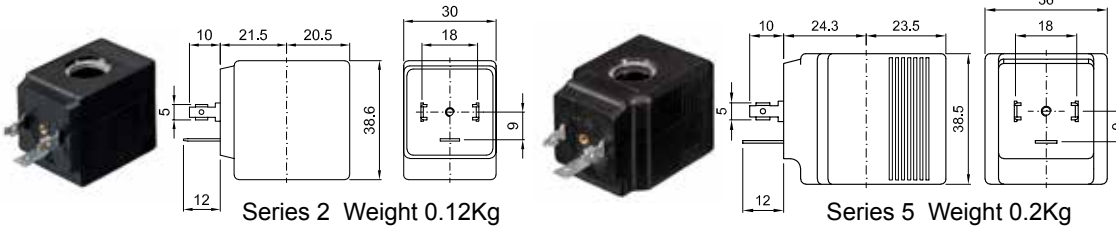

### SPARE PARTS LIST

1. Coil fixing nut
2. Coil
3. Plunger
4. Armature tube with core

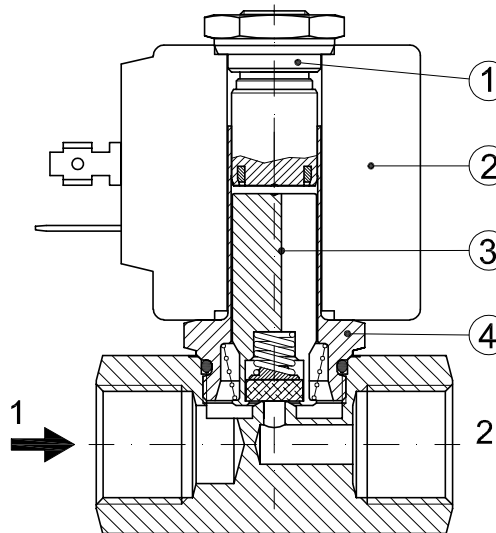

### OVERALL DIMENSION

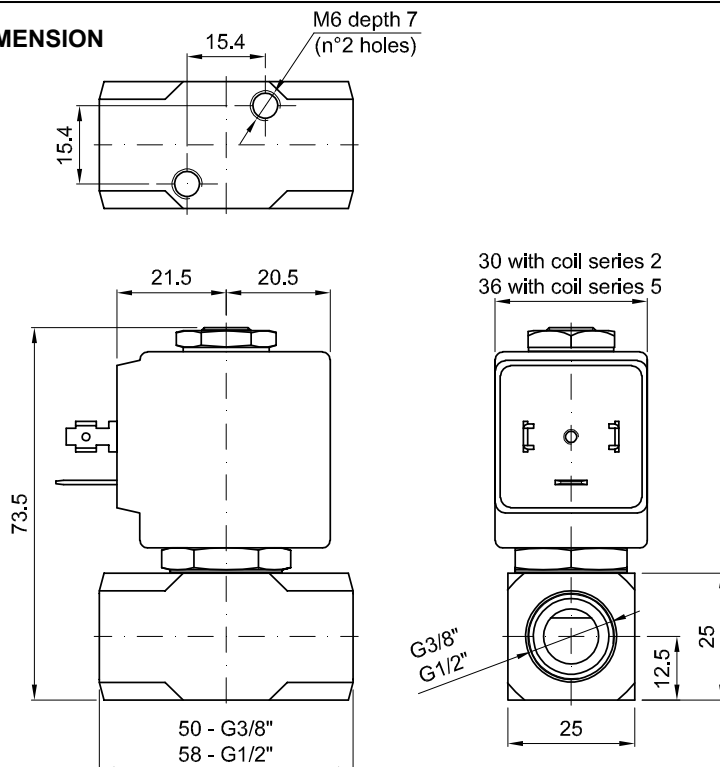

Weight with coil series 2=0.36Kg  
 Weight with coil series 5=0.44Kg



**DESCRIPTION**

Solenoid valve 2 way normally closed  
direct acting poppet type.

With explosion proof coil certified for hazardous area:

**Ex** II 2GD Ex d IIC T6 or T5 or T4 Gb  
Ex tb IIIC T80°C or T95°C or T130°C Db IP66  
Tamb -10°C ÷ +35°C(T6) or +50°C(T5) or +60°C(T4)

(other certifications e.g. Gost-r, Baseefa, CCOE etc. on request)



**VALVE CONSTRUCTION**

Body Brass  
Seal material FPM

**EXPLOSION PROOF COIL CONSTRUCTION**

Housing Red colour alloy  
Electrical connection 1/2" NPT

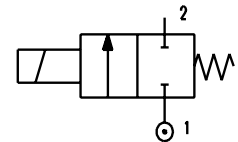

**FEATURES**

Maximum allowable pressure 80bar  
Maximum fluid viscosity 25cSt (mm<sup>2</sup>/s)  
Ambient temperature: -10°C ÷ +35°C(T6), +50°C(T5), +60°C(T4)  
Mounting position with vertical coil above

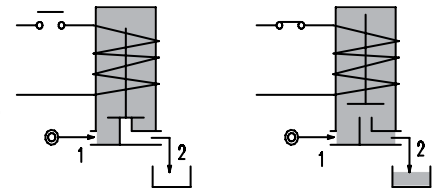

**OPTIONS:** Manual override  
Electroless nickel plating  
Stainless steel seat

**NOTE:** The solenoid valve is suitable only with media that are **NOT** potentially explosive

CODE ②	Connection G ISO 228	Orifice mm	Kv m <sup>3</sup> /h	Differential pressure bar			Nominal power		Coil series	Seal	Temp. range °C					
				Min	Max		AC Holding	DC								
					AC	DC										
A106AV15///...	1/8"	1.5	0.07	0	30	26	12 VA	8W	A6	FPM=V	-10 +140					
A106AV20///...		2	0.1	0	22	20										
A106AV25///...		2.5	0.15	0	16	14										
A106AV35///...		3.5	0.32	0	10	8										
A106BV15///...	1/4"	1.5	0.07	0	30	26						12 VA	8W	A6	FPM=V	-10 +140
A106BV20///...		2	0.1	0	22	20										
A106BV25///...		2.5	0.15	0	16	14										
A106BV35///...		3.5	0.32	0	10	8										
A106BV45///...		4.5	0.41	0	6.5	3.5										
A106BV52///...		5.2	0.47	0	4	1.8										
A106BV64///...		6.4	0.64	0	3	1										

② Coil

COILS	Alternating Current 50/60Hz Volt				Direct Current Volt			Electrical connection
	24	48	110	220 230	12	24	48	
Series A6 Code ②	A6B	A6C	A6D	A6E	A60	A61	A62	1/2" NPT

**DESCRIPTION**  
 Voltage tolerance  
 AC +15% -10%  
 DC ± 10%  
 Protection class IP66  
 Continuous service ED100%

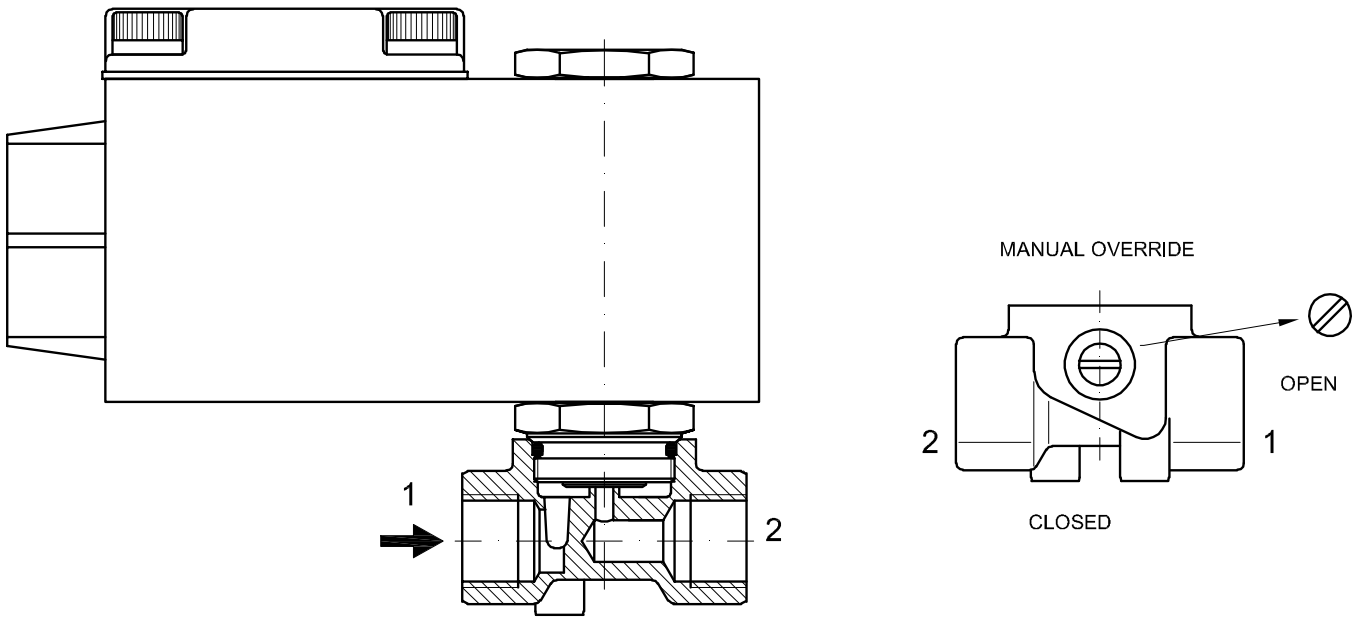

### OVERALL DIMENSION

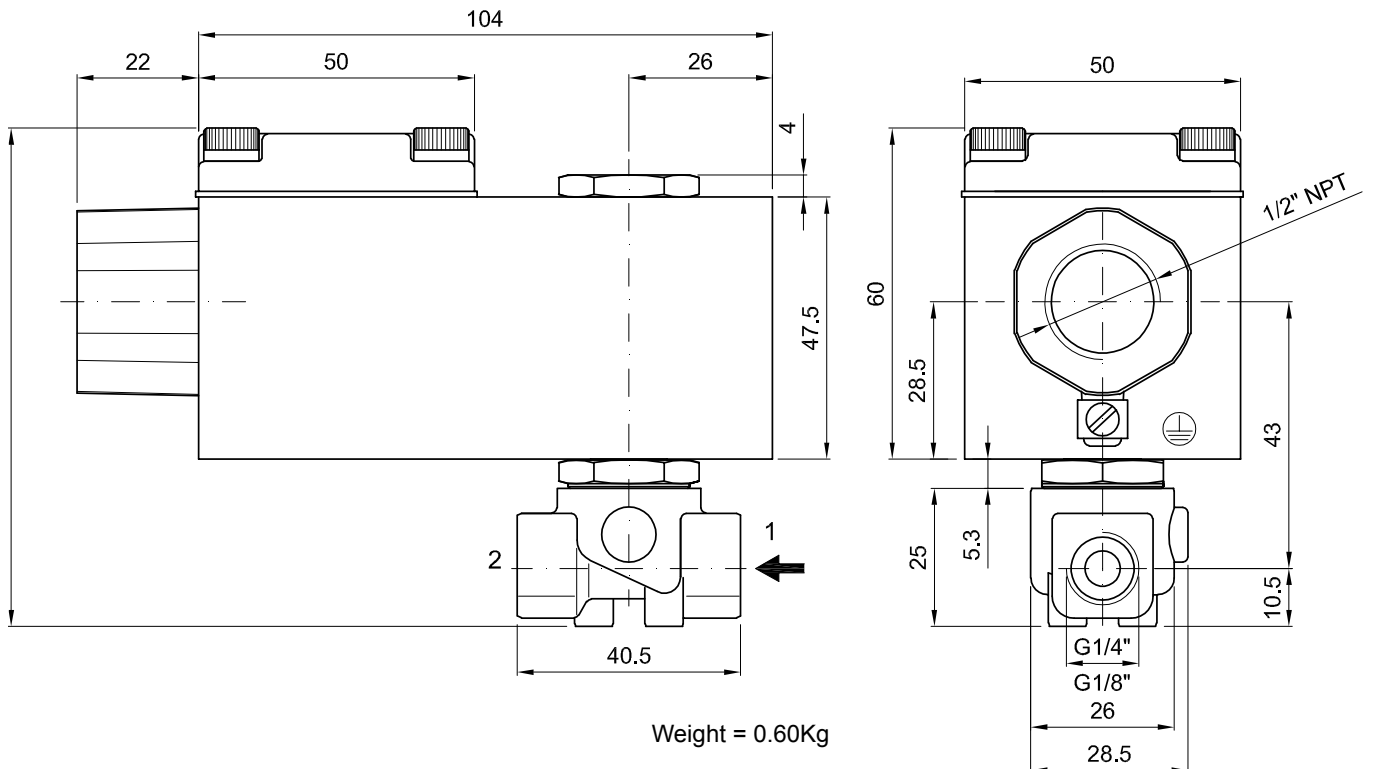

**DESCRIPTION**

Solenoid valve 2 way normally closed  
direct acting poppet type.

With explosion proof coil certified for hazardous area:

**Ex** II 2GD Ex d IIC T6 or T5 or T4 Gb  
Ex tb IIC T80°C or T95°C or T130°C Db IP66  
Tamb -10°C ÷ +35°C(T6) or +50°C(T5) or +60°C(T4)

(other certifications e.g. Gost-r, Baseefa, CCOE etc. on request)



**2**

**VALVE CONSTRUCTION**

Body Brass  
Seal material FPM

**EXPLOSION PROOF COIL CONSTRUCTION**

Housing Red colour alloy  
Electrical connection 1/2" NPT

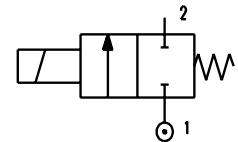

**FEATURES**

Maximum allowable pressure 80bar  
Maximum fluid viscosity 25cSt (mm<sup>2</sup>/s)  
Ambient temperature: -10°C ÷ +35°C(T6), +50°C(T5), +60°C(T4)  
Mounting position with vertical coil above

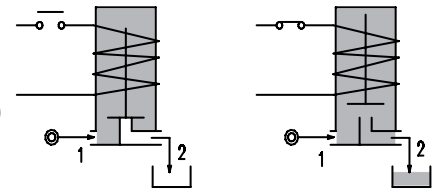

**OPTIONS:** Electroless nickel plating  
Stainless steel seat

**NOTE:** The solenoid valve is suitable only with media that are **NOT** potentially explosive

CODE ②	Connection G ISO 228	Orifice mm	Kv m <sup>3</sup> /h	Differential pressure bar			Nominal power		Coil series	Seal	Temp. range °C
				Min	Max		AC Holding	DC			
					AC	DC					
A106CV30///...	3/8"	3	0.25	0	15	10	12 VA	8W	A6	FPM=V	-10 +140
A106CV35///...		3.5	0.32	0	10	8					
A106CV40///...		4	0.36	0	8	5					
A106CV45///...		4.5	0.41	0	6.5	3.5					
A106CV52///...		5.2	0.47	0	4	1.8					
A106CV64///...		6.4	0.64	0	3	1					
A106DV30///...	1/2"	3	0.25	0	15	10	12 VA	8W	A6	FPM=V	-10 +140
A106DV35///...		3.5	0.32	0	10	8					
A106DV40///...		4	0.36	0	8	5					
A106DV45///...		4.5	0.41	0	6.5	3.5					
A106DV52///...		5.2	0.47	0	4	1.8					
A106DV64///...		6.4	0.64	0	3	1					

② Coil

COILS	Alternating Current 50/60Hz Volt				Direct Current Volt			Electrical connection
	24	48	110	220 230	12	24	48	
Series A6 Code ②	A6B	A6C	A6D	A6E	A60	A61	A62	1/2" NPT

**DESCRIPTION**  
 Voltage tolerance  
 AC +15% -10%  
 DC ± 10%  
 Protection class IP66  
 Continuous service ED100%

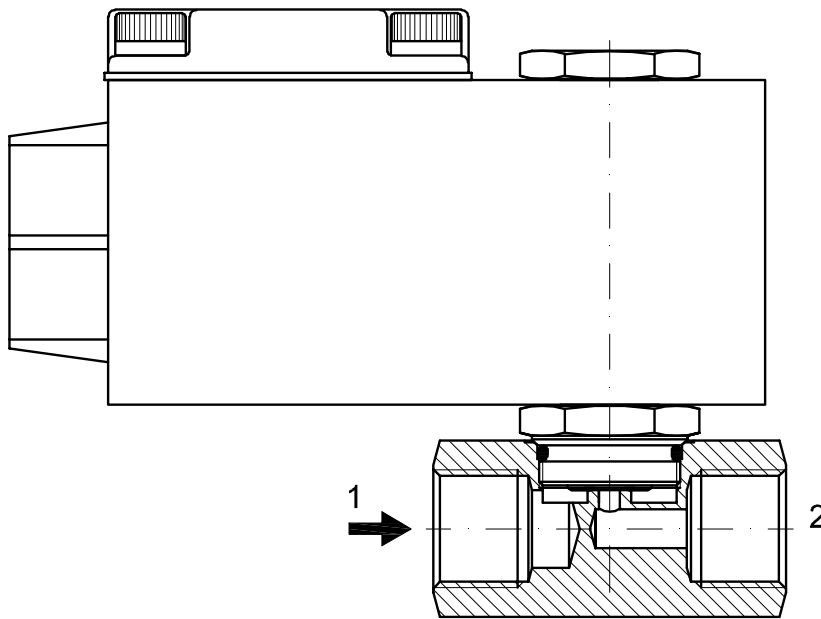

### OVERALL DIMENSION

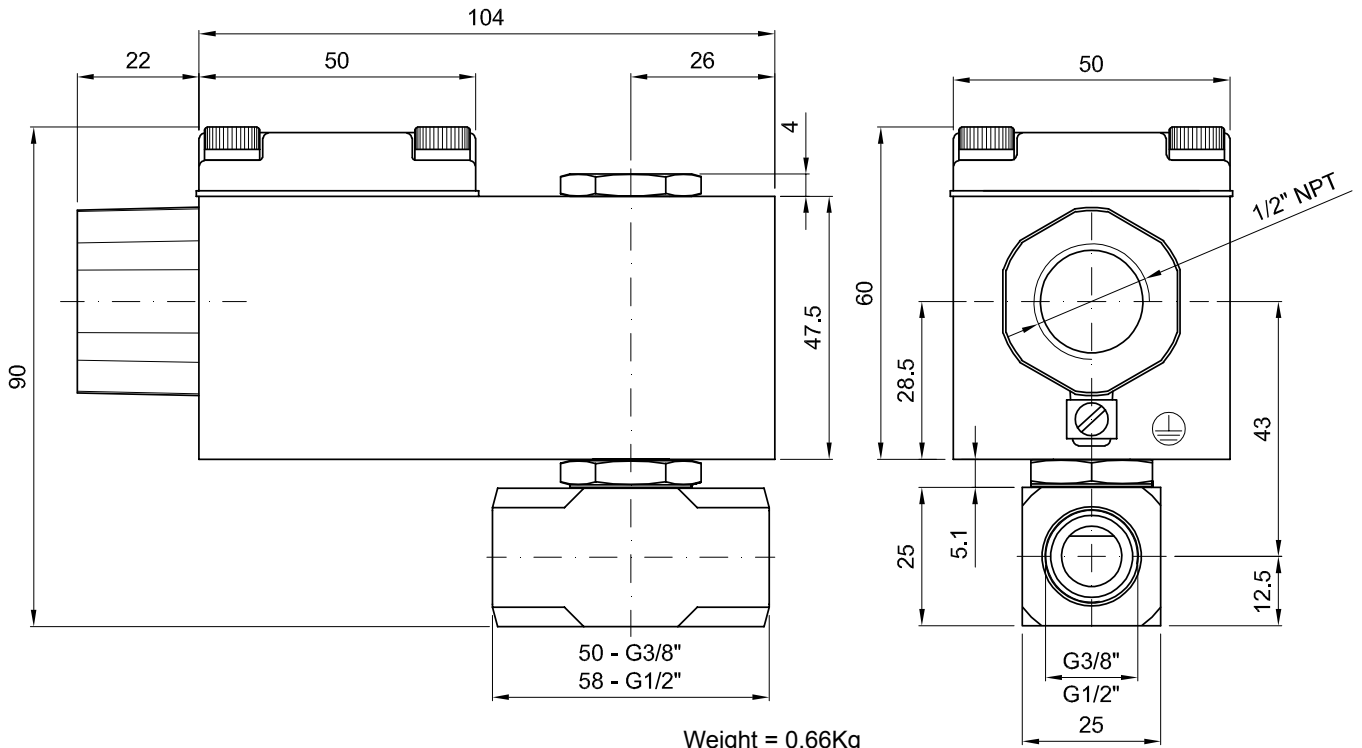

**DESCRIPTION**

Drain valve

**CONSTRUCTION**

Solenoid valve series 106 with:

- Filter ball valve in chromium plated brass and stainless steel strainer, NBR seal  
Connection : inlet G1/2", outlet G3/8" or G1/2"
- Timer ACL mod.11303000
- Connector DIN 43650A code 1034900A



**2**

**FEATURES**

Maximum allowable pressure 80bar

Maximum fluid viscosity 25cSt (mm<sup>2</sup>/s)

Ambient temperature: with class F coil -10°C +55°C  
with class H coil -10°C +80°C

Protection class IP65

- OPTIONS:** Electroless nickel plating on the valve body  
Overmoulded DIN cable connector  
c us certified coils

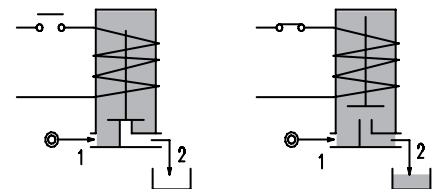
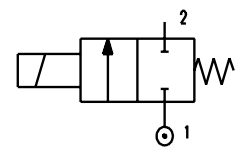

CODE ① ②	Connection G ISO 228	Orifice mm	Kv m <sup>3</sup> /h	Differential pressure bar			Nominal power			Coil		Seal ①	Temp. range °C
				Min	Max		AC Inrush	VA Holding	DC Watt	Series	Width		
					AC	DC							
S106BV30///...	1/4"	3	0.18	0	14	6	20	15	10	2	30	FPM=V	-10 +140
S106BV40///...		4	0.26	0	7	3							
S106C...30///...	3/8"	3	0.25	0	15	10	20	15	10	2	30	NBR=B	-10 +90
S106C...35///...		3.5	0.32	0	10	8							
S106C...40///...		4	0.36	0	8	5							
S106C...45///...		4.5	0.41	0	6.5	3.5							
S106D...30///...	1/2"	3	0.25	0	15	10	40	30	27	5	36	NBR=B	-10 +90
S106D...35///...		3.5	0.32	0	10	8							
S106D...40///...		4	0.36	0	8	5							
S106D...45///...		4.5	0.41	0	6.5	3.5							
S106C...30///...	3/8"	3	0.25	0	25	24	40	30	27	5	36	NBR=B	-10 +90
S106C...35///...		3.5	0.32	0	20	19							
S106C...40///...		4	0.36	0	16	15							
S106C...45///...		4.5	0.41	0	14	13							
S106D...30///...	1/2"	3	0.25	0	25	24	40	30	27	5	36	NBR=B	-10 +90
S106D...35///...		3.5	0.32	0	20	19							
S106D...40///...		4	0.36	0	16	15							
S106D...45///...		4.5	0.41	0	14	13							

① Seal

② Coil

Example: S106CB30///20E NBR seal

Coil 230V 50/60Hz

COILS	Alternating Current 50/60Hz Volt							Direct Current Volt			Electrical connection	Connectors
	12	24	48	110	220 230	240	380	12	24	48		
Series 2 Width 30 Code ②	20A	20B	20C	20D	20E	20F	20G	200	201	202	DIN 43650A	PG9 code 10349000
Series 5 Width 36 Code ②	52A	52B	52C	52D	52E	52F	52G	520	521	522	DIN 43650A	PG11 code 10349001

**DESCRIPTION**  
 Insulation class  
 Series 2 =F Series 5=H  
 Voltage tolerance  
 AC +15% -10%  
 DC ± 10%  
 Protection class  
 IP65 with connector fitted  
 IP00 without connector  
 Continuous service ED100%

**OPTIONS**  
 Class H insulation (series 2)  
 Cable attached  
 Special coil voltage  
 Special coil powers  
 cULus certified coils

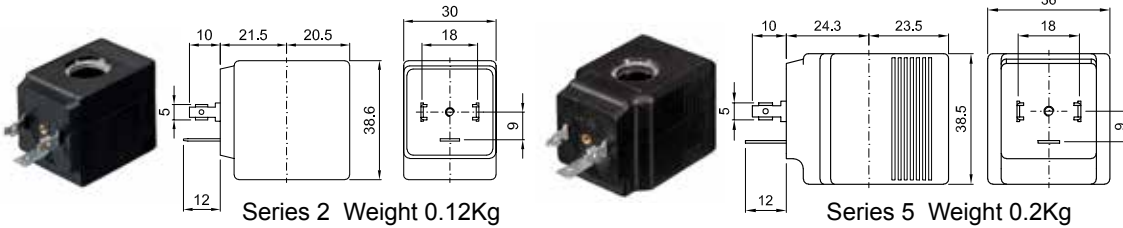

## OVERALL DIMENSION

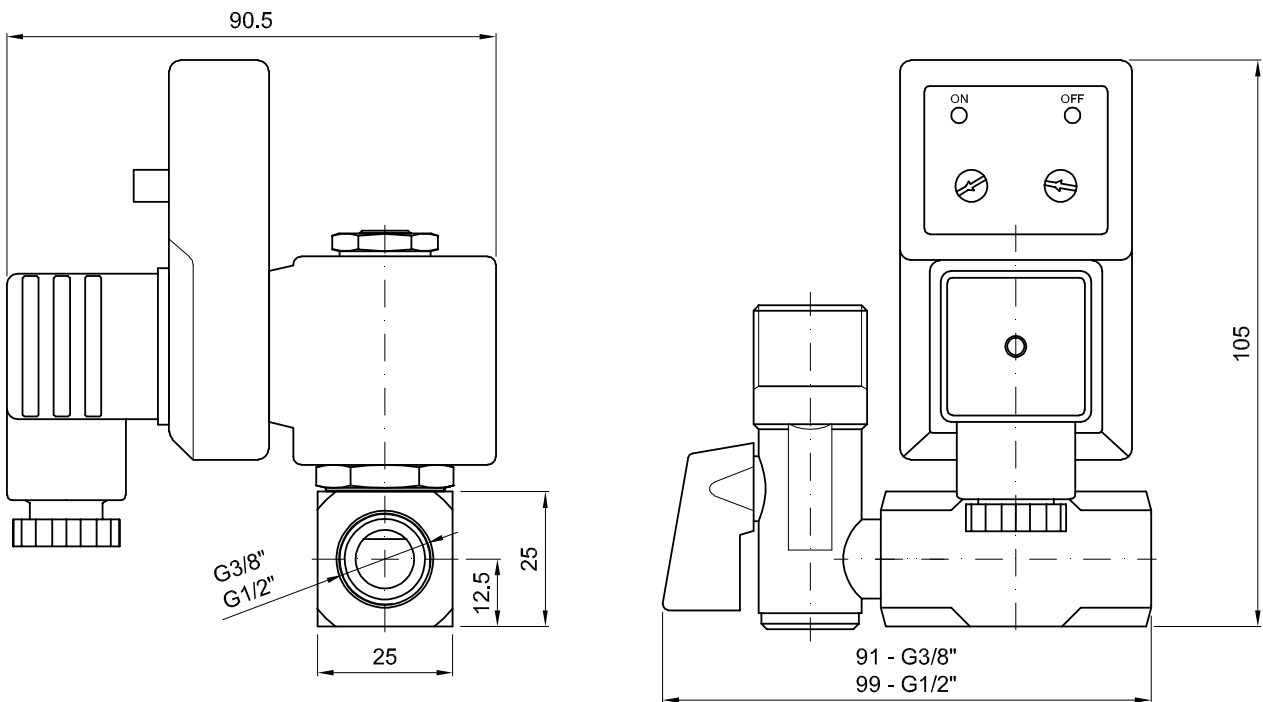

Weight with coil series 2=0.52Kg  
 Weight with coil series 5=0.60Kg

**DESCRIPTION**

Solenoid valve 2 way normally closed  
direct acting poppet type

**CONSTRUCTION**

Body	Brass
Armature tube	Stainless steel
Plunger and core	Stainless steel
Springs	Stainless steel
Seal material	FPM



**2**

**FEATURES**

Maximum allowable pressure 50bar\*  
 Maximum fluid viscosity 25cSt (mm<sup>2</sup>/s)  
 Ambient temperature: with class F coil -10°C +55°C  
 with class H coil -10°C +80°C  
 Universal mounting position

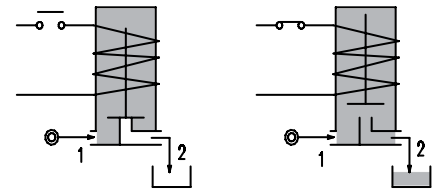
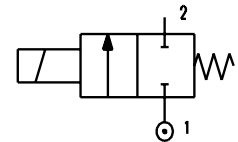

CODE ②	Connection G ISO 228	Orifice mm	Kv m <sup>3</sup> /h	Differential pressure bar			Nominal power			Coil		Seal	Temp. range °C
				Min	Max		AC Inrush	VA Holding	DC Watt	Series	Width		
					AC	DC							
W106BV30///...	1/8"	3	0.18	0	14	6	20	15	10	2	30	FPM=V	-10 +140
W106BV40///...		4	0.26	0	7	3							

② Coil

\* REMARK: The maximum allowable pressure PS for steam is 2,5bar

COILS	Alternating Current 50/60Hz Volt							Direct Current Volt			Electrical connection	Connectors
	12	24	48	110	220 230	240	380	12	24	48		
Series 2 Width 30 Code ②	20A	20B	20C	20D	20E	20F	20G	200	201	202	DIN 43650A	PG9 code 10349000

**DESCRIPTION**  
 Class F insulation  
 Voltage tolerance  
 AC +15% -10%  
 DC ± 10%  
 Protection class  
 IP65 with connector fitted  
 IP00 without connector  
 Continuous service ED100%

**OPTIONS**  
 Class H insulation  
 Cable attached  
 Special coil voltage  
 Special coil powers

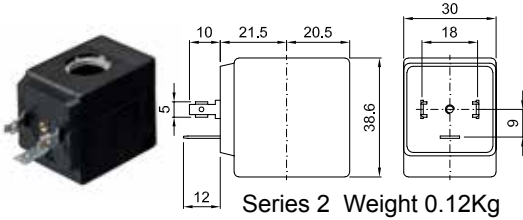

### SPARE PARTS LIST

1. Coil fixing nut
2. Coil
3. Valve

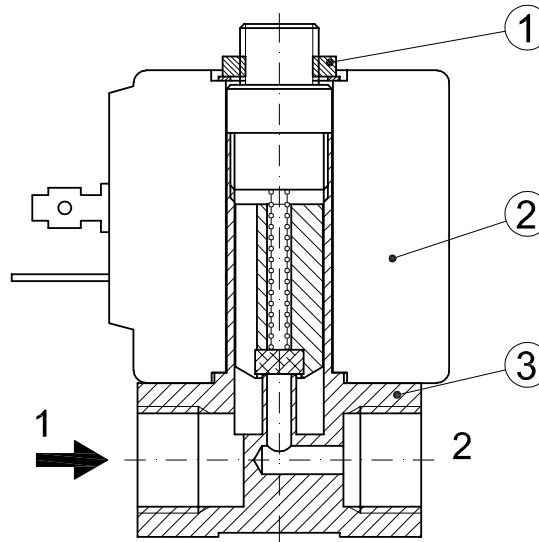

### OVERALL DIMENSION

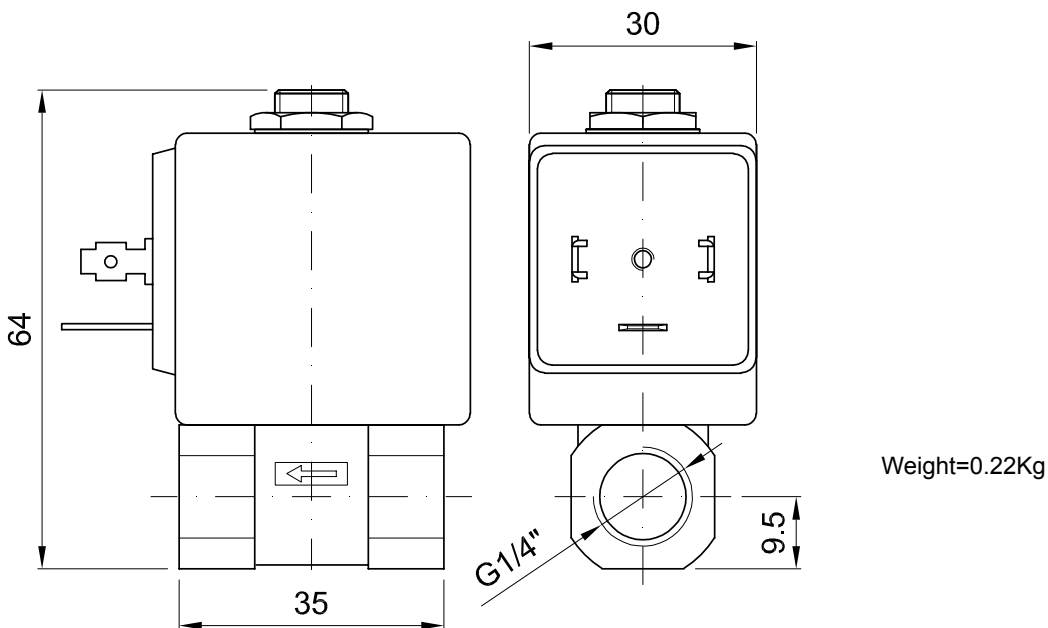



**DESCRIPTION**

Solenoid valve 2 way normally closed  
direct acting poppet type

**CONSTRUCTION**

Body	Brass
Armature tube	Stainless steel
Plunger and core	Stainless steel
Springs	Stainless steel
Seal material	NBR - FPM - EPDM

**FEATURES**

Maximum allowable pressure 5bar  
 Maximum fluid viscosity 25cSt (mm<sup>2</sup>/s)  
 Ambient temperature: with class F coil -10°C +55°C  
 with class H coil -10°C +80°C  
 Universal mounting position

**OPTIONS:** Electroless nickel plating  
 Version for use with oxygen  
 c us certified coils



**2**

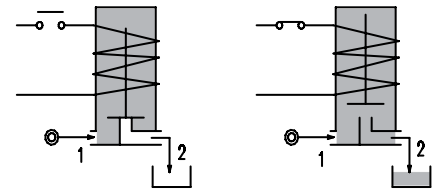
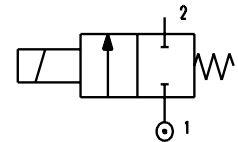

CODE ① ②	Connection G ISO 228	Orifice mm	Kv m <sup>3</sup> /h	Differential pressure bar			Nominal power			Coil		Seal ①	Temp. range °C
				Min	Max AC DC		AC Inrush	VA Holding	DC Watt	Series	Width		
E109C...12///...	3/8"	12	2	0	0.5	0.06	20	15	10	2	30	NBR=B	-10 +90
E109D...12///...	1/2"	12	2.2	0	0.5	0.06							
E109E...18///...	3/4"	18	4.5	0	0.14	--	20	15	--	5	36	EPDM=E	-10 +140
E109C...12///...	3/8"	12	2	0	0.8	0.4							
E109D...12///...	1/2"	12	2.2	0	0.8	0.4	40	30	27	5	36	FPM=V	-10 +140
E109E...18///...	3/4"	18	4.5	0	0.2	0.12							

① Seal Example: E109EV18///52B FPM seal  
 ② Coil Coil 24V 50/60Hz

COILS	Alternating Current 50/60Hz Volt							Direct Current Volt			Electrical connection	Connectors
	12	24	48	110	220 230	240	380	12	24	48		
Series 2 Width 30 Code ②	20A	20B	20C	20D	20E	20F	20G	200	201	202	DIN 43650A	PG9 code 10349000
Series 5 Width 36 Code ②	52A	52B	52C	52D	52E	52F	52G	520	521	522	DIN 43650A	PG11 code 10349001

**DESCRIPTION**  
 Insulation class  
 Series 2 =F Series 5=H  
 Voltage tolerance  
 AC +15% -10%  
 DC ± 10%  
 Protection class  
 IP65 with connector fitted  
 IP00 without connector  
 Continuous service ED100%

**OPTIONS**  
 Class H insulation (series 2)  
 Cable attached  
 Special coil voltage  
 Special coil powers  
 US certified coils

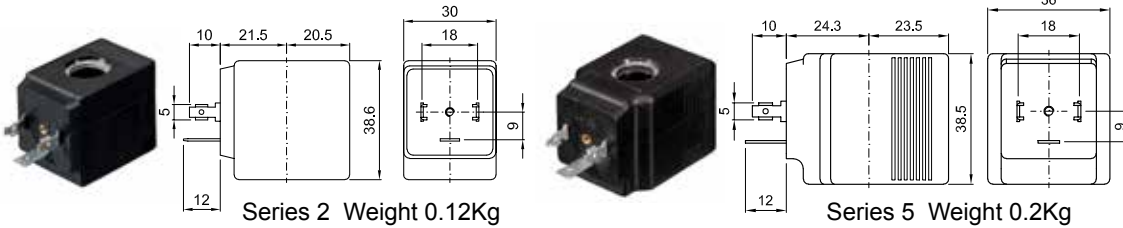

### SPARE PARTS LIST

1. Coil fixing nut
2. Coil
3. Plunger
4. Armature tube with core

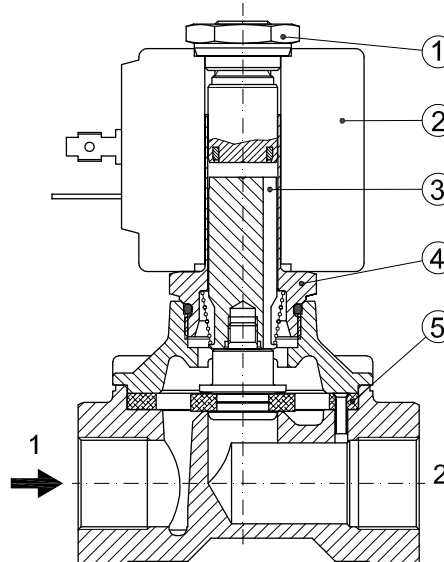

### OVERALL DIMENSION

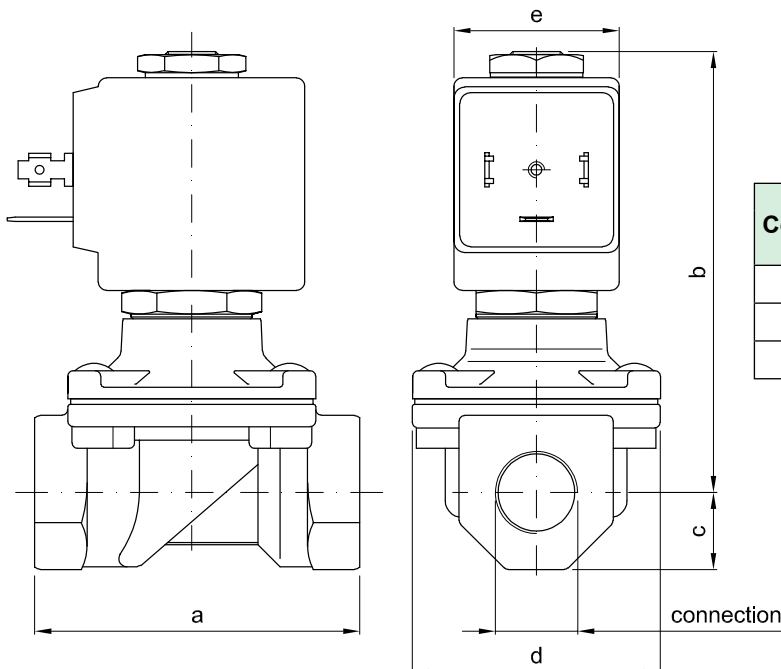

Connection	a	b	c	d	e		Weight kg	
					with series 2	with series 5	series 2	series 5
G3/8"	60	83	14	45	30	36	0.50	0.58
G1/2"	60	83	14	45	30	36	0.45	0.53
G3/4"	75	90	18	55	30	36	0.75	0.83

**DESCRIPTION**

Solenoid valve 2 way normally closed  
direct acting poppet type

**CONSTRUCTION**

Body	Stainless steel
Armature tube	Stainless steel
Plunger and core	Stainless steel
Springs	Stainless steel
Seal material	NBR - FPM - EPDM - PTFE



**2**

**FEATURES**

Maximum allowable pressure 100bar\*  
 Maximum fluid viscosity 25cSt (mm<sup>2</sup>/s)  
 Ambient temperature: with class F coil -10°C +55°C  
 with class H coil -10°C +80°C  
 Universal mounting position

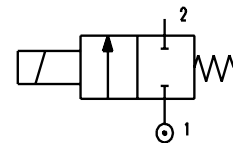

**OPTIONS:** Silver shading ring  
 Version for use with oxygen  
 c us certified coils

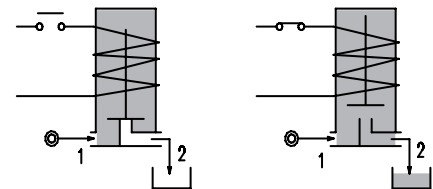

CODE ① ②	Connection G ISO 228	Orifice mm	Kv m <sup>3</sup> /h	Differential pressure bar			Nominal power			Coil		Seal ①	Temp. range °C							
				Min	Max		AC Inrush	VA Holding	DC Watt	Series	Width									
					AC	DC														
E110B...20///...	1/4"	2	0.1	0	22	20	20	15	10	2	30	NBR=B	-10 +90							
E110B...25///...		2.5	0.15	0	16	14														
E110B...35///...		3.5	0.32	0	10	8														
E110B...45///...		4.5	0.41	0	6.5	3.5														
E110B...52///...		5.2	0.47	0	4	1.8														
E110C...20///...	3/8"	2	0.1	0	22	20														
E110C...35///...		3.5	0.32	0	10	8														
E110C...52///...		5.2	0.47	0	4	1.8														
E110C...64///...		6.4	0.64	0	3.5	1														
E110D...20///...	1/2"	2	0.1	0	22	20														
E110D...35///...		3.5	0.32	0	10	8														
E110D...52///...		5.2	0.47	0	4	1.8														
E110D...64///...		6.4	0.64	0	3.5	1														
E110B...20///...	1/4"	2	0.1	0	50	40								40	30	27	5	36	PTFE=W ③	-10 +180
E110B...25///...		2.5	0.15	0	35	33														
E110B...35///...		3.5	0.32	0	20	19														
E110B...45///...		4.5	0.41	0	14	13														
E110B...52///...		5.2	0.47	0	10	9														
E110C...20///...	3/8"	2	0.1	0	50	40														
E110C...35///...		3.5	0.32	0	20	19														
E110C...52///...		5.2	0.47	0	10	9														
E110C...64///...		6.4	0.64	0	5	4.5														
E110D...20///...	1/2"	2	0.1	0	50	40														
E110D...35///...		3.5	0.32	0	20	19														
E110D...52///...		5.2	0.47	0	10	9														
E110D...64///...		6.4	0.64	0	5	4.5														

① Seal Example: E110BE35///20E EPDM seal  
 ② Coil Coil 230V 50/60Hz

③ Maximum allowable leakage <0.2NI/h

\* REMARK: The maximum allowable pressure PS for steam is 6bar with PTFE seals and 2,5bar with EPDM seals

COILS	Alternating Current 50/60Hz Volt							Direct Current Volt			Electrical connection	Connectors
	12	24	48	110	220 230	240	380	12	24	48		
Series 2 Width 30 Code ②	20A	20B	20C	20D	20E	20F	20G	200	201	202	DIN 43650A	PG9 code 10349000
Series 5 Width 36 Code ②	52A	52B	52C	52D	52E	52F	52G	520	521	522	DIN 43650A	PG11 code 10349001

**DESCRIPTION**  
 Insulation class  
 Series 2 =F Series 5=H  
 Voltage tolerance  
 AC +15% -10%  
 DC ± 10%  
 Protection class  
 IP65 with connector fitted  
 IP00 without connector  
 Continuous service ED100%

**OPTIONS**  
 Class H insulation (series 2)  
 Cable attached  
 Special coil voltage  
 Special coil powers  
 CE certified coils

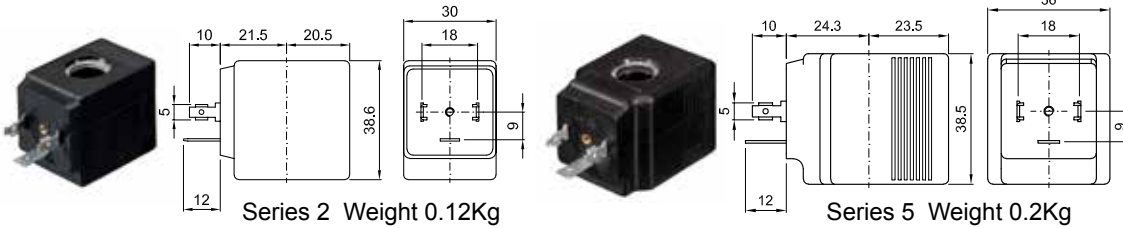

### SPARE PARTS LIST

1. Coil fixing nut
2. Coil
3. Plunger
4. Armature tube with core

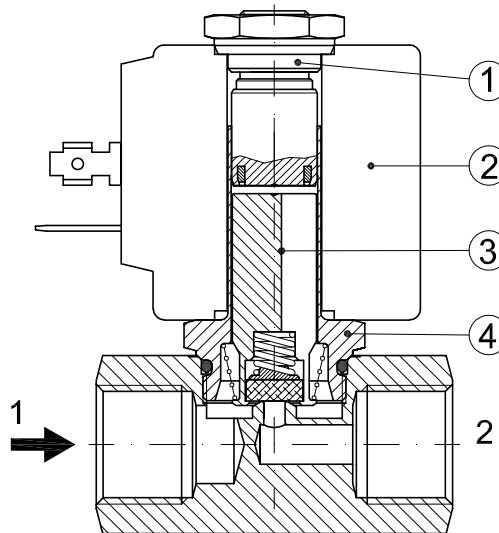

### OVERALL DIMENSION

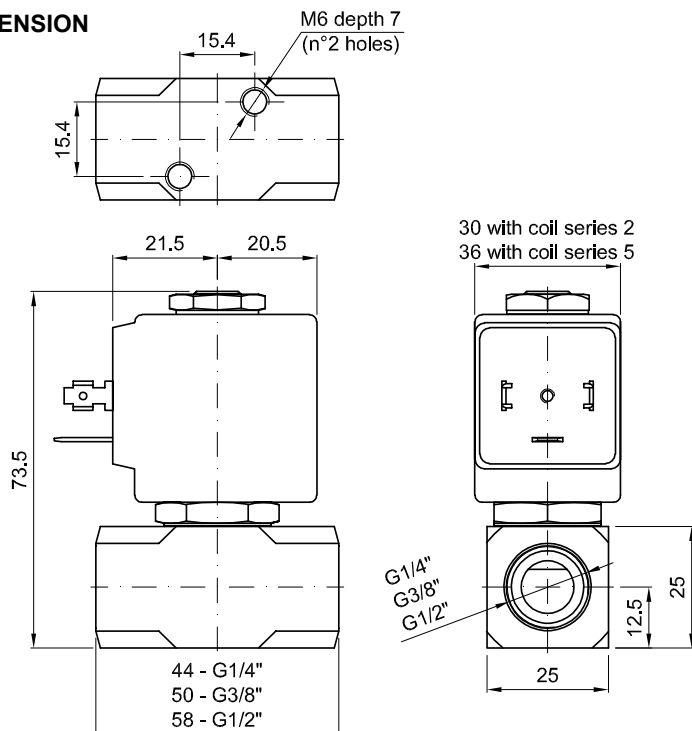

Weight with coil series 2=0.36Kg  
 Weight with coil series 5=0.44Kg

**DESCRIPTION**

Solenoid valve 2 way normally closed  
direct acting poppet type.

With explosion proof coil certified for hazardous area:

**II 2GD Ex d IIC T6 or T5 or T4 Gb**  
**Ex tb IIC T80°C or T95°C or T130°C Db IP66**  
**Tamb -10°C ÷ +35°C(T6) or +50°C(T5) or +60°C(T4)**

(other certifications e.g. Gost-r, Baseefa, CCOE etc. on request)

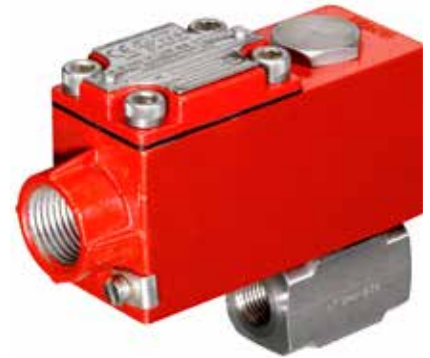

**2**

**VALVE CONSTRUCTION**

Body                                   Stainless steel  
Seal material                         FPM

**EXPLOSION PROOF COIL CONSTRUCTION**

Housing                               Red colour alloy  
Electrical connection             1/2" NPT

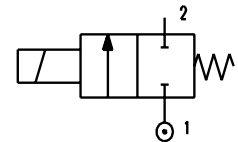

**FEATURES**

Maximum allowable pressure 100bar  
Maximum fluid viscosity 25cSt (mm<sup>2</sup>/s)  
Ambient temperature: -10°C ÷ +35°C(T6), +50°C(T5), +60°C(T4)  
Mounting position with vertical coil above

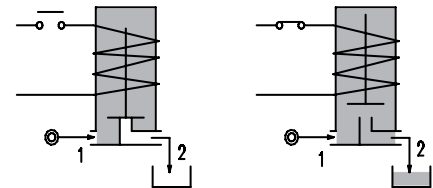

**OPTIONS:** Silver shading ring

**NOTE:** The solenoid valve is suitable only with media that are **NOT** potentially explosive

CODE ②	Connection G ISO 228	Orifice mm	Kv m <sup>3</sup> /h	Differential pressure bar			Nominal power		Coil Series	Seal	Temp. range °C
				Min	Max AC    DC		AC Holding	DC			
A110BV20//...	1/4"	2	0.1	0	22	20	12 VA	8W	A6	FPM=V	-10 +140
A110BV25//...		2.5	0.15	0	16	14					
A110BV35//...		3.5	0.32	0	10	8					
A110BV45//...		4.5	0.41	0	6.5	3.5					
A110BV52//...		5.2	0.47	0	4	1.8					
A110BV64//...		6.4	0.64	0	3.5	1					
A110CV20//...	3/8"	2	0.1	0	22	20	12 VA	8W	A6	FPM=V	-10 +140
A110CV35//...		3.5	0.32	0	10	8					
A110CV52//...		5.2	0.47	0	4	1.8					
A110CV64//...		6.4	0.64	0	3.5	1					
A110DV20//...	1/2"	2	0.1	0	22	20	12 VA	8W	A6	FPM=V	-10 +140
A110DV35//...		3.5	0.32	0	10	8					
A110DV52//...		5.2	0.47	0	4	1.8					
A110DV64//...		6.4	0.64	0	3.5	1					

② Coil

COILS	Alternating Current 50/60Hz Volt				Direct Current Volt			Electrical connection
	24	48	110	220 230	12	24	48	
Series A6 Code ②	A6B	A6C	A6D	A6E	A60	A61	A62	1/2" NPT

**DESCRIPTION**  
 Voltage tolerance  
 AC +15% -10%  
 DC ± 10%  
 Protection class IP66  
 Continuous service ED100%

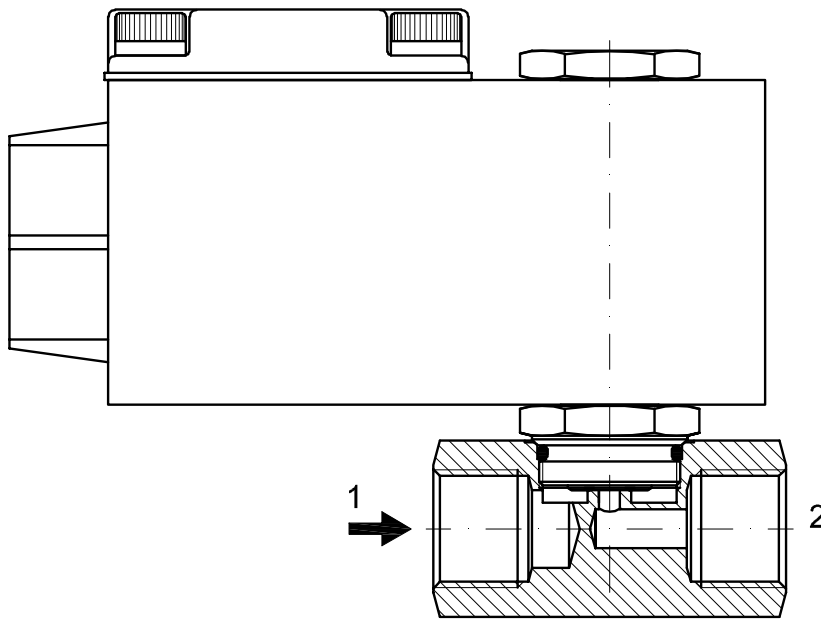

### OVERALL DIMENSION

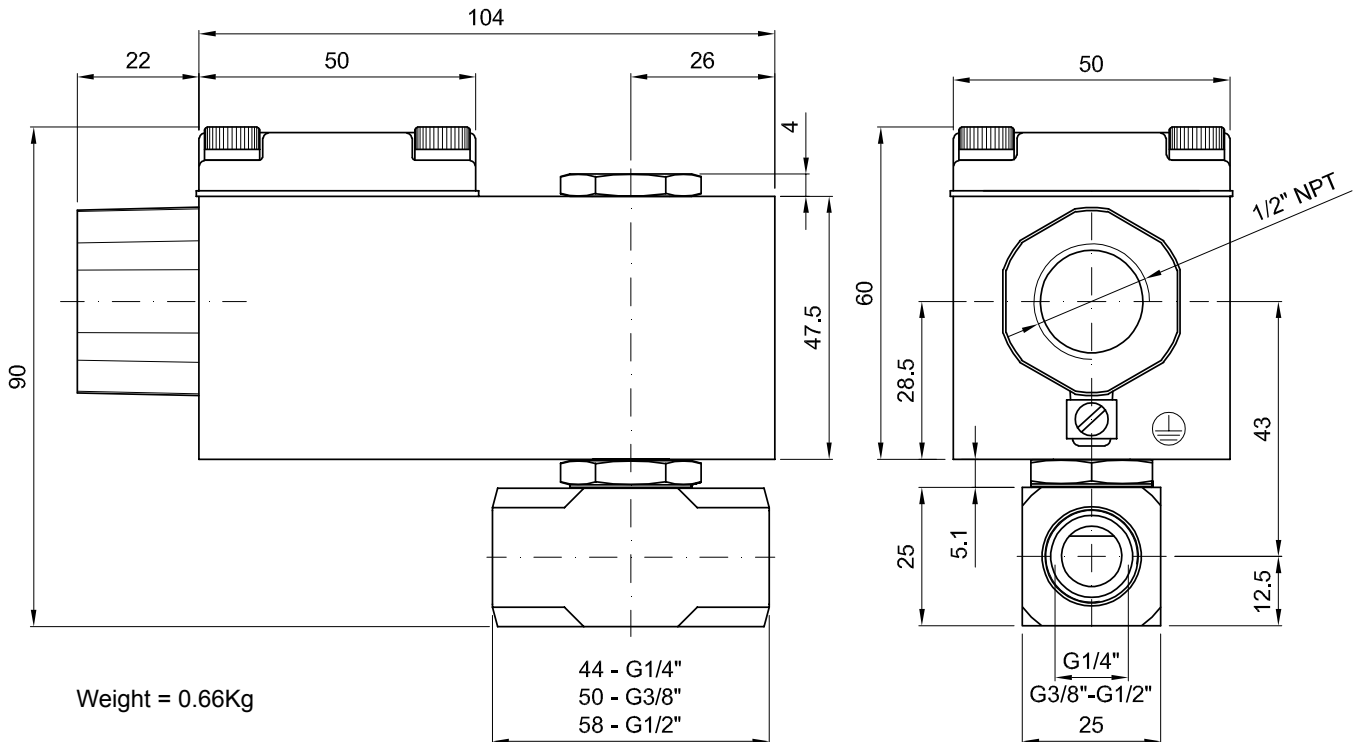

### DESCRIPTION

Solenoid valve 2 way normally closed  
direct acting poppet type

### CONSTRUCTION

Body	Stainless steel
Armature tube	Stainless steel
Plunger and core	Stainless steel
Springs	Stainless steel
Seal material	NBR - FPM - EPDM



### FEATURES

- Maximum allowable pressure 50bar\*
- Maximum fluid viscosity 25cSt (mm<sup>2</sup>/s)
- Ambient temperature:
  - with class F coil -10°C +55°C
  - with class H coil -10°C +80°C
- Universal mounting position

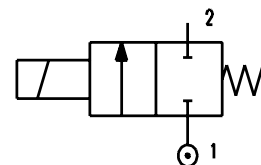

- OPTIONS:**
- Silver shading ring
  - Series 7 explosion proof coil according to ATEX - EExmII
  - Version for use with oxygen
  - UL<sup>®</sup> US certified coils

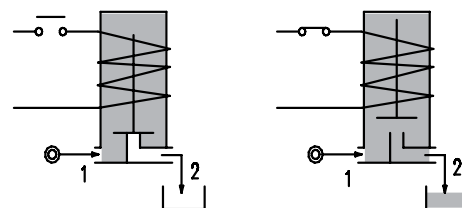

CODE ①    ②	Connection G ISO 228	Orifice mm	Kv m <sup>3</sup> /h	Differential pressure bar			Nominal power			Coil		Seal ①	Temp. range °C
				Min	Max		AC Inrush	VA Holding	DC Watt	Series	Width		
					AC	DC							
E111A...12///...	1/8"	1.2	0.04	0	25	25	12	8	6.5	3	22	NBR=B	-10 +90
E111A...15///...		1.5	0.06	0	16	16							
E111A...20///...		2	0.09	0	12	10							
E111A...25///...		2.5	0.14	0	8	5.5							
E111A...31///...		3.1	0.19	0	5	2							
E111A...20///...	1/8"	2	0.09	0	25	15	15	11	5	4	30	FPM=V	-10 +140
E111A...25///...		2.5	0.14	0	16	8							
E111A...31///...		3.1	0.19	0	8	4							

- ① Seal
  - ② Coil
- Example: E111AB20///30B NBR seal  
Coil 24V 50/60Hz

\* REMARK: The maximum allowable pressure PS for steam is 2,5bar

COILS	Alternating Current 50/60Hz Volt							Direct Current Volt			Electrical connection	Connectors
	12	24	48	110	220 230	240	380	12	24	48		
Series 3 Width 22 Code ②	30A	30B	30C	30D	30E	30F	30G	300	301	302	DIN 46244	PG9 code 10348000
Series 4 Width 30 Code ②	40A	40B	40C	40D	40E	40F	40G	400	401	402	DIN 43650A	PG9 code 10349000

**DESCRIPTION**  
 Class F insulation  
 Voltage tolerance  
 AC +15% -10%  
 DC ± 10%  
 Protection class  
 IP65 with connector fitted  
 IP00 without connector  
 Continuous service ED100%

**OPTIONS**  
 Class H insulation  
 Cable attached  
 Special coil voltage  
 Special coil powers  
 CE certified coils

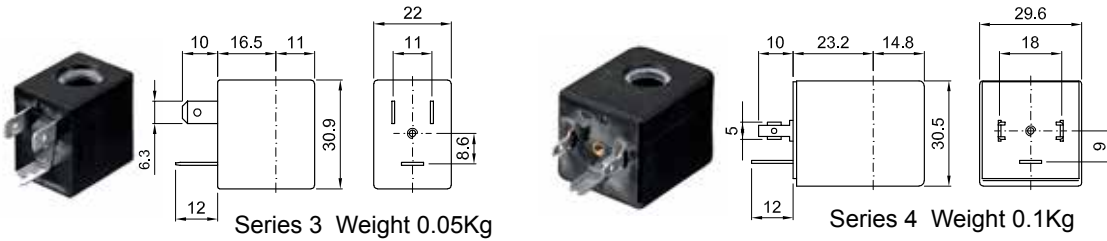

### SPARE PARTS LIST

1. Coil fixing nut
2. Coil
3. Plunger
4. Armature tube with core

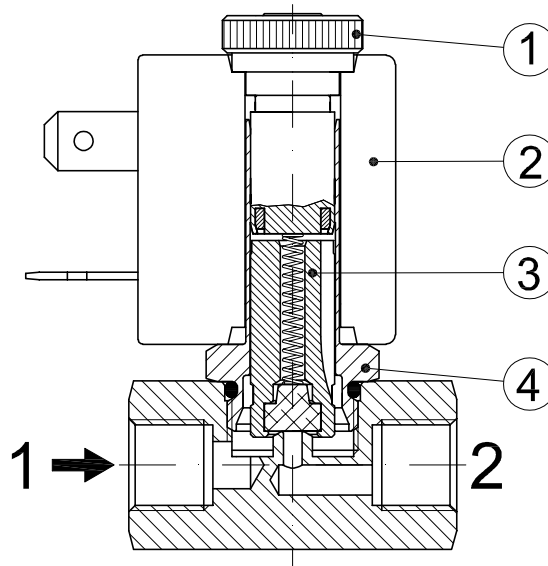

### OVERALL DIMENSION

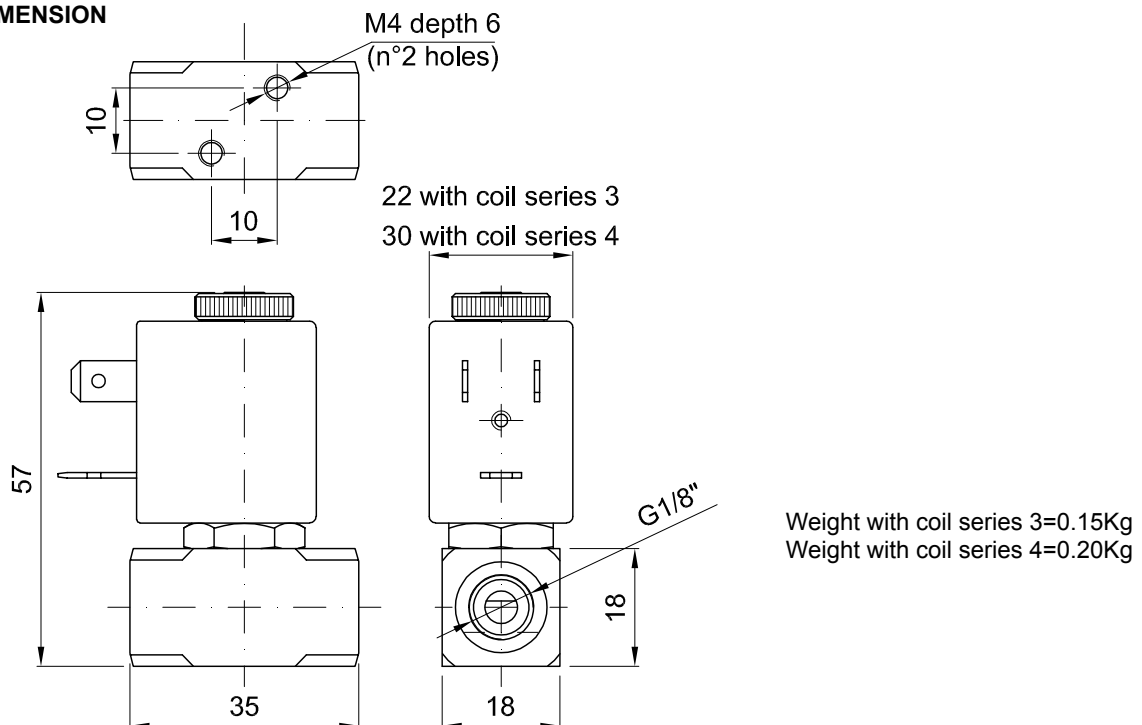



**DESCRIPTION**

Solenoid valve 2 way normally closed  
direct acting poppet type

**CONSTRUCTION**

Body	Brass
Armature tube	Brass
Plunger and core	Stainless steel
Springs	Stainless steel
Seal material	NBR - FPM - EPDM



**2**

**FEATURES**

Maximum allowable pressure 50bar\*  
 Maximum fluid viscosity 25cSt (mm<sup>2</sup>/s)  
 Ambient temperature: with class F coil -10°C +55°C  
 with class H coil -10°C +80°C  
 Universal mounting position

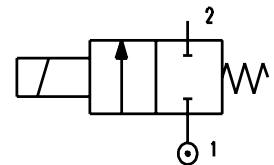

**OPTIONS:** Stainless steel armature tube  
 Electroless nickel plating  
 Series 7 explosion proof coil according to ATEX - EExmII  
 US certified coils

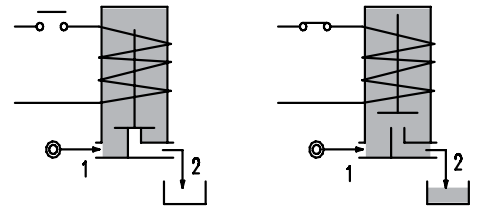

CODE ① ②	Flange □ 25	Orifice mm	Kv m <sup>3</sup> /h	Differential pressure bar			Nominal power			Coil		Seal ①	Temp. range °C
				Min	Max		AC Inrush	VA Holding	DC Watt	Series	Width		
					AC	DC							
E112X...12///...	□ 25	1.2	0.04	0	25	25	12	8	6,5	3	22	NBR=B EPDM=E FPM=V	-10 +90 -10 +140 -10 +140
E112X...15///...		1.5	0.06	0	16	16							
E112X...20///...		2	0.09	0	12	10							
E112X...25///...		2.5	0.14	0	8	5.5							
E112X...20///...	□ 25	2	0.09	0	25	15	15	11	5	4	30	NBR=B EPDM=E FPM=V	-10 +90 -10 +140 -10 +140
E112X...25///...		2.5	0.14	0	16	8							

① Seal Example: E112XB20///30B NBR seal  
 ② Coil Coil 24V 50/60Hz

\* REMARK: The maximum allowable pressure PS for steam is 2,5bar

COILS	Alternating Current 50/60Hz Volt							Direct Current Volt			Electrical connection	Connectors
	12	24	48	110	220 230	240	380	12	24	48		
Series 3 Width 22 Code ②	30A	30B	30C	30D	30E	30F	30G	300	301	302	DIN 46244	PG9 code 10348000
Series 4 Width 30 Code ②	40A	40B	40C	40D	40E	40F	40G	400	401	402	DIN 43650A	PG9 code 10349000

**DESCRIPTION**  
 Class F insulation  
 Voltage tolerance  
 AC +15% -10%  
 DC ± 10%  
 Protection class  
 IP65 with connector fitted  
 IP00 without connector  
 Continuous service  
 ED100%

**OPTIONS**  
 Class H insulation  
 Cable attached  
 Special coil voltage  
 Special coil powers  
 cULus certified coils

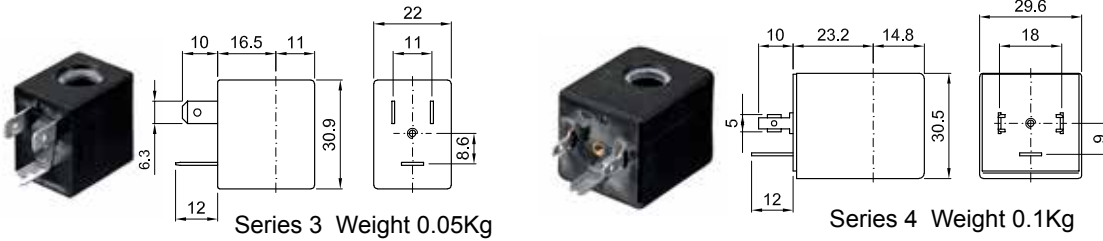

### SPARE PARTS LIST

1. Coil fixing nut
2. Coil
3. Plunger
4. Armature tube with core

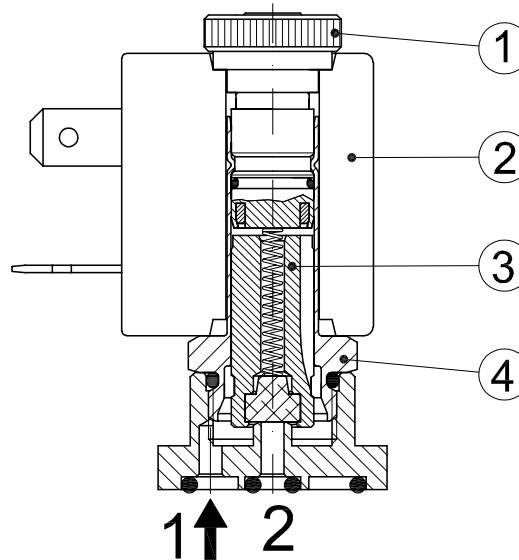

### OVERALL DIMENSION

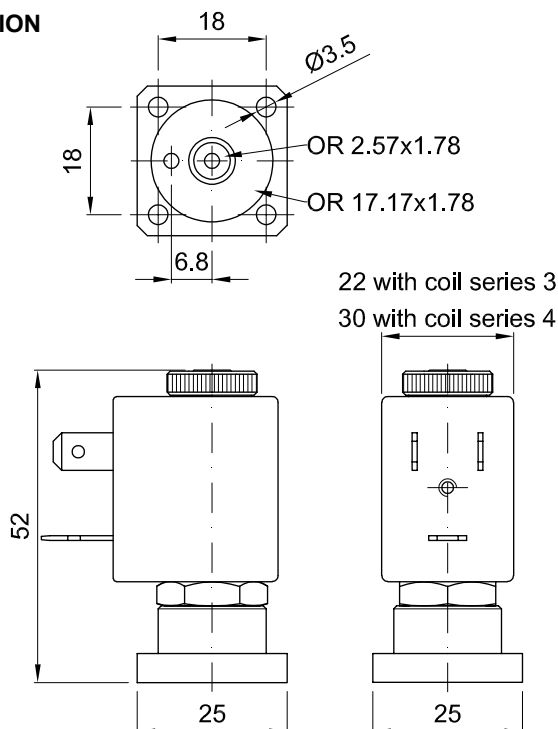

Weight with coil series 3=0.12Kg  
 Weight with coil series 4=0.17Kg

**DESCRIPTION**

Solenoid valve 2 way normally closed  
direct acting poppet type

**CONSTRUCTION**

Body	Brass
Armature tube	Stainless steel
Plunger and core	Stainless steel
Springs	Stainless steel
Seal material	NBR - FPM - EPDM - PTFE



**2**

**FEATURES**

Maximum allowable pressure 50bar\*  
 Maximum fluid viscosity 25cSt (mm<sup>2</sup>/s)  
 Ambient temperature: with class F coil -10°C +55°C  
 with class H coil -10°C +80°C  
 Universal mounting position

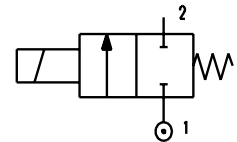

**OPTIONS:** Manual override  
 Electroless nickel plating  
 Stainless steel seat insert  
 Version for use with oxygen  
 c us certified coils

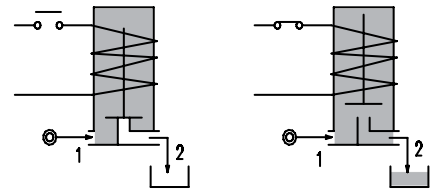

CODE ① ②	Flange □ 32	Orifice mm	Kv m <sup>3</sup> /h	Differential pressure bar			Nominal power			Coil		Seal ①	Temp. range °C
				Min	Max		AC Inrush	VA Holding	DC Watt	Series	Width		
					AC	DC							
E114X...15///...	□ 32	1.5	0.07	0	30	26	20	15	10	2	30	NBR=B EPDM=E FPM=V	-10 +90 -10 +140 -10 +140
E114X...20///...		2	0.1	0	22	20							
E114X...25///...		2.5	0.15	0	16	14							
E114X...35///...		3.5	0.32	0	10	8							
E114X...45///...		4.5	0.41	0	6.5	3.5							
E114X...25///...	□ 32	2.5	0.15	0	35	33	40	30	27	5	36	PTFE=W ③	-10 +180
E114X...35///...		3.5	0.32	0	20	19							
E114X...45///...		4.5	0.41	0	14	13							

- ① Seal Example: E114XB25///20E NBR seal
- ② Coil Coil 230V 50/60Hz
- ③ Maximum allowable leakage <0.2NI/h

\* REMARK: The maximum allowable pressure PS for steam is 6bar with PTFE seals and 2,5bar with EPDM seals

COILS	Alternating Current 50/60Hz Volt							Direct Current Volt			Electrical connection	Connectors
	12	24	48	110	220 230	240	380	12	24	48		
Series 2 Width 30 Code ②	20A	20B	20C	20D	20E	20F	20G	200	201	202	DIN 43650A	PG9 code 10349000
Series 5 Width 36 Code ②	52A	52B	52C	52D	52E	52F	52G	520	521	522	DIN 43650A	PG11 code 10349001

**DESCRIPTION**  
 Insulation class  
 Series 2 =F Series 5=H  
 Voltage tolerance  
 AC +15% -10%  
 DC ± 10%  
 Protection class  
 IP65 with connector fitted  
 IP00 without connector  
 Continuous service ED100%

**OPTIONS**  
 Class H insulation (series 2)  
 Cable attached  
 Special coil voltage  
 Special coil powers  
 CE certified coils

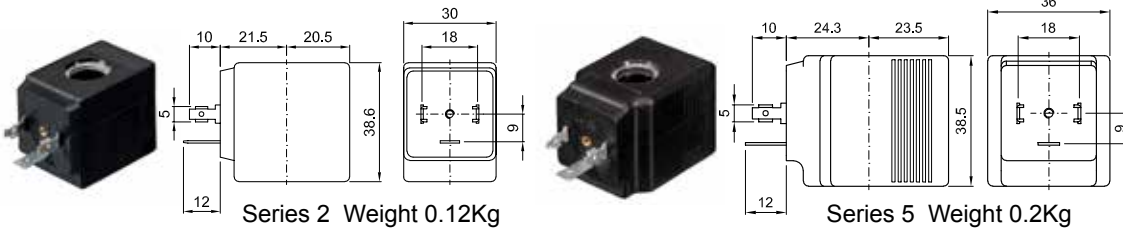

Series 2 Weight 0.12Kg

Series 5 Weight 0.2Kg

### SPARE PARTS LIST

1. Coil fixing nut
2. Coil
3. Plunger
4. Armature tube with core

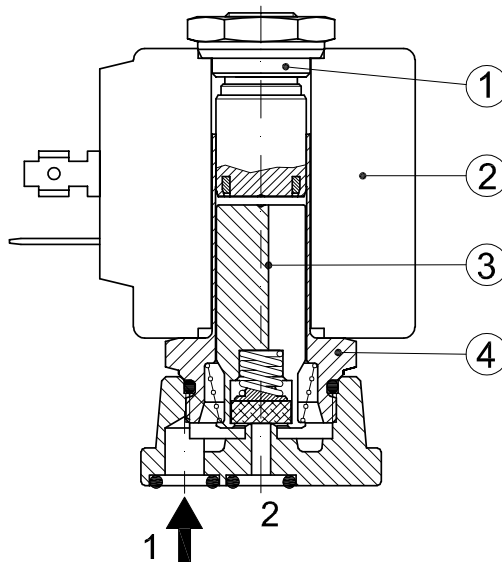

### MANUAL OVERRIDE

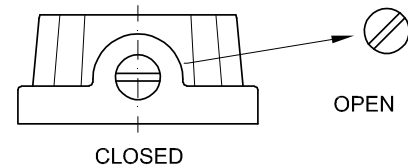

### OVERALL DIMENSION

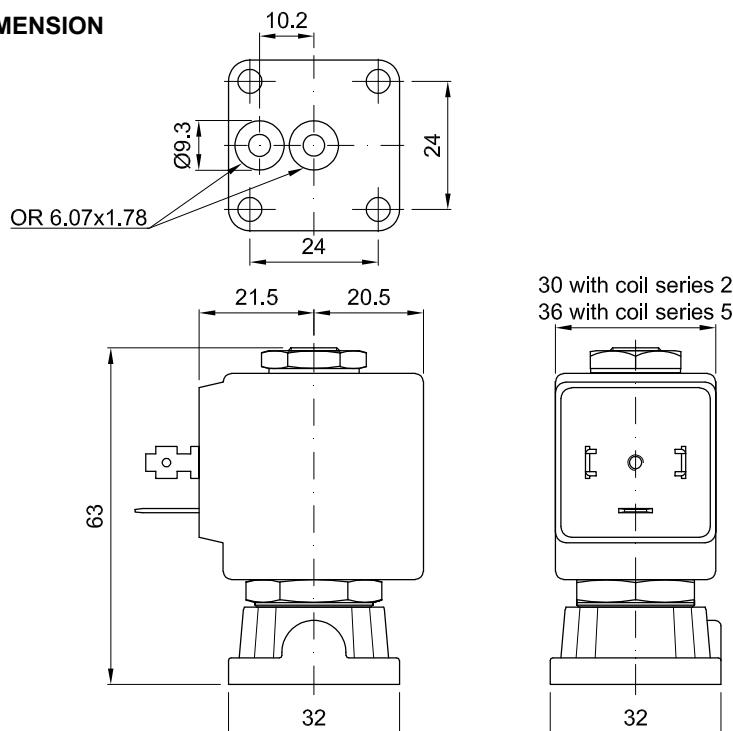

Weight with coil series 2=0.24Kg  
 Weight with coil series 5=0.32Kg

**DESCRIPTION**

Solenoid valve 2 way direct acting poppet type.  
 Bi-stable impulse drive.  
 The bi-stable function is achieved by the use of a polarized permanent magnet energizing the coil with a DC current for at least 15ms in the reverse direction of the preceding impulse.



**2**

**CONSTRUCTION**

Body	Brass
Armature tube	Brass
Plunger and core	Stainless steel
Magnet	NeFeB
Springs	Stainless steel
Seal material	NBR - FPM - EPDM

**FEATURES**

Maximum allowable pressure 50bar\*  
 Maximum fluid viscosity 25cSt (mm<sup>2</sup>/s)  
 Ambient temperature: with class F coil -10°C +55°C  
 with class H coil -10°C +80°C  
 Universal mounting position

**OPTIONS:** Stainless steel armature tube  
 Electroless nickel plating  
 Series 7 explosion proof coil according to ATEX - EExmII  
 Special powers

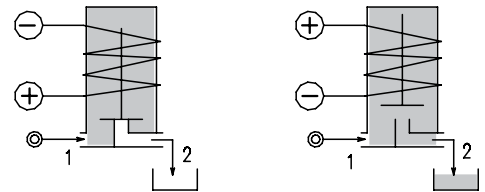
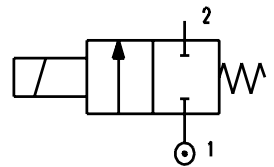

CODE ① ②	Connection G ISO 228	Orifice mm	Kv m <sup>3</sup> /h	Differential pressure bar		Nominal power DC Watt	Coil		Seal ①	Temp. range °C		
				Min	Max		Series	Width				
D115A...12///...	1/8"	1.2	0.04	0	12	2	3	22	NBR=B	-10 +90		
D115A...15///...	1/8"	1.5	0.06	0	8	2						
		1.5	0.06	0	20	5						
D115A...20///...	1/8"	2	0.09	0	3	2						
		2	0.09	0	12	5						
D115A...25///...	1/8"	2.5	0.14	0	1	2						
		2.5	0.14	0	5	5						
		2.5	0.14	0	8	6.5						
D115A...31///...	1/8"	3.1	0.19	0	2	5						
		3.1	0.19	0	3.5	6.5						
											EPDM=E	-10 +140
											FPM=V	-10 +140

- ① Seal
- ② Coil

Example: D115AB20///300120 NBR seal  
 Coil 12V DC 2W

COILS	Direct Current															Electrical connection	Connectors
	3V			6V			9V			12V			24V				
	2W	5W	6.5W	2W	5W	6.5W	2W	5W	6.5W	2W	5W	6.5W	2W	5W	6.5W		
Series 3 Width 22 Code ②	308120			305120	305150		307120	307150		300120	300150	300	301120	301150	301	DIN 46244	PG9 code 10348000

**DESCRIPTION**  
 Class F insulation  
 Voltage tolerance  $\pm 10\%$   
 Protection class  
 IP65 with connector fitted  
 IP00 without connector  
 Continuous service ED100%

**OPTIONS**  
 Class H insulation  
 Cable attached  
 Special coil voltage  
 Special coil powers

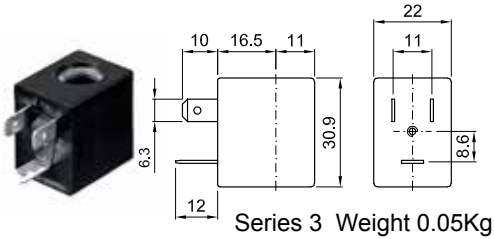

### SPARE PARTS LIST

1. Coil fixing nut
2. Coil
3. Plunger
4. Armature tube with core

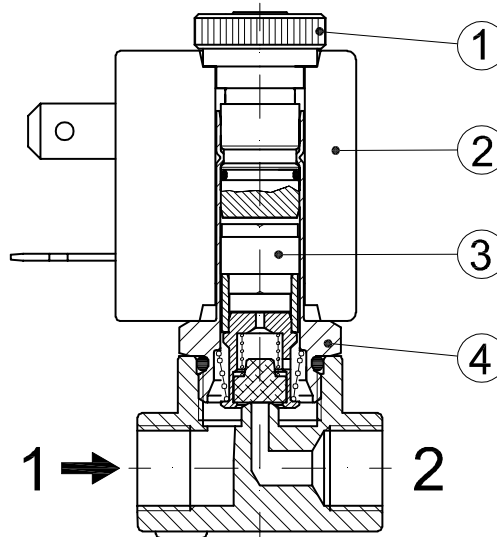

### OVERALL DIMENSION

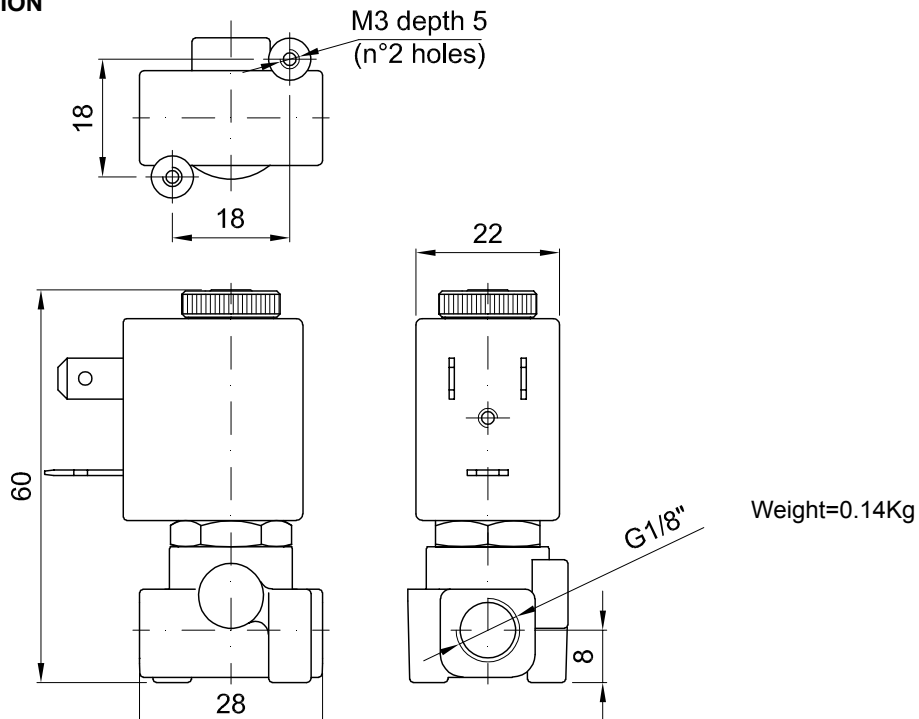

**DESCRIPTION**

Solenoid valve 2 way direct acting poppet type.  
 Bi-stable impulse drive.  
 The bi-stable function is achieved by the use of a polarized permanent magnet energizing the coil with a DC current for at least 15ms in the reverse direction of the preceding impulse.



**2**

**CONSTRUCTION**

Body	Brass
Armature tube	Stainless steel
Plunger and core	Stainless steel
Magnet	NeFeB
Springs	Stainless steel
Seal material	NBR - FPM - EPDM

**FEATURES**

Maximum allowable pressure 50bar\*  
 Maximum fluid viscosity 25cSt (mm<sup>2</sup>/s)  
 Ambient temperature: with class F coil -10°C +55°C  
 with class H coil -10°C +80°C  
 Universal mounting position

**OPTIONS:** Manual override  
 Electroless nickel plating  
 Stainless steel seat insert

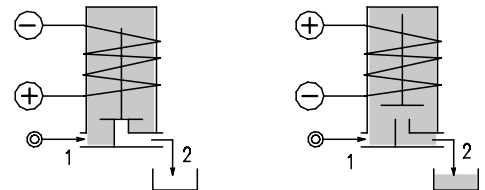
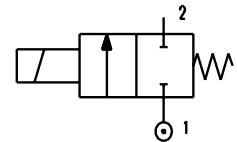

CODE ① ②	Connection G ISO 228	Orifice mm	Kv m <sup>3</sup> /h	Differential pressure bar		Nominal power DC Watt	Coil		Seal ①	Temp. range °C
				Min	Max		Series	Width		
D116A...15///...	1/8"	1.5	0.07	0	26	10	2	30	NBR=B	-10 +90
D116A...20///...		2	0.1	0	20					
D116A...25///...		2.5	0.15	0	14					
D116A...35///...		3.5	0.32	0	8					
D116B...15///...	1/4"	1.5	0.07	0	26					
D116B...20///...		2	0.1	0	20					
D116B...25///...		2.5	0.15	0	14					
D116B...35///...		3.5	0.32	0	8					
D116B...45///...	3/8"	4.5	0.41	0	3.5					
D116B...52///...		5.2	0.47	0	1.8					
D116C...30///...		1/2"	3	0.25	0				10	
D116C...35///...			3.5	0.32	0				8	
D116C...40///...	4		0.36	0	5					
D116C...45///...	4.5		0.41	0	3.5					
D116C...52///...	1/2"	5.2	0.47	0	1.8					
D116D...30///...		1/2"	3	0.25	0				10	
D116D...35///...			3.5	0.32	0	8				
D116D...40///...			4	0.36	0	5				
D116D...45///...	4.5		0.41	0	3.5					
D116D...52///...	1/2"	5.2	0.47	0	1.8					

① Seal Example: D116BB25///201 NBR seal  
 ② Coil Coil 24V DC 10W

\* REMARK: The maximum allowable pressure PS for steam is 6bar with PTFE seals and 2,5bar with EPDM seals

COILS	Direct Current Volt			Electrical connection	Connectors
	12	24	48		
Series 2 Width 30 Code ②	200	201	202	DIN 43650A	PG9 code 10349000

**DESCRIPTION**  
 Insulation class F  
 Voltage tolerance  $\pm 10\%$   
 Protection class  
 IP65 with connector fitted  
 IP00 without connector

**OPTIONS**  
 Class H insulation  
 Cable attached  
 Special coil voltage  
 Special coil powers

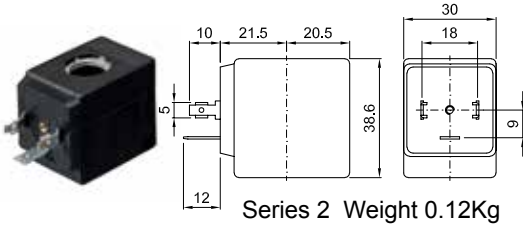

Series 2 Weight 0.12Kg

### SPARE PARTS LIST

1. Coil fixing nut
2. Coil
3. Plunger
4. Armature tube with core

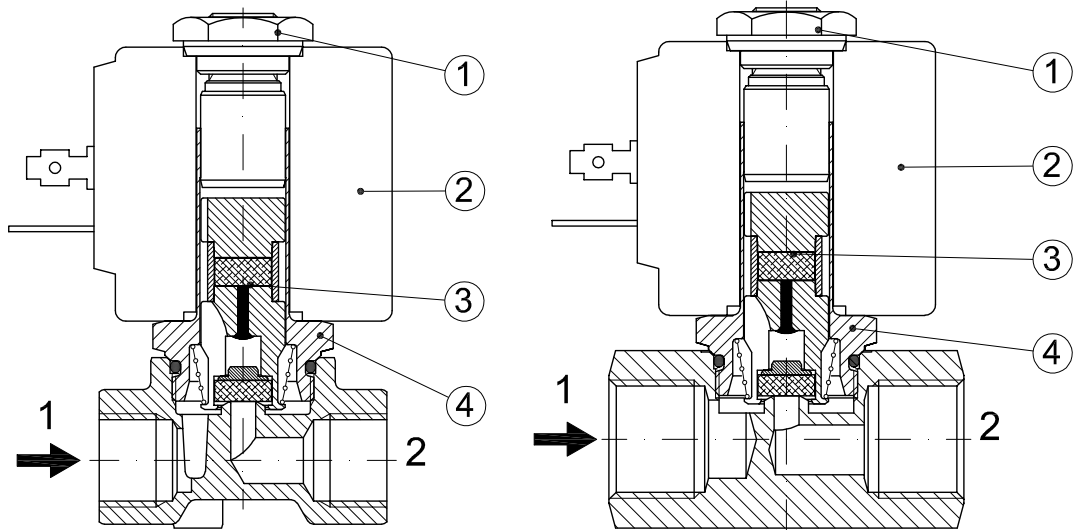

### OVERALL DIMENSION

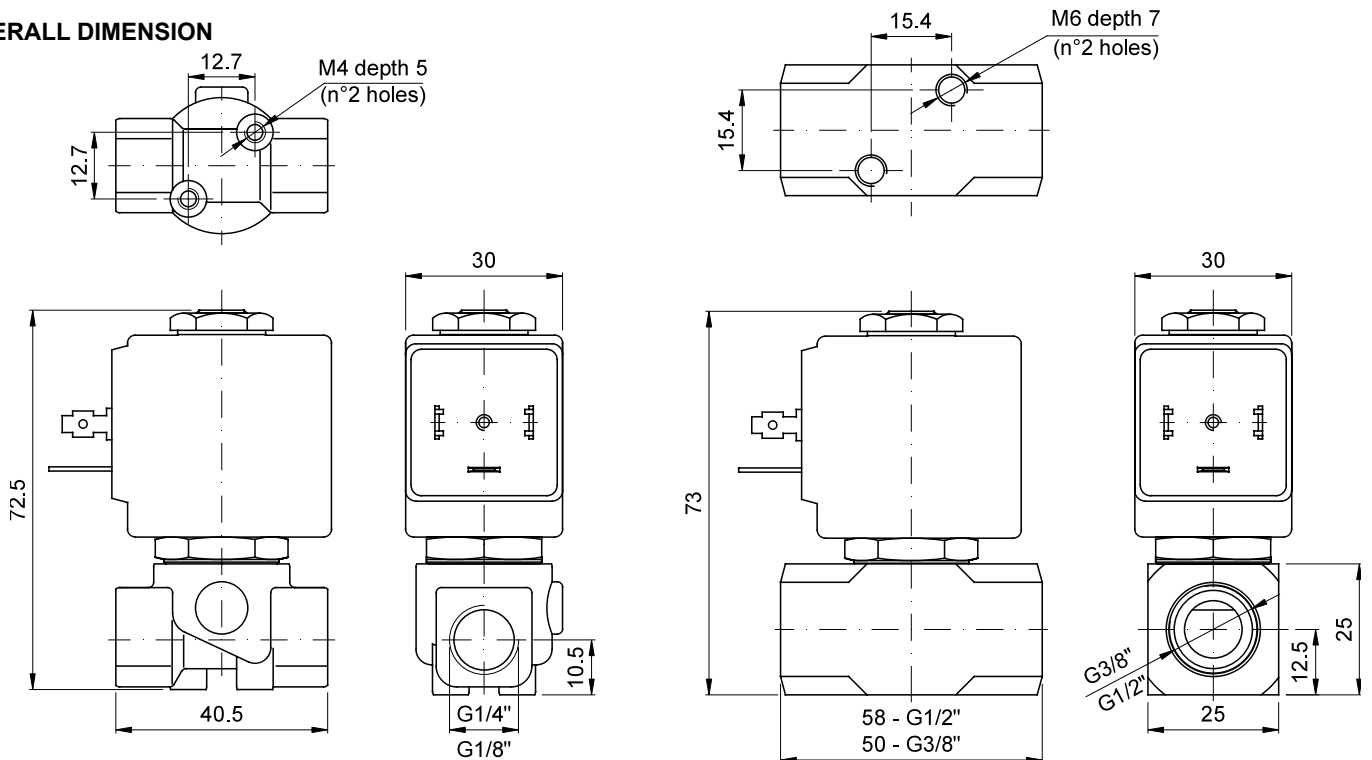



**DESCRIPTION**

Solenoid valve 2 way normally closed  
direct acting poppet type

**CONSTRUCTION**

Body	Brass
Armature tube	Brass
Plunger and core	Stainless steel
Springs	Stainless steel
Seal material	NBR - FPM



**2**

**FEATURES**

Maximum allowable pressure 30bar\*  
Maximum fluid viscosity 25cSt (mm<sup>2</sup>/s)  
Ambient temperature:      with class F coil -10°C +55°C  
                                    with class H coil -10°C +80°C  
Universal mounting position

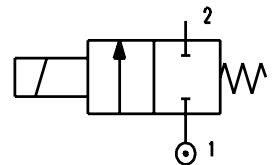

**OPTIONS:** Electroless nickel plating

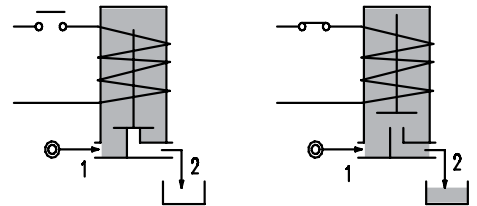

CODE ① ②	Connection	Orifice mm	Kv m <sup>3</sup> /h	Differential pressure bar			Nominal power			Coil		Seal ①	Temp. range °C
				Min	Max		AC Inrush	VA Holding	DC Watt	Series	Width		
					AC	DC							
D121L...10///...	M5	1	0.03	0	-	10	-	-	2	6	16	NBR=B FPM=V	-10 +90 -10 +140
D121L...12///...		1.2	0.037	0	-	7	-	-	2				
D121L...12///...		1.2	0.037	0	-	12	-	-	4				
D121L...16///...		1.6	0.055	0	-	3	-	-	2				
D121L...16///...		1.6	0.055	0	-	8	-	-	4				
D121L...20///...		2	0.082	0	-	1.4	-	-	2				
D121L...20///...		2	0.082	0	-	4	-	-	4				

① Seal   Example: D121LV12///60112 NBR seal  
② Coil    Coil 24V DC 2W

\* REMARK: The maximum allowable pressure PS for steam is 2,5bar

COILS	Direct Current				Electrical connection	Connectors
	12V		24V			
	2W	4W	2W	4W		
Series 6 Width 16 Code ②	60012	60014	60112	60114	AMP 2.8x0.5	PG7 code 10348040

**DESCRIPTION**  
 Class F insulation  
 Voltage tolerance  $\pm 5\%$   
 Protection class  
 IP65 with connector fitted  
 IP00 without connector  
 Continuous service ED100%

**OPTIONS**  
 Cable attached  
 Special coil voltage  
 Special coil powers

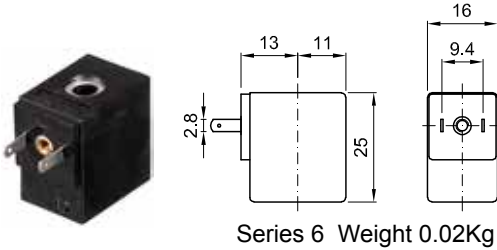

Series 6 Weight 0.02Kg

### SPARE PARTS LIST

1. Coil fixing nut
2. Coil
3. Plunger
4. Armature tube with core

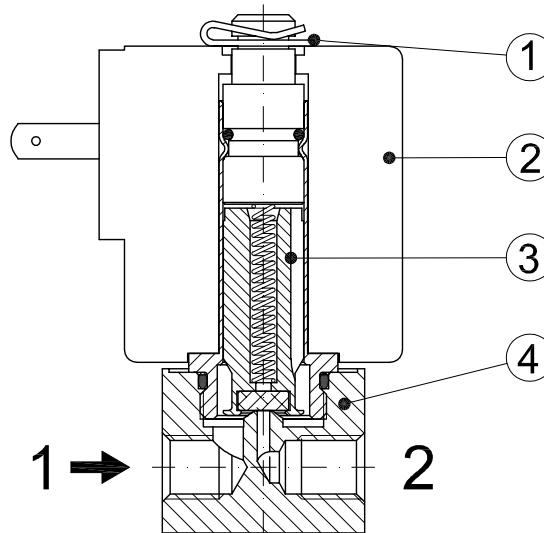

### OVERALL DIMENSION

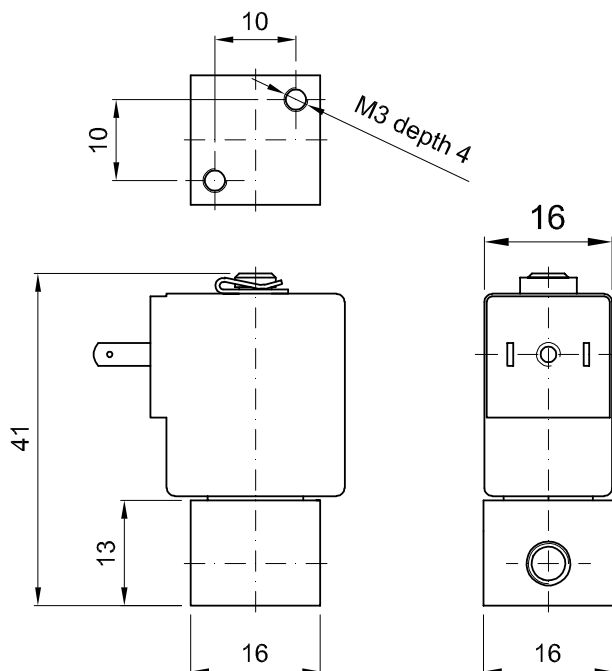

Weight = 0.05Kg

**DESCRIPTION**

Solenoid valve 2 way normally closed direct acting poppet type, suitable for food applications and all compatible fluids.

**CONSTRUCTION**

Body	Thermoplastic polymer NSF, WRC, KTW, FDA certified
Armature tube	Brass chemically nickel plated
Plunger and core	Stainless steel
Springs	Stainless steel
Seal material	NBR - FPM - EPDM (food contact certified)



2

**FEATURES**

Maximum allowable pressure 30bar\*  
 Maximum fluid viscosity 25cSt (mm<sup>2</sup>/s)  
 Ambient temperature: with class F coil -10°C +55°C  
 with class H coil -10°C +80°C  
 Universal mounting position

**OPTIONS:** Stainless steel armature tube  
 Type N connection without nut  
 cULus certified coils

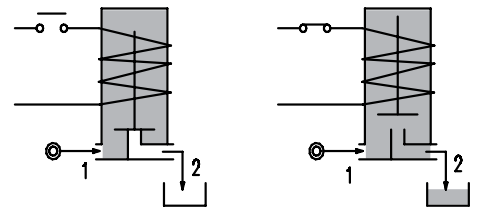
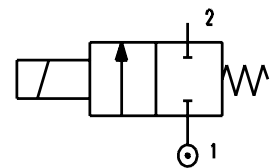

CONNECTION					
K	N	P	W	Y	Z
<b>SPIGGOT</b>	<b>G1/8" male thread with NUT for flexible pipes</b>	<b>HOSETAIL for flexible pipes</b>	<b>COMPRESSION for flexible and semiflexible pipes</b>	<b>PUSH IN for semiflexible pipes Øext 6</b>	<b>PUSH IN for semiflexible pipes Øext 4</b>

CODE ① ②	Connection *	Orifice mm	Kv m <sup>3</sup> /h	Differential pressure bar			Nominal power			Coil		Seal ①	Temp. range ** °C
				Min	Max		AC Inrush	VA Holding	DC Watt	Series	Width		
					AC	DC							
E135*...15///...	K-N-P-W-Y-Z	1.5	0.06	0	16	16	12	8	6.5	3	22	NBR=A	-10 +90
E135*...20///...	K-N-P-W-Y-Z	2	0.09	0	12	10							
E135*...25///...	K-N-P-W-Y-Z	2.5	0.14	0	8	5.5							
E135*...30///...	K-N-P-Y	3	0.19	0	4.5	2							
E135*...40///...	N-P-Y	4	0.35	0	2.5	1.2	15	11	5	4	30	EPDM=E	-10 +140
E135*...20///...	K-N-P-W-Y-Z	2	0.09	0	25	15							
E135*...25///...	K-N-P-W-Y-Z	2.5	0.14	0	16	8							
E135*...30///...	K-N-P-Y	3	0.19	0	8	4							
E135*...40///...	N-P-Y	4	0.35	0	5	2.5						FPM=V	-10 +140

① Seal Example: E135KA20///30B NBR seal SPIGGOT connection  
 ② Coil Coil 24V 50/60Hz  
 ③ Only for connection "W" E135W.../1/...

\* REMARK: The maximum allowable pressure PS for steam is 2,5bar

\*\* The temperature range is related to the material of the seals (NBR, EPDM, FPM), and the valves' body. Please contact us concerning the temperature range referred to the different types of connection.

COILS	Alternating Current 50/60Hz Volt							Direct Current Volt			Electrical connection	Connectors
	12	24	48	110	220 230	240	380	12	24	48		
Series 3 Width 22 Code ②	30A	30B	30C	30D	30E	30F	30G	300	301	302	DIN 46244	PG9 code 10348000
Series 4 Width 30 Code ②	40A	40B	40C	40D	40E	40F	40G	400	401	402	DIN 43650A	PG9 code 10349000

**DESCRIPTION**  
 Class F insulation  
 Voltage tolerance  
 AC +15% -10%  
 DC ± 10%  
 Protection class  
 IP65 with connector fitted  
 IP00 without connector  
 Continuous service ED100%

**OPTIONS**  
 Class H insulation  
 Cable attached  
 Special coil voltage  
 Special coil powers  
 us certified coils

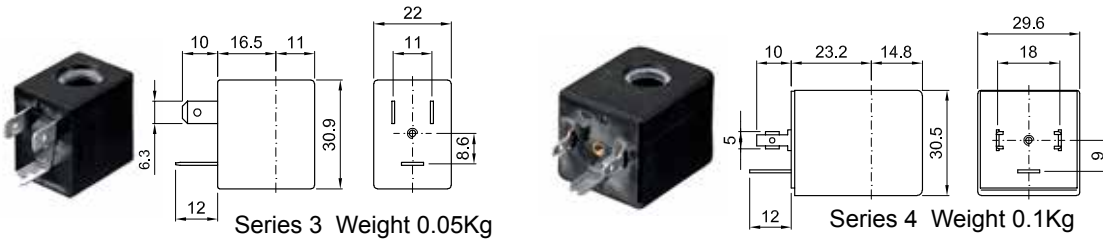

Series 3 Weight 0.05Kg

Series 4 Weight 0.1Kg

### SPARE PARTS LIST

1. Coil fixing nut
2. Coil
3. Plunger
4. Armature tube with core

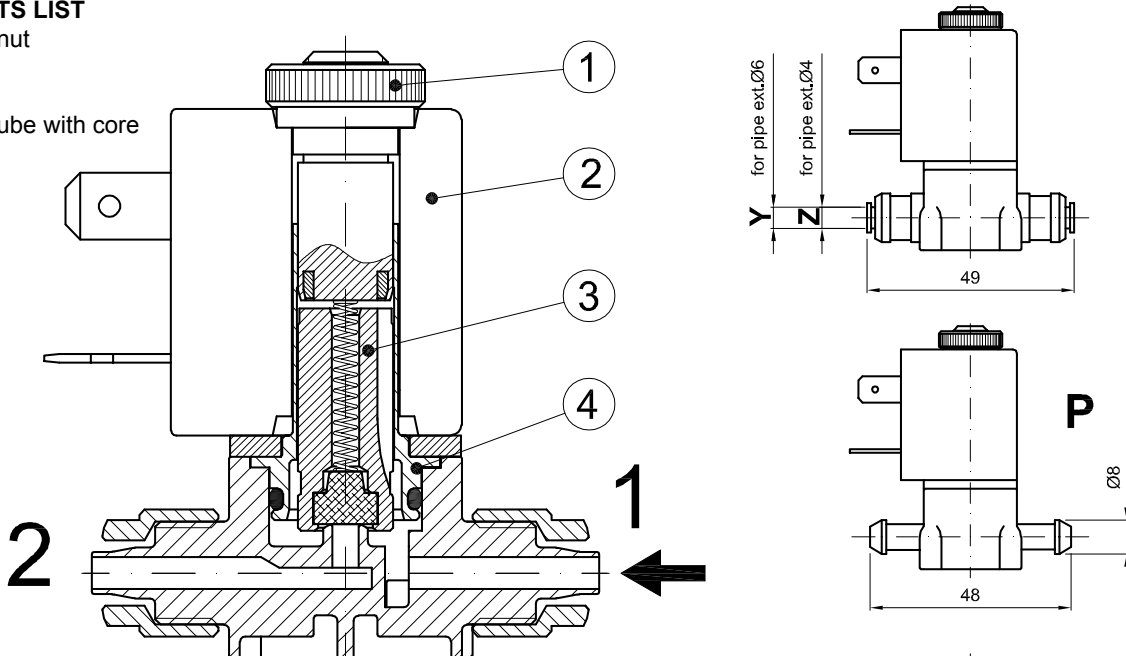

Weight with coil series 3=0.10Kg  
 Weight with coil series 4=0.15Kg

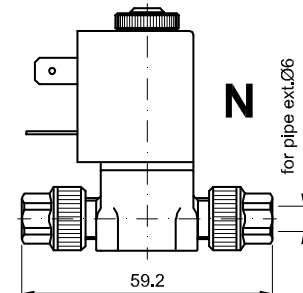
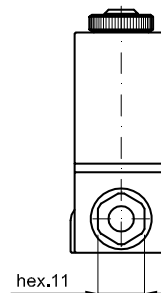
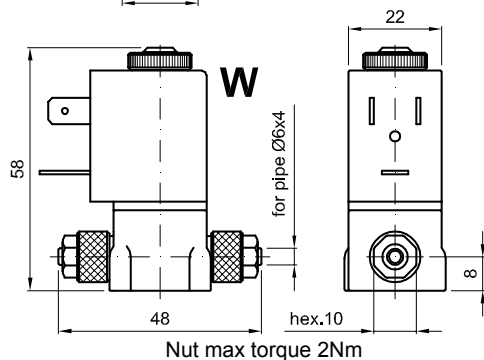
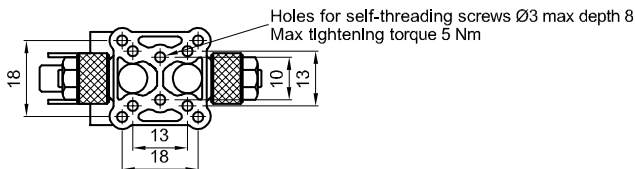

Screw the nut with wrench 11 up to the sliding on the hexagon (torque limiting device)

**DESCRIPTION**

Solenoid valve 2 way normally closed  
 direct acting with dry armature.  
 No metal parts in contact with the media.

**CONSTRUCTION**

Body	Acetal copolymer
Armature tube	Brass
Plunger and core	Stainless steel
Springs	Stainless steel
Seal material	SILICONE



**2**

**FEATURES**

Maximum allowable pressure 2bar  
 Maximum fluid viscosity 25cSt (mm<sup>2</sup>/s)  
 Ambient temperature: with class F coil -10°C +55°C  
 with class H coil -10°C +80°C  
 Preferred mounting position with vertical coil above

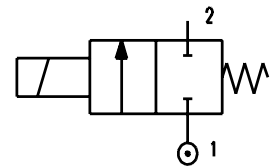

**OPTIONS:** us certified coils

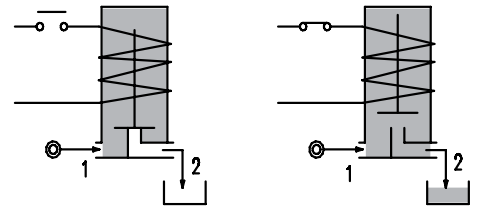

**Version with closed vent**

CODE ②	Connection G ISO 228	Orifice mm	Kv m <sup>3</sup> /h	Differential pressure bar			Nominal power			Coil		Seal ①	Temp. range °C
				Min	Max		AC Inrush	VA Holding	DC Watt	Series	Width		
					AC	DC							
E150PS75//...	-	7.5	0.7	0	0.2	0.2	12	8	6.5	3	22	SILICONE=S	<+95°C
E150PS75/6/...	1/4"			0	0.2	0.2							
D150PS75//...	-			0	-	0.2							
D150PS75/5/...	1/4"			0	-	0.2							

**Version with open vent**

CODE ②	Connection G ISO 228	Orifice mm	Kv m <sup>3</sup> /h	Differential pressure bar			Nominal power			Coil		Seal ①	Temp. range °C
				Min	Max		AC Inrush	VA Holding	DC Watt	Series	Width		
					AC	DC							
E150PS75/7/...	-	7.5	0.7	0	0.2	0.2	12	8	6.5	3	22	SILICONE=S	<+95°C
E150PS75/1/...	1/4"			0	0.2	0.2							
D150PS75/4/...	-			0	-	0.2							
D150PS75/3/...	1/4"			0	-	0.2							

② Coil

Example: E150PS75/6/30B G1/4" inlet - Closed vent  
 Coil 24V 50/60Hz

COILS	Alternating Current 50/60Hz Volt							Direct Current Volt			Electrical connection	Connectors
	12	24	48	110	220 230	240	380	12	24	48		
Series 3 Width 22 Code ②	30A	30B	30C	30D	30E	30F	30G	300	301	302	DIN 46244	PG9 code 10348000

**DESCRIPTION**  
 Class F insulation  
 Voltage tolerance  
 AC +15% -10%  
 DC ± 10%  
 Protection class  
 IP65 with connector fitted  
 IP00 without connector  
 Continuous service ED100%

**OPTIONS**  
 Class H insulation  
 Cable attached  
 Special coil voltage  
 Special coil powers  
 cULus certified coils

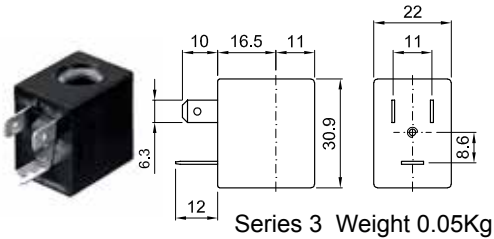

Series 3 Weight 0.05Kg

### SPARE PARTS LIST

1. Coil fixing nut
2. Coil
3. Diaphragm

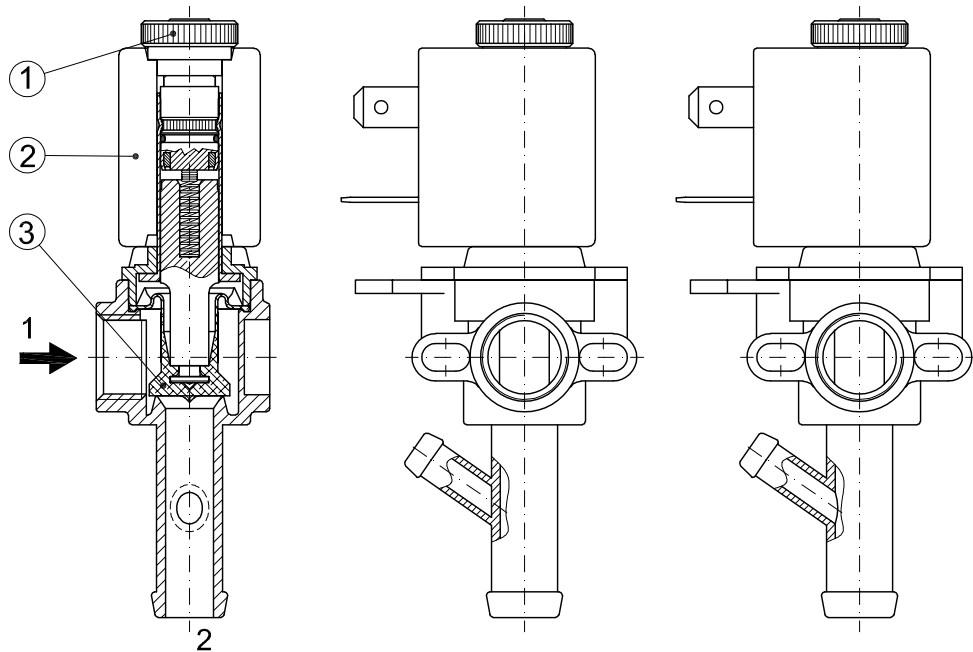

### OVERALL DIMENSION

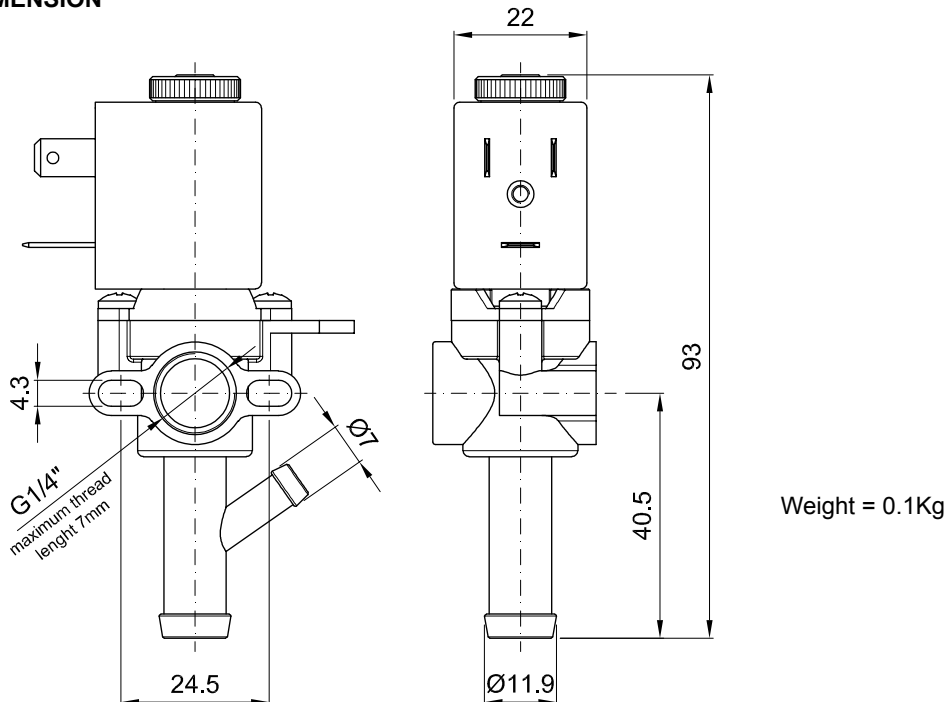

**DESCRIPTION**

Solenoid valve 2 way normally closed  
 direct acting with dry armature.  
 No metal parts in contact with the media.

**CONSTRUCTION**

Body	Acetal copolymer
Armature tube	Brass
Plunger and core	Stainless steel
Springs	Stainless steel
Seal material	SILICONE



**2**

**FEATURES**

Maximum allowable pressure 2bar  
 Maximum fluid viscosity 25cSt (mm<sup>2</sup>/s)  
 Ambient temperature: with class F coil -10°C +55°C  
 with class H coil -10°C +80°C  
 Preferred mounting position with vertical coil above

**OPTIONS:** Nickel plated armature tube  
 For connection accessories see section 9  
 c us certified coils

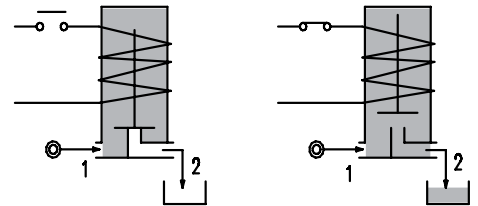
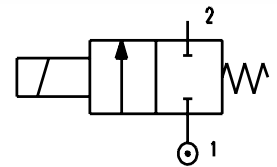

CONNECTION				
E151BBS70	E151PPS60	E151PPS40	E151BPS60	E151BPS40
G1/4"	Hosetail DN6	Hosetail DN4	G1/4"-Hosetail DN6	G1/4"-Hosetail DN4

**OTHER CONFIGURATION AVAILABLE ON REQUEST**

CODE ②	Connection	Orifice mm	Kv m <sup>3</sup> /h	Differential pressure bar			Nominal power			Coil		Temp. range °C	
				Min	Max		AC Inrush	VA Holding	DC Watt	Series	Width		Seal ①
					AC	DC							
E151BBS70///...	G1/4"	7	0.83	0	0.6	0.3	12	8	6.5	3	22	SILICONE=S	<+95°C
E151PPS60///...	Hosetail DN6	6	0.63	0	0.6	0.3							
E151PPS40///...	Hosetail DN4	4	0.34	0	0.6	0.3							
E151BPS60///...	G1/4"-Hosetail DN6	6	0.63	0	0.6	0.3							
E151BPS40///...	G1/4"-Hosetail DN4	4	0.34	0	0.6	0.3							

② Coil Example: E151BPS60///30B G1/4" inlet, hosetail DN6 outlet  
 Coil 24V 50/60Hz

**FOR HIGHER DIFFERENTIAL PRESSURE CONTACT THE MANUFACTURER**

COILS	Alternating Current 50/60Hz Volt							Direct Current Volt			Electrical connection	Connectors
	12	24	48	110	220 230	240	380	12	24	48		
Series 3 Width 22 Code ②	30A	30B	30C	30D	30E	30F	30G	300	301	302	DIN 46244	PG9 code 10348000

**DESCRIPTION**  
 Class F insulation  
 Voltage tolerance  
 AC +15% -10%  
 DC ± 10%  
 Protection class  
 IP65 with connector fitted  
 IP00 without connector  
 Continuous service ED100%

**OPTIONS**  
 Class H insulation  
 Cable attached  
 Special coil voltage  
 Special coil powers  
 cULUS certified coils

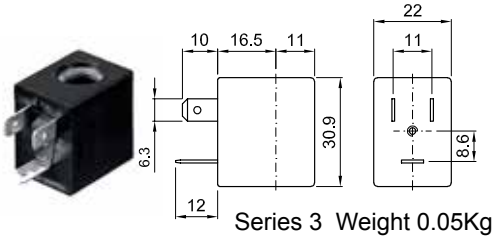

### SPARE PARTS LIST

1. Coil fixing nut
2. Coil
3. Plunger
4. Armature tube with core

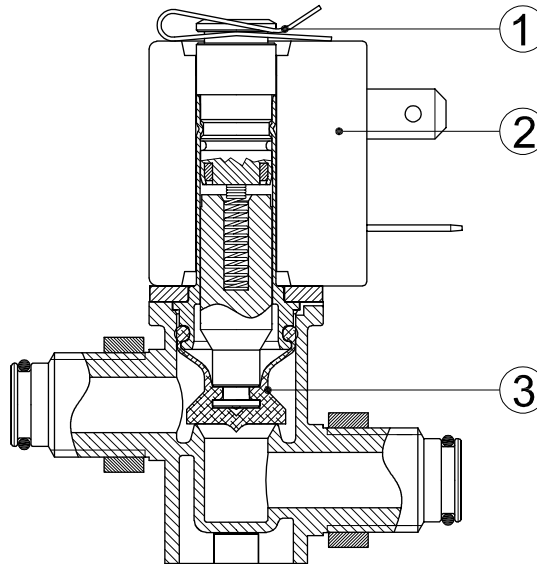

### OVERALL DIMENSION

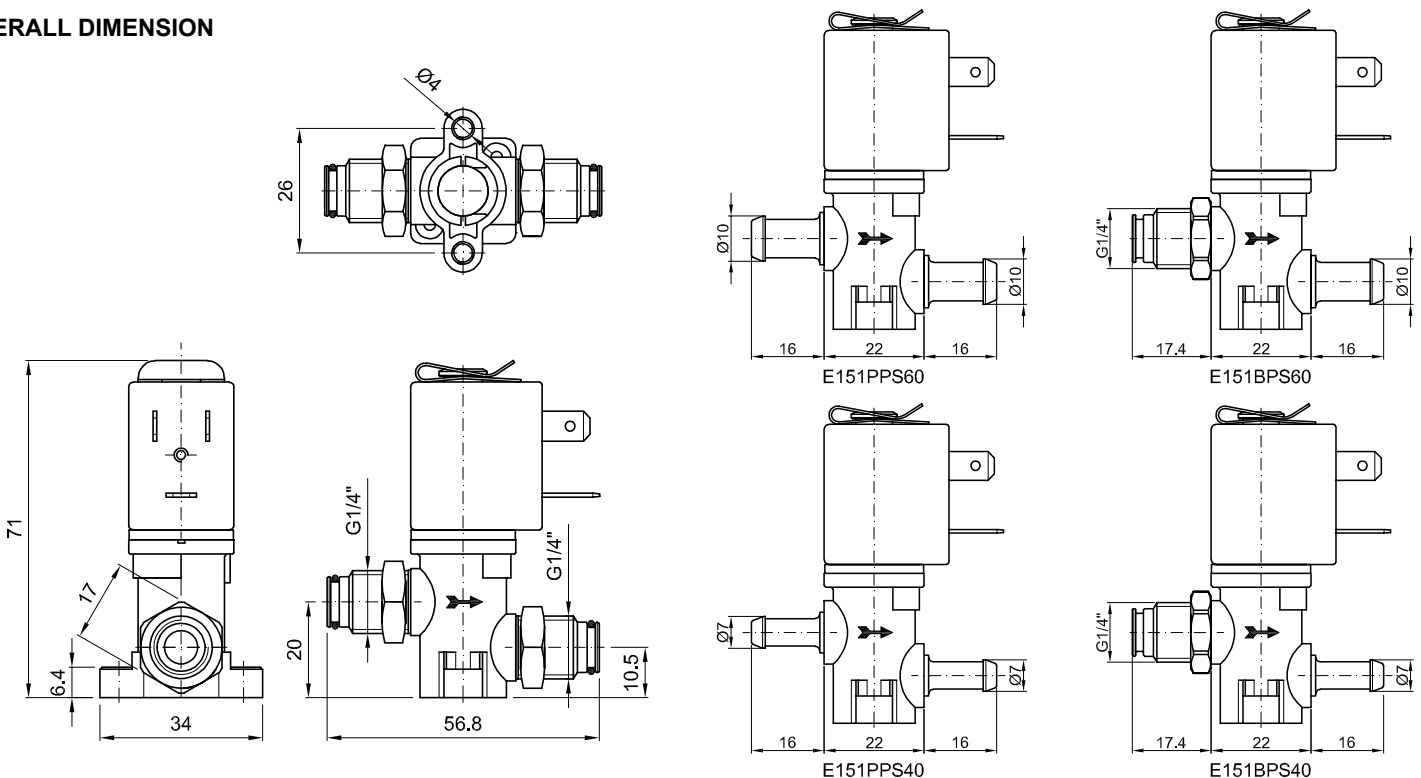



**DESCRIPTION**

Solenoid valve 2 way normally closed  
 direct acting with dry armature.  
 No metal parts in contact with the media.

**CONSTRUCTION**

Body	Acetal copolymer
Armature tube	Stainless steel
Plunger and core	Stainless steel
Springs	Stainless steel
Seal material	SILICONE



**2**

**FEATURES**

Maximum allowable pressure 1.5bar  
 Maximum fluid viscosity 25cSt (mm<sup>2</sup>/s)  
 Ambient temperature: with class F coil -10°C +55°C  
 with class H coil -10°C +80°C  
 Mounting position with vertical coil above

**OPTIONS:** c us certified coils

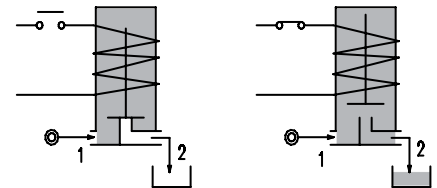
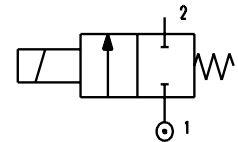

CODE ②	Connection G ISO 228	Orifice mm	Kv m <sup>3</sup> /h	Differential pressure bar		Nominal power			Coil		Seal ①	Temp. range °C	
				Inlet	Outlet	AC Inrush	VA Holding	DC Watt	Series	Width			
<b>Version with closed vent</b>												SILICONE=S	<+95°C
E160SS10/1/...	1/2"	10	1.7	0.5	0.1	20	15	10	2	30			
<b>Version with open vent</b>													
E160SS10///...	1/2"	10	1.7	0.5	0.1	20	15	10	2	30			

② Coil

Example: E160SS10/1/20E Closed vent - Coil 230V 50/60Hz

COILS	Alternating Current 50/60Hz Volt							Direct Current Volt			Electrical connection	Connectors
	12	24	48	110	220 230	240	380	12	24	48		
Series 2 Width 30 Code ②	20A	20B	20C	20D	20E	20F	20G	200	201	202	DIN 43650A	PG9 code 10349000

**DESCRIPTION**  
 Insulation class  
 Series 2 =F Series 5=H  
 Voltage tolerance  
 AC +15% -10%  
 DC ± 10%  
 Protection class  
 IP65 with connector fitted  
 IP00 without connector  
 Continuous service ED100%

**OPTIONS**  
 Class H insulation (series 2)  
 Cable attached  
 Special coil voltage  
 Special coil powers  
 cULus certified coils

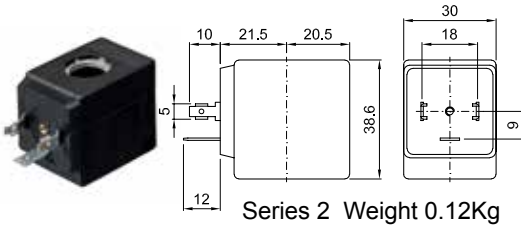

### SPARE PARTS LIST

1. Coil fixing nut
2. Coil
3. Diaphragm

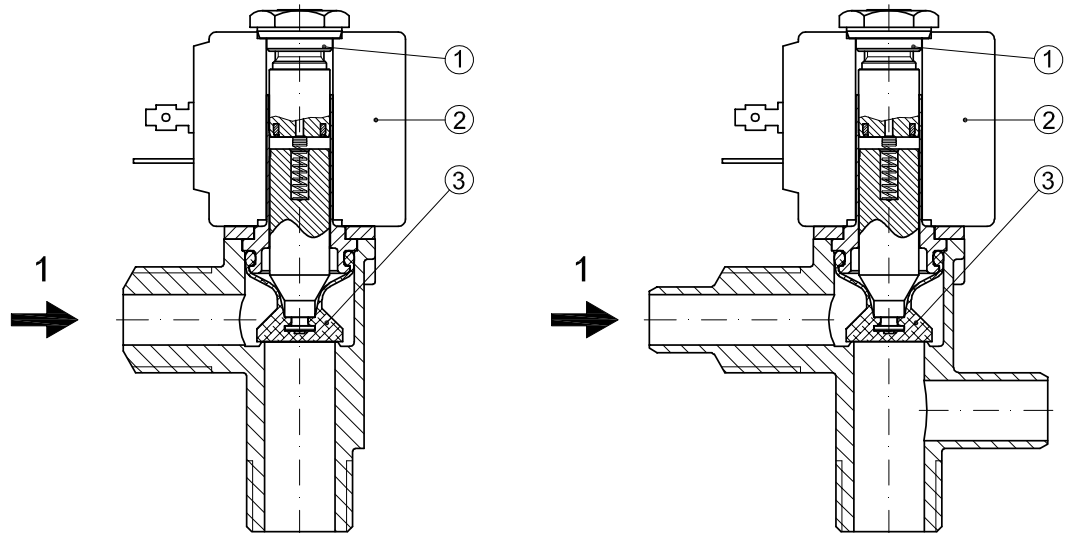

**E160SS10/1/...**  
Version with closed vent

**E160SS10///...**  
Version with open vent

### OVERALL DIMENSION

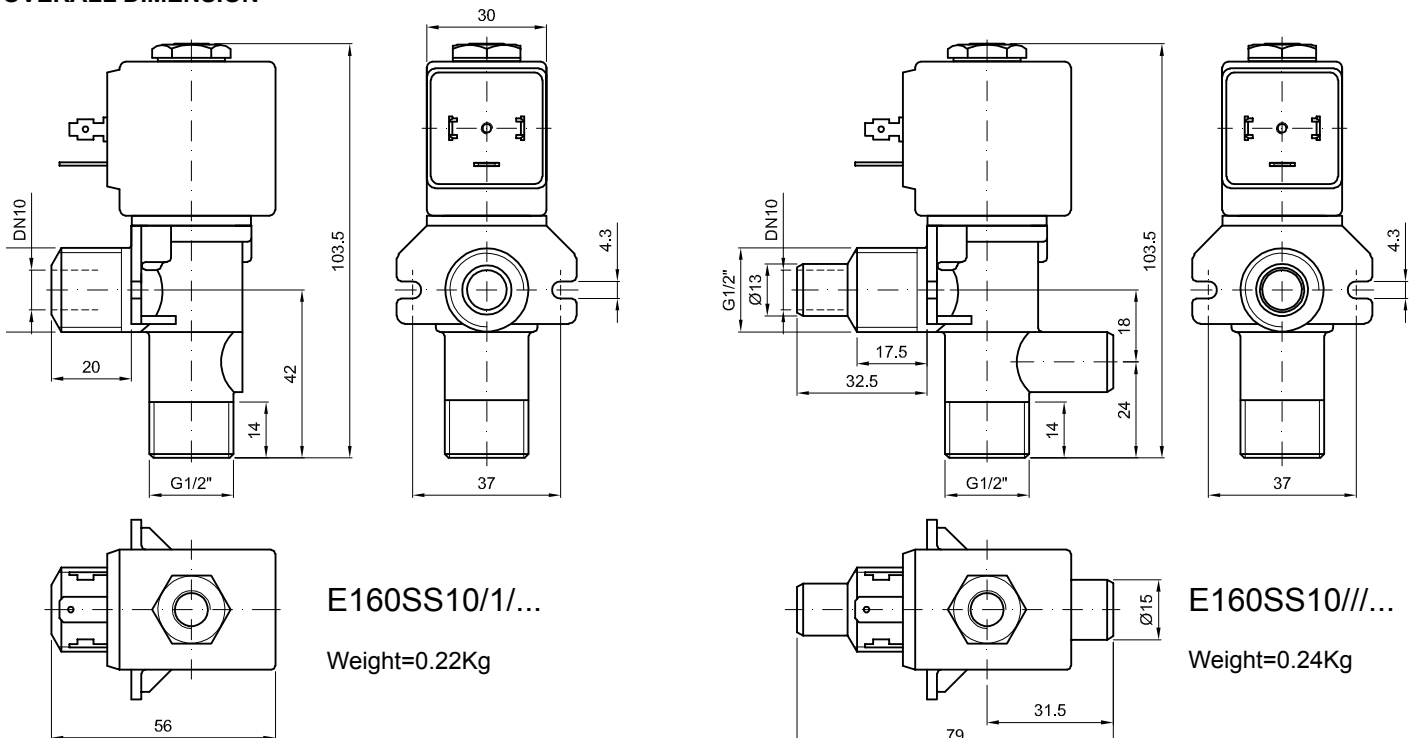

**E160SS10/1/...**  
Weight=0.22Kg

**E160SS10///...**  
Weight=0.24Kg

**DESCRIPTION**

Solenoid valve 2 way normally closed  
 direct acting with dry armature.  
 No metal parts in contact with the media.

**CONSTRUCTION**

Body	Acetal copolymer
Armature tube	Stainless steel
Plunger and core	Stainless steel
Springs	Stainless steel
Seal material	SILICONE



**2**

**FEATURES**

Maximum allowable pressure 2bar  
 Maximum fluid viscosity 25cSt (mm<sup>2</sup>/s)  
 Ambient temperature: with class F coil -10°C +55°C  
 with class H coil -10°C +80°C  
 Mounting position with vertical coil above

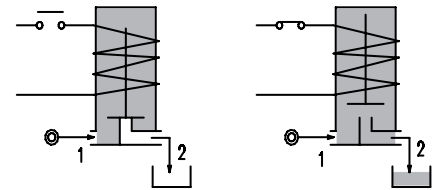
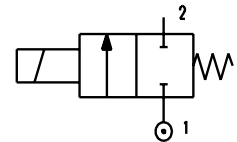

**OPTIONS:** c us certified coils

CODE ②	Connection	Orifice mm	Kv m <sup>3</sup> /h	Differential pressure bar			Nominal power			Coil		Seal ①	Temp. range °C
				Min	Max		AC Inrush	VA Holding	DC Watt	Series	Width		
					AC	DC							
E161PS8///...	Hosetail DN8	8	1.1	0	0.15	0.15	20	15	10	2	30	SILICONE=S	<+95°C
E161PS8/1/...	Hosetail DN8	8	1.1	0	0.5	0.5	40	30	27	5	36		

**For use with VACUUM - feeds from 2 to 1**

CODE ②	Connection	Orifice mm	Kv m <sup>3</sup> /h	Differential pressure bar			Nominal power			Coil		Seal ①	Temp. range °C
				Min	Max		AC Inrush	VA Holding	DC Watt	Series	Width		
					AC	DC							
E161PS8/V/...	Hosetail DN8	8	1.1	0	-0.9	-0.7	20	15	10	2	30	SILICONE=S	<+95°C
E161PS8/V/...	Hosetail DN8	8	1.1	0	-0.9	-0.9	40	30	27	5	36		

② Coil

Example: E161PS8///20E - Coil 230V 50/60Hz

COILS	Alternating Current 50/60Hz Volt							Direct Current Volt			Electrical connection	Connectors
	12	24	48	110	220 230	240	380	12	24	48		
Series 2 Width 30 Code ②	20A	20B	20C	20D	20E	20F	20G	200	201	202	DIN 43650A	PG9 code 10349000
Series 5 Width 36 Code ②	52A	52B	52C	52D	52E	52F	52G	520	521	522	DIN 43650A	PG11 code 10349001

**DESCRIPTION**  
 Insulation class  
 Series 2 =F Series 5=H  
 Voltage tolerance  
 AC +15% -10%  
 DC ± 10%  
 Protection class  
 IP65 with connector fitted  
 IP00 without connector  
 Continuous service ED100%

**OPTIONS**  
 Class H insulation (series 2)  
 Cable attached  
 Special coil voltage  
 Special coil powers  
 us certified coils

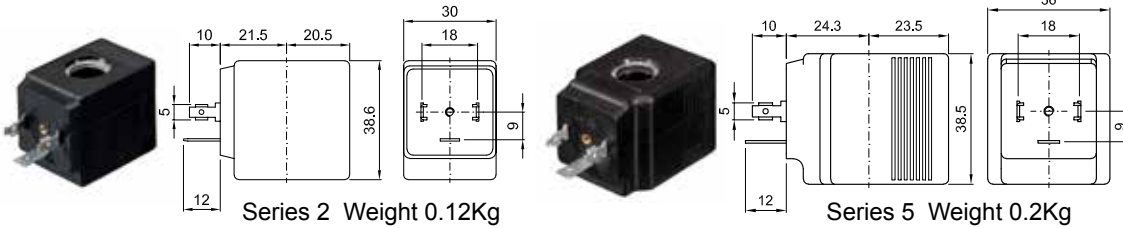

### SPARE PARTS LIST

1. Coil fixing nut
2. Coil
3. Diaphragm

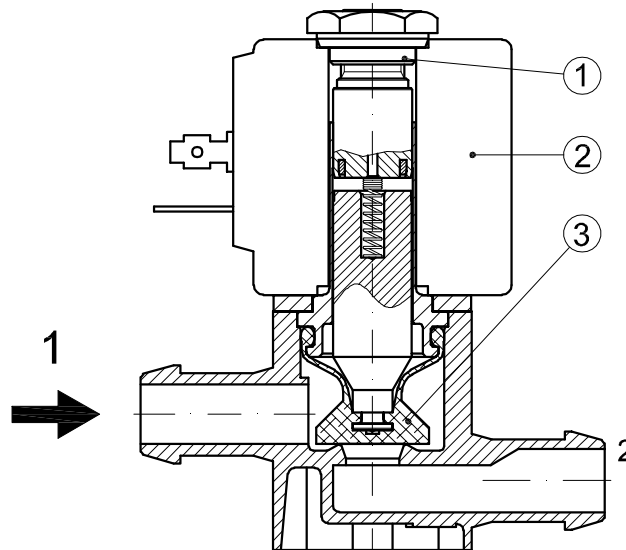

### OVERALL DIMENSION

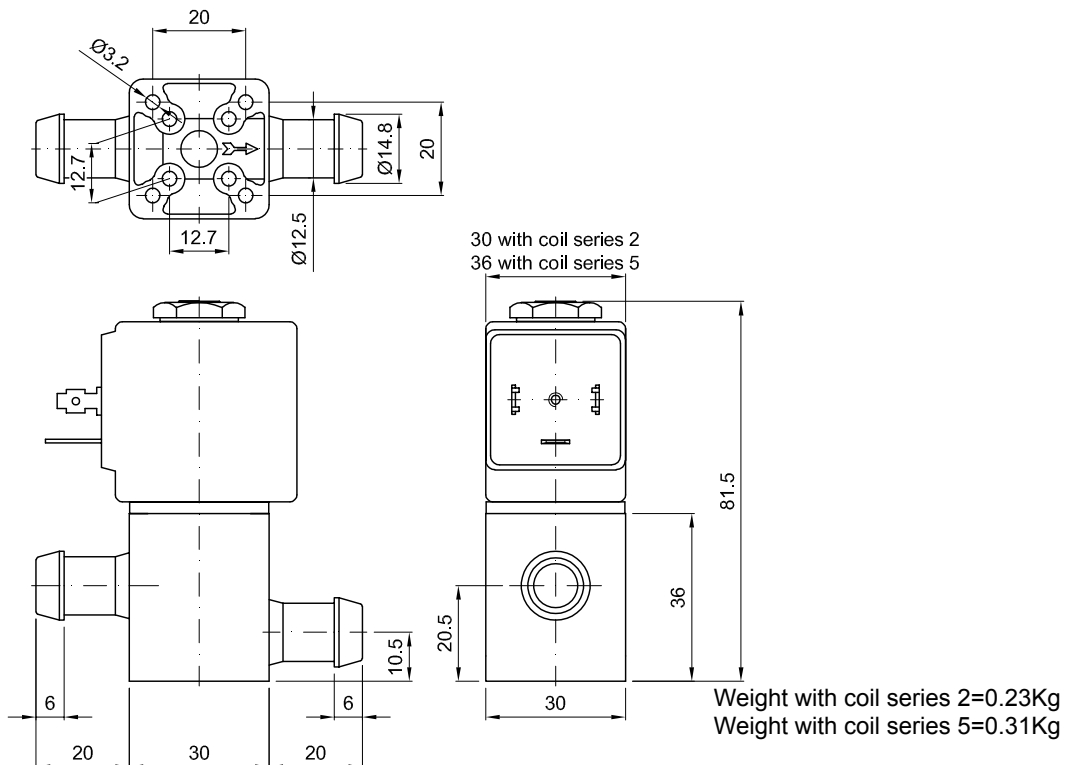

**DESCRIPTION**

Solenoid valve 2 way normally open  
direct acting poppet type

**CONSTRUCTION**

Body	Brass
Armature tube	Stainless steel
Plunger and core	Stainless steel
Springs	Stainless steel
Seal material	NBR - FPM - EPDM



**2**

**FEATURES**

Maximum allowable pressure 50bar  
 Maximum fluid viscosity 25cSt (mm<sup>2</sup>/s)  
 Ambient temperature: with class F coil -10°C +55°C  
 with class H coil -10°C +80°C  
 Universal mounting position

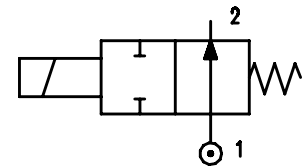

**OPTIONS:** Electroless nickel plating  
 c us certified coils

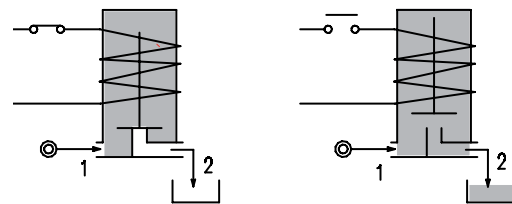

CODE ① ②	Connection G ISO 228	Orifice mm	Kv m <sup>3</sup> /h	Differential pressure bar			Nominal power			Coil		Temp. range °C	
				Min	Max		AC Inrush	VA Holding	DC Watt	Series	Width		Seal ①
					AC	DC							
E203A...20///...	1/8"	2	0.1	0	16	16	20	15	10	2	30	NBR=B	-10 +90
E203A...25///...		2.5	0.14	0	13	13						EPDM=E	-10 +140
E203A...29///...		2.9	0.17	0	10	10						FPM=V	-10 +140

- ① Seal
- ② Coil

Example: E203AV25///20E FPM seal  
 Coil 230V 50/60Hz5bar with EPDM seals

COILS	Alternating Current 50/60Hz Volt							Direct Current Volt			Electrical connection	Connectors
	12	24	48	110	220 230	240	380	12	24	48		
Series 2 Width 30 Code ②	20A	20B	20C	20D	20E	20F	20G	200	201	202	DIN 43650A	PG9 code 10349000

**DESCRIPTION**  
 Class F insulation  
 Voltage tolerance  
 AC +15% -10%  
 DC ± 10%  
 Protection class  
 IP65 with connector fitted  
 IP00 without connector  
 Continuous service ED100%

**OPTIONS**  
 Class H insulation  
 Cable attached  
 Special coil voltage  
 Special coil powers  
 US certified coils

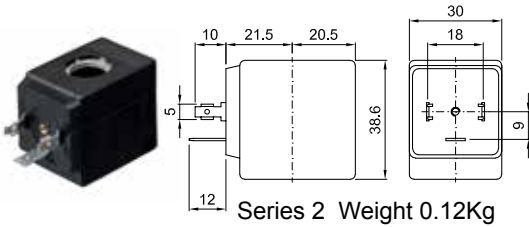

### SPARE PARTS LIST

1. Coil fixing nut
2. Coil
3. Plunger
4. Armature tube with core

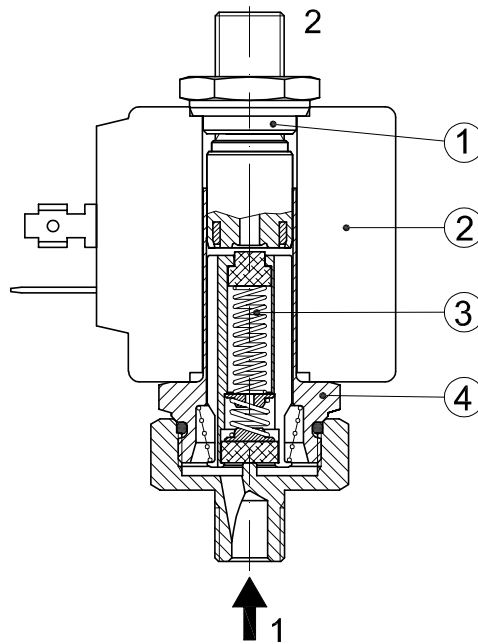

### OVERALL DIMENSION

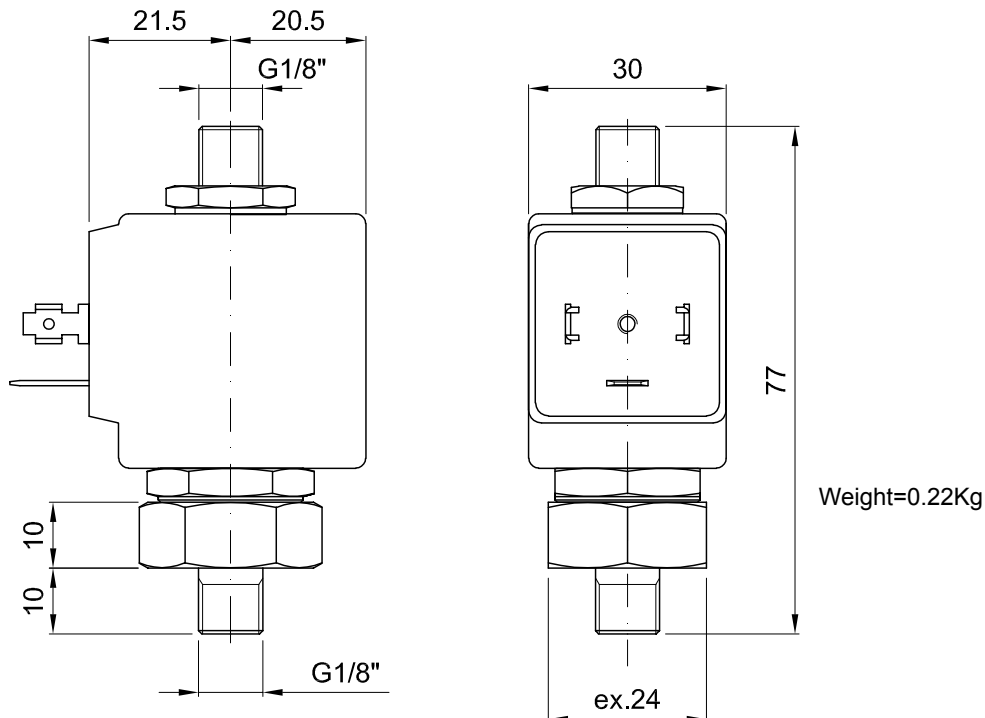

**DESCRIPTION**

Solenoid valve 2 way normally open  
direct acting poppet type

**CONSTRUCTION**

Body	Brass
Armature tube	Brass
Plunger and core	Stainless steel
Springs	Stainless steel
Seal material	NBR - FPM - EPDM



**2**

**FEATURES**

Maximum allowable pressure: max working pressure +10%  
 Maximum fluid viscosity 25cSt (mm<sup>2</sup>/s)  
 Ambient temperature: with class F coil -10°C +55°C  
 with class H coil -10°C +80°C  
 Universal mounting position

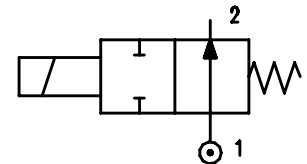

**OPTIONS:** Stainless steel armature tube  
 Electroless nickel plating  
 Explosion proof coil according to ATEX - EExmII Series 7  
 User port with hosetail connection  
 cULus certified coils

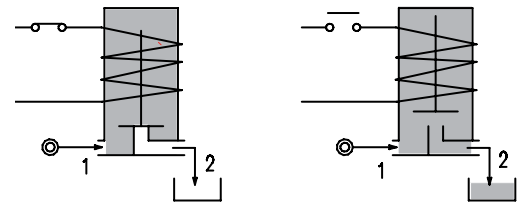

CODE ① ②	Connection G ISO 228	Orifice mm	Kv m <sup>3</sup> /h	Differential pressure bar			Nominal power			Coil		Seal ①	Temp. range °C
				Min	Max AC DC		AC Inrush	VA Holding	DC Watt	Series	Width		
<b>User port with M5 connection</b>													
E204A...15///...	1/8"	1.5	0.06	0	16	16	12	8	6.5	3	22	NBR=B	-10 +90
E204A...17///...		1.7	0.08	0	12	12							
<b>User port with hosetail connection</b>													
E204A...15/1/...	1/8"	1.5	0.06	0	16	16	12	8	6.5	3	22	EPDM=E	<+140
E204A...17/1/...		1.7	0.08	0	12	12							
<b>User port with hosetail connection and relief valve</b>													
E204A...15/3/...	1/8"	1.5	0.06	0	16	16	12	8	6.5	3	22	FPM=V	-10 +140
E204A...17/3/...		1.7	0.08	0	12	12							

- ① Seal
- ② Coil

Example: E204AB17///301 NBR seal  
Coil 24V DC

COILS	Alternating Current 50/60Hz Volt							Direct Current Volt			Electrical connection	Connectors
	12	24	48	110	220 230	240	380	12	24	48		
Series 3 Width 22 Code ②	30A	30B	30C	30D	30E	30F	30G	300	301	302	DIN 46244	PG9 code 10348000

**DESCRIPTION**  
 Class F insulation  
 Voltage tolerance  
 AC +15% -10%  
 DC ± 10%  
 Protection class  
 IP65 with connector fitted  
 IP00 without connector  
 Continuous service ED100%

**OPTIONS**  
 Class H insulation  
 Cable attached  
 Special coil voltage  
 Special coil powers  
 CE certified coils

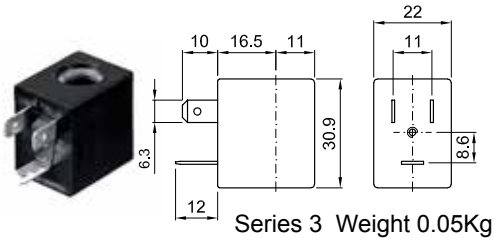

### SPARE PARTS LIST

1. Coil fixing nut
2. Coil
3. Plunger
4. Armature tube with core

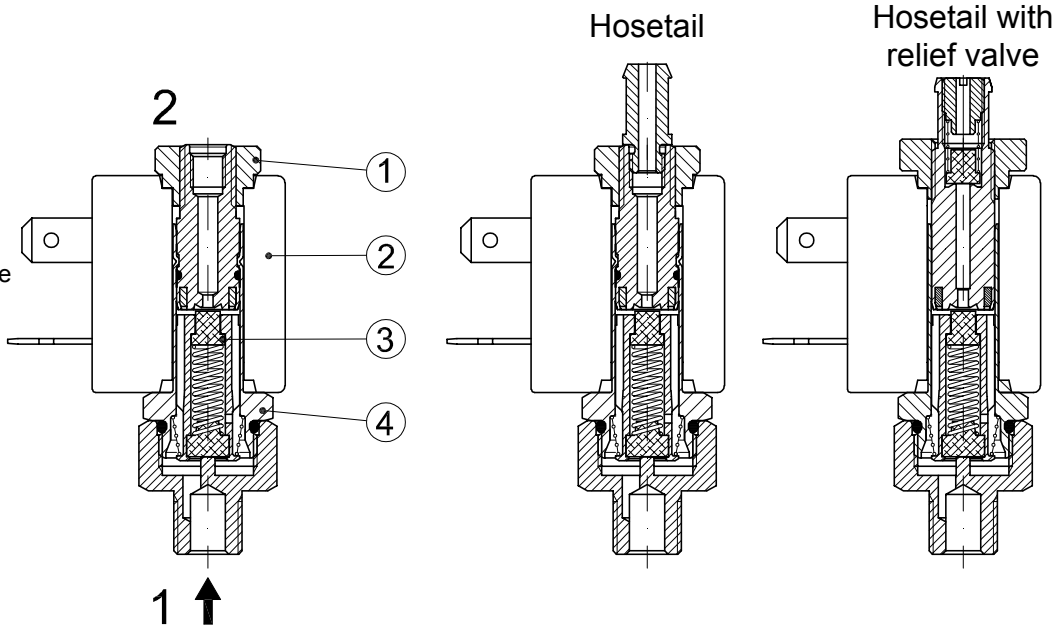

### OVERALL DIMENSION

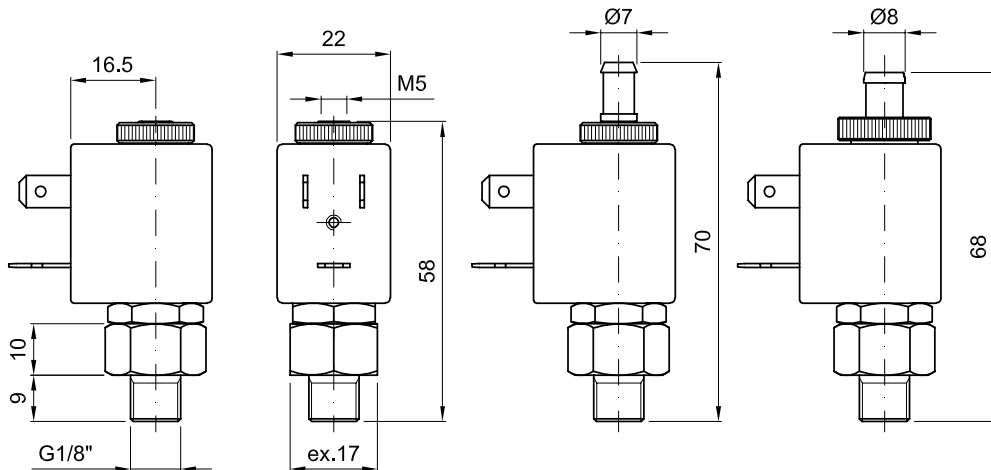

Weight with coil series 3=0.13Kg  
 Weight with coil series 4=0.18Kg



**DESCRIPTION**

Solenoid valve 2 way normally open  
direct acting poppet type

**CONSTRUCTION**

Body	Brass
Armature tube	Brass
Plunger and core	Stainless steel
Springs	Stainless steel
Seal material	NBR - FPM - EPDM



**2**

**FEATURES**

Maximum allowable pressure 50bar\*  
 Maximum fluid viscosity 25cSt (mm<sup>2</sup>/s)  
 Ambient temperature: with class F coil -10°C +55°C  
 with class H coil -10°C +80°C  
 Universal mounting position

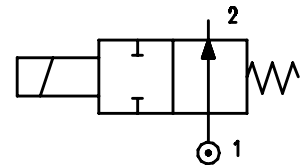

**OPTIONS:** Stainless steel armature tube  
 Electroless nickel plating  
 Series 7 explosion proof coil according to ATEX - EExmII  
 US certified coils

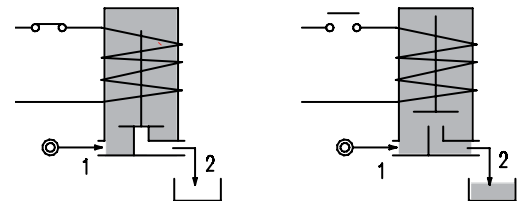

CODE ① ②	Connection G ISO 228	Orifice mm	Kv m <sup>3</sup> /h	Differential pressure bar			Nominal power			Coil		Temp. range °C	
				Min	Max		AC Inrush	VA Holding	DC Watt	Series	Width		Seal ①
					AC	DC							
E205A...12///...	1/8"	1.2	0.04	0	19	19	12	8	6.5	3	22	NBR=B	-10 +90
E205A...15///...		1.5	0.06	0	14	14						EPDM=E	-10 +140
E205A...20///...		2	0.09	0	8	8						FPM=V	-10 +140
E205A...25///...		2.5	0.14	0	4.5	4.5							
E205A...31///...		3.1	0.19	0	2.5	2.5							

① Seal Example: E205AB20///30B NBR seal  
 ② Coil Coil 24V 50/60Hz

\* REMARK: The maximum allowable pressure PS for steam is 2,5bar (gauge pressure)

COILS	Alternating Current 50/60Hz Volt							Direct Current Volt			Electrical connection	Connectors
	12	24	48	110	220 230	240	380	12	24	48		
Series 3 Width 22 Code ②	30A	30B	30C	30D	30E	30F	30G	300	301	302	DIN 46244	PG9 code 10348000

**DESCRIPTION**  
 Class F insulation  
 Voltage tolerance  
 AC +15% -10%  
 DC ± 10%  
 Protection class  
 IP65 with connector fitted  
 IP00 without connector  
 Continuous service ED100%

**OPTIONS**  
 Class H insulation  
 Cable attached  
 Special coil voltage  
 Special coil powers  
 cULus certified coils

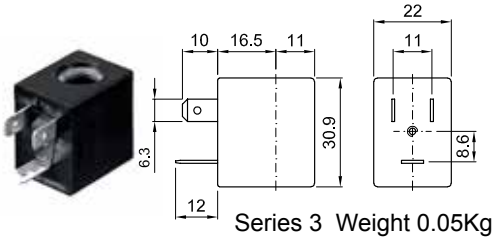

### SPARE PARTS LIST

1. Coil fixing nut
2. Coil
3. Seal assembly
4. Armature tube with core

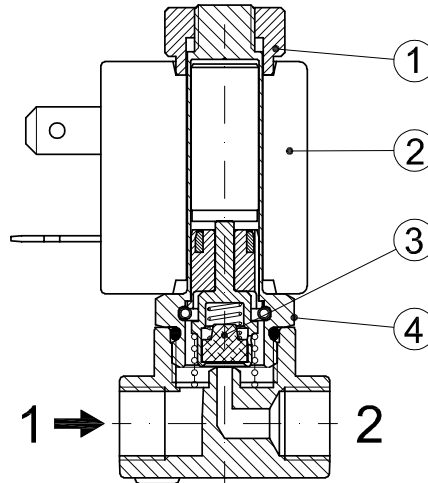

### OVERALL DIMENSION

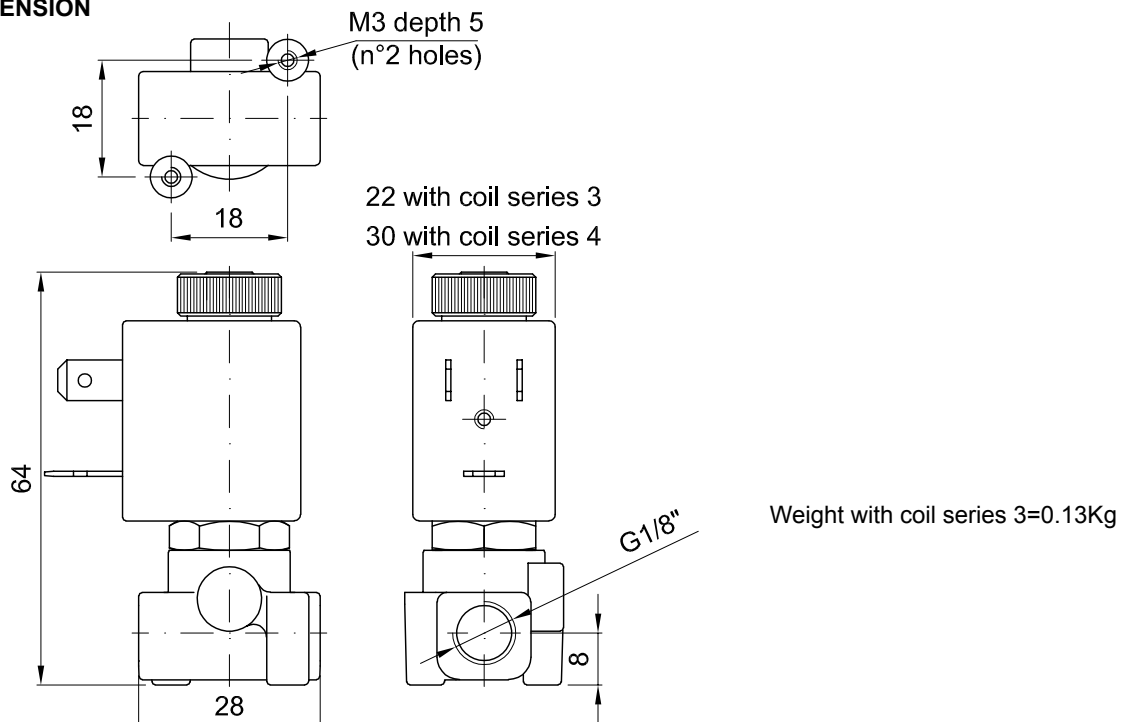

**DESCRIPTION**

Solenoid valve 2 way normally open  
direct acting poppet type

**CONSTRUCTION**

Body	Brass
Armature tube	Brass
Plunger and core	Stainless steel
Springs	Stainless steel
Seal material	NBR - FPM - EPDM



**2**

**FEATURES**

Maximum allowable pressure 50bar\*  
 Maximum fluid viscosity 25cSt (mm<sup>2</sup>/s)  
 Ambient temperature: with class F coil -10°C +55°C  
 with class H coil -10°C +80°C  
 Universal mounting position

**OPTIONS:** Stainless steel armature tube  
 Electroless nickel plating  
 cULus certified coils

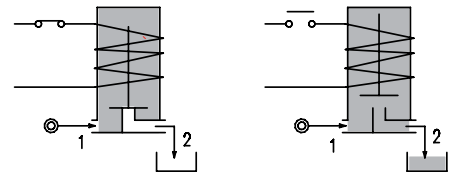
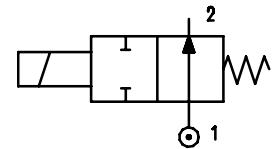

CODE ① ②	Connection G ISO 228	Orifice mm	Kv m <sup>3</sup> /h	Differential pressure bar			Nominal power			Coil		Seal ①	Temp. range °C
				Min	Max		AC Inrush	VA Holding	DC Watt	Series	Width		
					AC	DC							
E206A...15///...	1/8"	1.5	0.07	0	23	-	20	15	-	2	30	NBR=B	-10 +90
E206A...20///...		2	0.1	0	17	-							
E206A...25///...		2.5	0.15	0	12	-							
E206A...35///...		3.5	0.32	0	7	-							
E206A...15///...	1/8"	1.5	0.07	0	23	23	40	30	27	5	36	EPDM=E	-10 +140
E206A...20///...		2	0.1	0	17	17							
E206A...25///...		2.5	0.15	0	12	12							
E206A...35///...		3.5	0.32	0	7	7							
D206A...15/3/...	1/8"	1.5	0.07	0	-	18	-	-	10	2	30	FPM=V	-10 +140
D206A...20/3/...		2	0.1	0	-	11							
D206A...25/3/...		2.5	0.15	0	-	7							
D206A...35/3/...		3.5	0.32	0	-	4							

① Seal Example: E206BB20///20E NBR seal  
 ② Coil Coil 230V 50/60Hz

\* REMARK: The maximum allowable pressure PS for steam is 2,5bar (gauge pressure)

COILS	Alternating Current 50/60Hz Volt							Direct Current Volt			Electrical connection	Connectors
	12	24	48	110	220 230	240	380	12	24	48		
Series 2 Width 30 Code ②	20A	20B	20C	20D	20E	20F	20G	200	201	202	DIN 43650A	PG9 code 10349000
Series 5 Width 36 Code ②	52A	52B	52C	52D	52E	52F	52G	520	521	522	DIN 43650A	PG11 code 10349001

**DESCRIPTION**  
 Insulation class  
 Series 2 =F Series 5=H  
 Voltage tolerance  
 AC +15% -10%  
 DC ± 10%  
 Protection class  
 IP65 with connector fitted  
 IP00 without connector  
 Continuous service ED100%

**OPTIONS**  
 Class H insulation (series 2)  
 Cable attached  
 Special coil voltage  
 Special coil powers  
 cULus certified coils

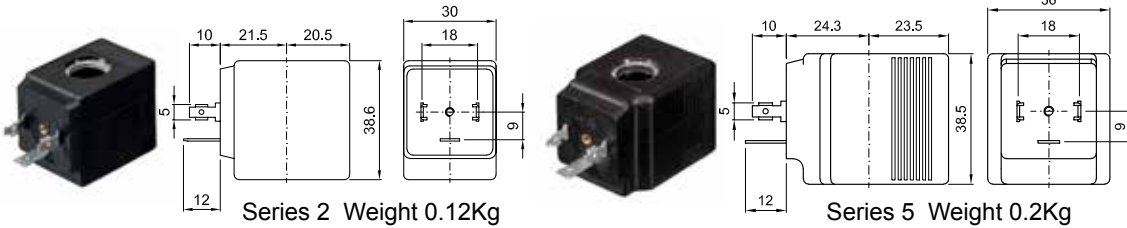

### SPARE PARTS LIST

1. Coil fixing nut
2. Coil
3. Seal assembly
4. Armature tube with core

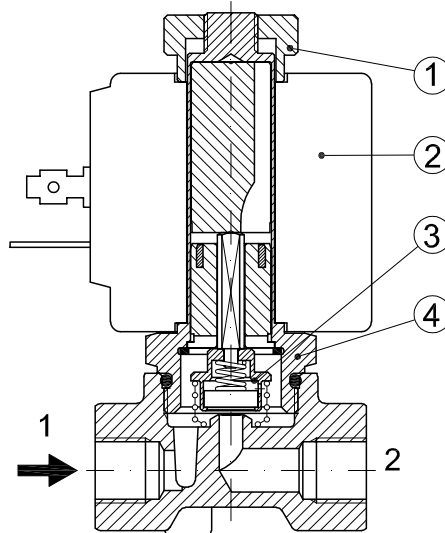

### OVERALL DIMENSION

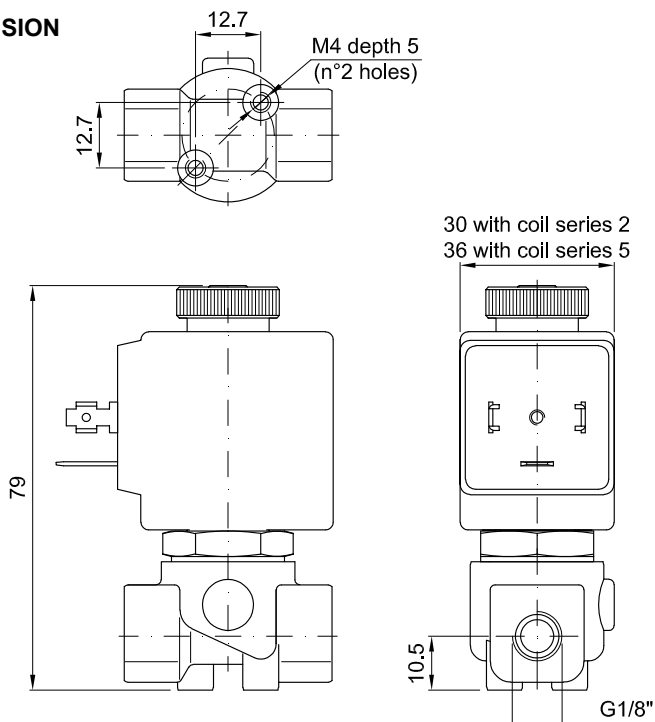

Weight with coil series 2=0.30Kg  
 Weight with coil series 5=0.38Kg

**DESCRIPTION**

Solenoid valve 2 way normally open  
direct acting poppet type

**CONSTRUCTION**

Body	Brass
Armature tube	Brass
Plunger and core	Stainless steel
Springs	Stainless steel
Seal material	NBR - FPM - EPDM



**2**

**FEATURES**

Maximum allowable pressure 50bar\*  
 Maximum fluid viscosity 25cSt (mm<sup>2</sup>/s)  
 Ambient temperature: with class F coil -10°C +55°C  
 with class H coil -10°C +80°C  
 Universal mounting position

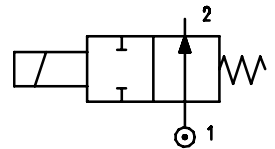

**OPTIONS:** Stainless steel armature tube  
 Electroless nickel plating  
 cULus certified coils

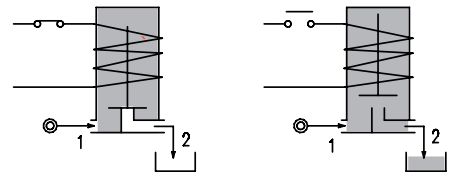

CODE ① ②	Connection G ISO 228	Orifice mm	Kv m <sup>3</sup> /h	Differential pressure bar			Nominal power			Coil		Seal ①	Temp. range °C
				Min	Max		AC Inrush	VA Holding	DC Watt	Series	Width		
					AC	DC							
E206B...15///...	1/4"	1.5	0.07	0	23	-	20	15	-	2	30	NBR=B EPDM=E FPM=V	-10 +90 -10 +140 -10 +140
E206B...20///...		2	0.1	0	17	-							
E206B...25///...		2.5	0.15	0	12	-							
E206B...35///...		3.5	0.32	0	7	-							
E206B...45///...		4.5	0.41	0	4.5	-							
E206B...52///...		5.2	0.47	0	3	-							
E206B...15///...	1/4"	1.5	0.07	0	23	23	40	30	27	5	36		
E206B...20///...		2	0.1	0	17	17							
E206B...25///...		2.5	0.15	0	12	12							
E206B...35///...		3.5	0.32	0	7	7							
E206B...45///...		4.5	0.41	0	4.5	4.5							
E206B...52///...		5.2	0.47	0	3	3							
E206B...64///...	6.4	0.64	0	3.5	3.5								
D206B...15/3/...	1/4"	1.5	0.07	0	-	18	-	-	10	2	30		
D206B...20/3/...		2	0.1	0	-	11							
D206B...25/3/...		2.5	0.15	0	-	7							
D206B...35/3/...		3.5	0.32	0	-	4							
D206B...45/3/...		4.5	0.41	0	-	3							
D206B...52/3/...		5.2	0.47	0	-	2.2							

① Seal Example: E206BB35///20E NBR seal  
 ② Coil Coil 230V 50/60Hz

\* REMARK: The maximum allowable pressure PS for steam is 2,5bar (gauge pressure)

COILS	Alternating Current 50/60Hz Volt							Direct Current Volt			Electrical connection	Connectors
	12	24	48	110	220 230	240	380	12	24	48		
Series 2 Width 30 Code ②	20A	20B	20C	20D	20E	20F	20G	200	201	202	DIN 43650A	PG9 code 10349000
Series 5 Width 36 Code ②	52A	52B	52C	52D	52E	52F	52G	520	521	522	DIN 43650A	PG11 code 10349001

**DESCRIPTION**  
 Insulation class  
 Series 2 =F Series 5=H  
 Voltage tolerance  
 AC +15% -10%  
 DC ± 10%  
 Protection class  
 IP65 with connector fitted  
 IP00 without connector  
 Continuous service ED100%

**OPTIONS**  
 Class H insulation (series 2)  
 Cable attached  
 Special coil voltage  
 Special coil powers  
 cULus certified coils

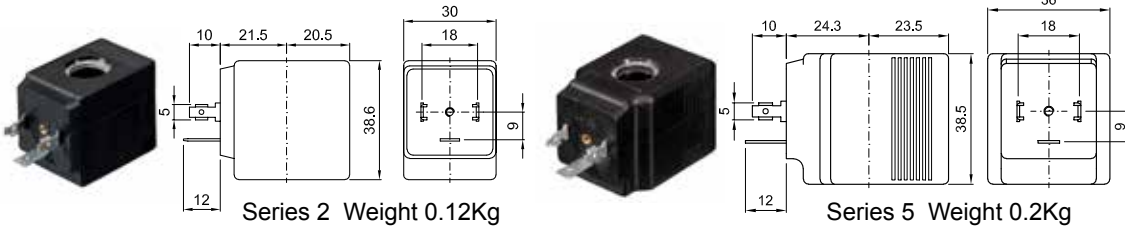

### SPARE PARTS LIST

1. Coil fixing nut
2. Coil
3. Seal assembly
4. Armature tube with core

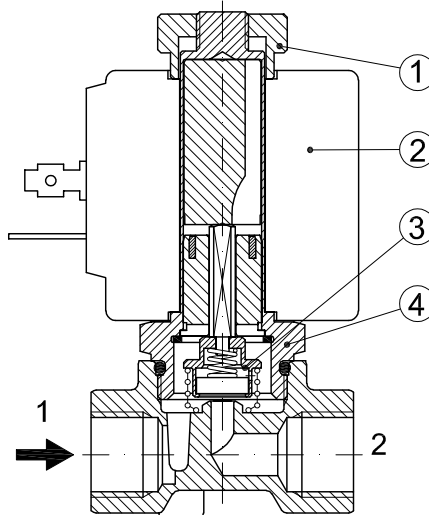

### OVERALL DIMENSION

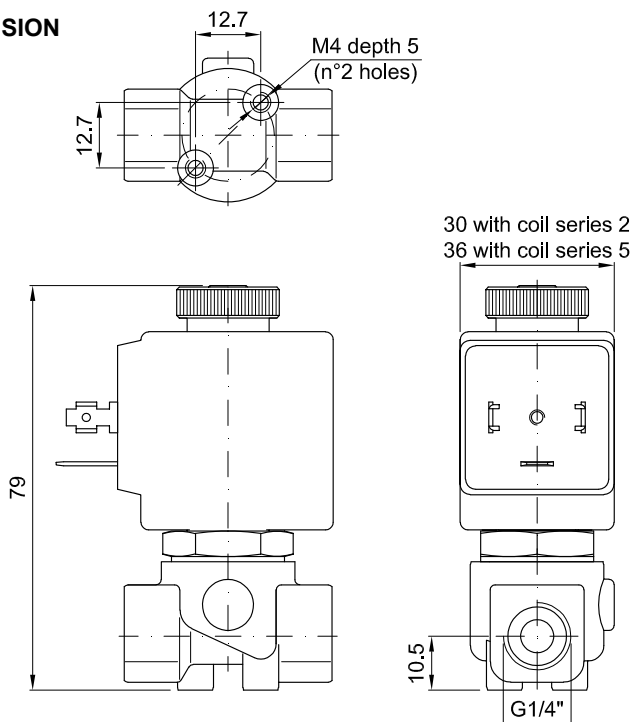

Weight with coil series 2=0.30Kg  
 Weight with coil series 5=0.38Kg

**DESCRIPTION**

Solenoid valve 2 way normally open  
direct acting poppet type

**CONSTRUCTION**

Body	Brass
Armature tube	Brass
Plunger and core	Stainless steel
Springs	Stainless steel
Seal material	NBR - FPM - EPDM



**2**

**FEATURES**

Maximum allowable pressure 50bar\*  
 Maximum fluid viscosity 25cSt (mm<sup>2</sup>/s)  
 Ambient temperature: with class F coil -10°C +55°C  
 with class H coil -10°C +80°C  
 Universal mounting position

**OPTIONS:** Stainless steel armature tube  
 Electroless nickel plating  
 cULus certified coils

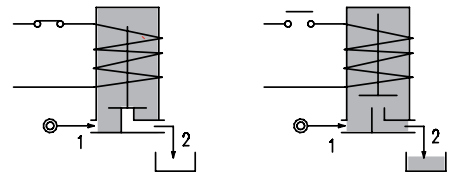
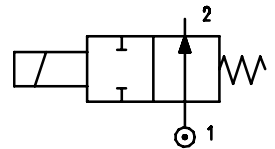

CODE ① ②	Connection G ISO 228	Orifice mm	Kv m <sup>3</sup> /h	Differential pressure bar			Nominal power			Coil		Seal ①	Temp. range °C		
				Min	Max AC DC		AC Inrush	VA Holding	DC Watt	Series	Width				
E206C...30///...	3/8"	3	0.25	0	9	-	20	15	-	2	30	NBR=B EPDM=E FPM=V	-10 +90		
E206C...35///...		3.5	0.32	0	7	-									
E206C...40///...		4	0.36	0	5.5	-									
E206C...45///...		4.5	0.41	0	4.5	-									
E206C...52///...		5.2	0.47	0	3	-									
E206C...30///...	3/8"	3	0.25	0	9	9	40	30	27	5	36			NBR=B EPDM=E FPM=V	-10 +90
E206C...35///...		3.5	0.32	0	7	7									
E206C...40///...		4	0.36	0	5.5	5.5									
E206C...45///...		4.5	0.41	0	4.5	4.5									
E206C...52///...		5.2	0.47	0	3	3									
E206C...64///...	6.4	0.64	0	3.5	3.5										
D206C...30/3/...	3/8"	3	0.25	0	-	6.5	-	-	10	2	30	NBR=B EPDM=E FPM=V	-10 +90		
D206C...35/3/...		3.5	0.32	0	-	4									
D206C...40/3/...		4	0.36	0	-	3.5									
D206C...45/3/...		4.5	0.41	0	-	3									
D206C...52/3/...		5.2	0.47	0	-	2.2									

① Seal Example: E206CB45///20B NBR seal  
 ② Coil Coil 24V 50/60Hz

\* REMARK: The maximum allowable pressure PS for steam is 2,5bar (gauge pressure)

COILS	Alternating Current 50/60Hz Volt							Direct Current Volt			Electrical connection	Connectors
	12	24	48	110	220 230	240	380	12	24	48		
Series 2 Width 30 Code ②	20A	20B	20C	20D	20E	20F	20G	200	201	202	DIN 43650A	PG9 code 10349000
Series 5 Width 36 Code ②	52A	52B	52C	52D	52E	52F	52G	520	521	522	DIN 43650A	PG11 code 10349001

**DESCRIPTION**  
 Insulation class  
 Series 2 =F Series 5=H  
 Voltage tolerance  
 AC +15% -10%  
 DC ± 10%  
 Protection class  
 IP65 with connector fitted  
 IP00 without connector  
 Continuous service ED100%

**OPTIONS**  
 Class H insulation (series 2)  
 Cable attached  
 Special coil voltage  
 Special coil powers  
 us certified coils

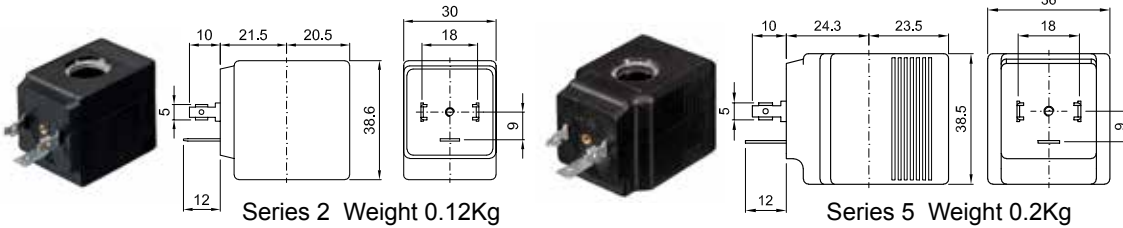

### SPARE PARTS LIST

1. Coil fixing nut
2. Coil
3. Seal assembly
4. Armature tube with core

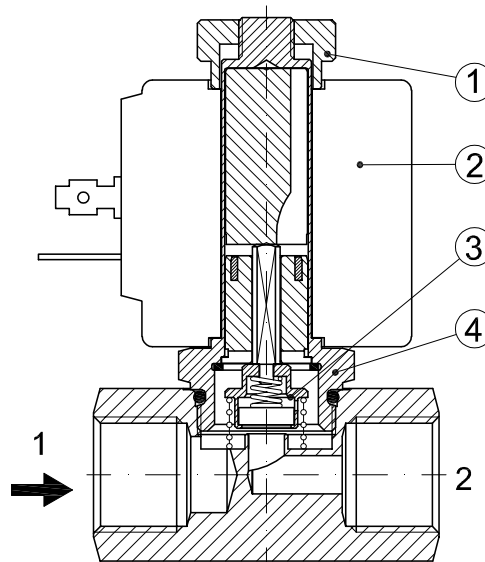

### OVERALL DIMENSION

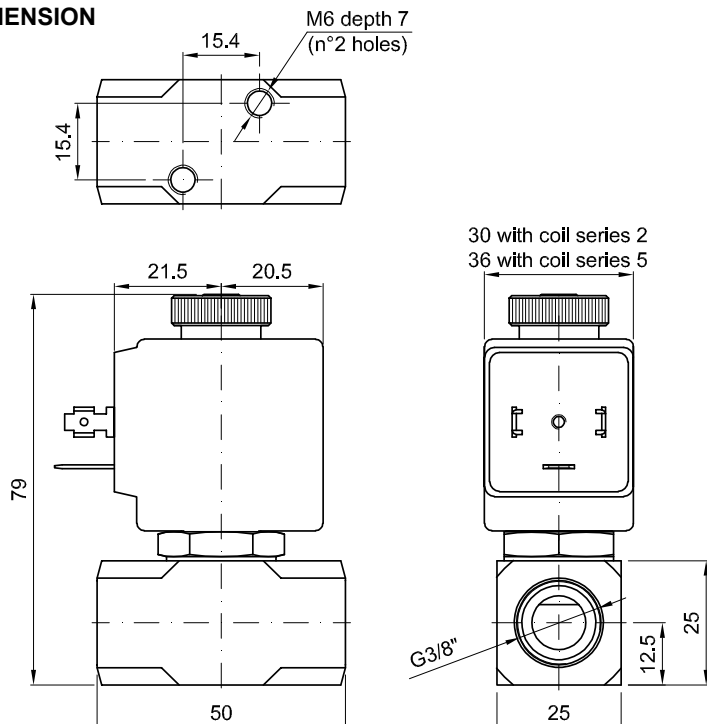

Weight with coil series 2=0.30Kg  
 Weight with coil series 5=0.38Kg



**DESCRIPTION**

Solenoid valve 2 way normally open direct acting poppet type

**CONSTRUCTION**

Body	Brass
Armature tube	Brass
Plunger and core	Stainless steel
Springs	Stainless steel
Seal material	NBR - FPM - EPDM

**FEATURES**

Maximum allowable pressure 50bar\*  
 Maximum fluid viscosity 25cSt (mm<sup>2</sup>/s)  
 Ambient temperature: with class F coil -10°C +55°C  
 with class H coil -10°C +80°C  
 Universal mounting position

**OPTIONS:** Stainless steel armature tube  
 Electroless nickel plating  
 US certified coils



**2**

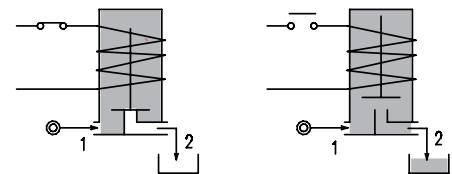
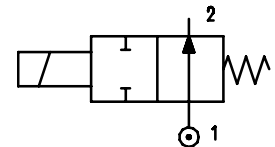

CODE ① ②	Connection G ISO 228	Orifice mm	Kv m <sup>3</sup> /h	Differential pressure bar			Nominal power			Coil		Seal ①	Temp. range °C		
				Min	Max		AC Inrush	VA Holding	DC Watt	Series	Width				
					AC	DC									
E206D...30///...	1/2"	3	0.25	0	9	-	20	15	-	2	30	NBR=B EPDM=E FPM=V	-10 +90		
E206D...35///...		3.5	0.32	0	7	-									
E206D...40///...		4	0.36	0	5.5	-									
E206D...45///...		4.5	0.41	0	4.5	-									
E206D...52///...		5.2	0.47	0	3	-									
E206D...30///...	1/2"	3	0.25	0	9	9	40	30	27	5	36			NBR=B EPDM=E FPM=V	-10 +90
E206D...35///...		3.5	0.32	0	7	7									
E206D...40///...		4	0.36	0	5.5	5.5									
E206D...45///...		4.5	0.41	0	4.5	4.5									
E206D...52///...		5.2	0.47	0	3	3									
E206D...64///...		6.4	0.64	0	3.5	3.5									
D206D...30/3/...	1/2"	3	0.25	0	-	6.5	-	-	10	2	30	NBR=B EPDM=E FPM=V	-10 +90		
D206D...35/3/...		3.5	0.32	0	-	4									
D206D...40/3/...		4	0.36	0	-	3.5									
D206D...45/3/...		4.5	0.41	0	-	3									
D206D...52/3/...		5.2	0.47	0	-	2.2									

① Seal  
 ② Coil  
 Example: E206DB45///20B NBR seal  
 Coil 24V 50/60Hz

\* REMARK: The maximum allowable pressure PS for steam is 2,5bar (gauge pressure)

COILS	Alternating Current 50/60Hz Volt							Direct Current Volt			Electrical connection	Connectors
	12	24	48	110	220 230	240	380	12	24	48		
Series 2 Width 30 Code ②	20A	20B	20C	20D	20E	20F	20G	200	201	202	DIN 43650A	PG9 code 10349000
Series 5 Width 36 Code ②	52A	52B	52C	52D	52E	52F	52G	520	521	522	DIN 43650A	PG11 code 10349001

**DESCRIPTION**  
 Insulation class  
 Series 2 =F Series 5=H  
 Voltage tolerance  
 AC +15% -10%  
 DC ± 10%  
 Protection class  
 IP65 with connector fitted  
 IP00 without connector  
 Continuous service ED100%

**OPTIONS**  
 Class H insulation (series 2)  
 Cable attached  
 Special coil voltage  
 Special coil powers  
 cULus certified coils

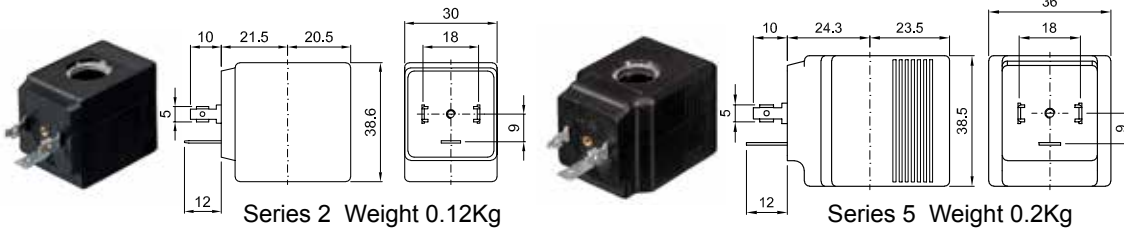

### SPARE PARTS LIST

1. Coil fixing nut
2. Coil
3. Seal assembly
4. Armature tube with core

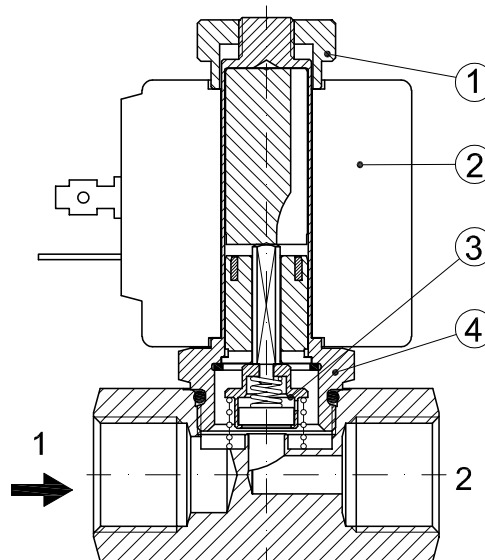

### OVERALL DIMENSION

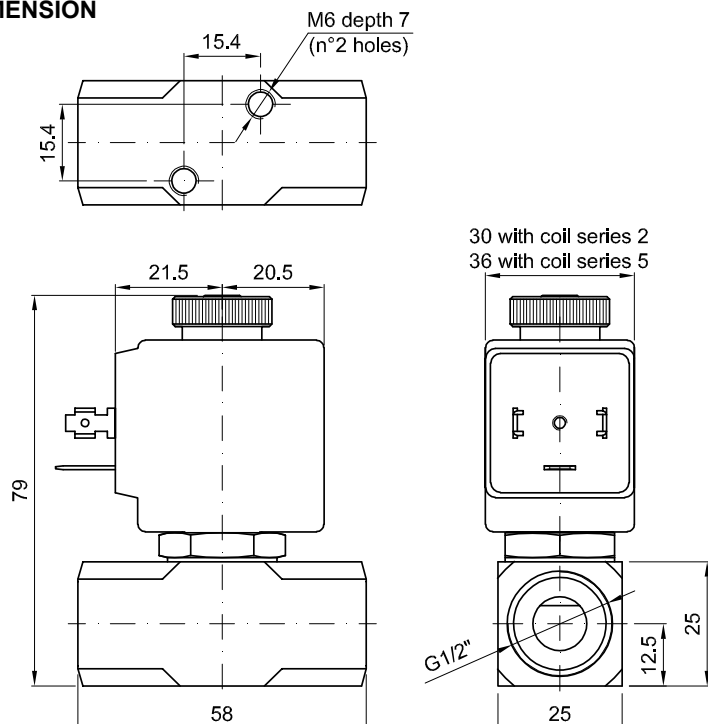

Weight with coil series 2=0.30Kg  
 Weight with coil series 5=0.38Kg

**DESCRIPTION**

Solenoid valve 2 way normally open  
direct acting poppet type

**CONSTRUCTION**

Body	Stainless steel
Armature tube	Stainless steel
Plunger and core	Stainless steel
Springs	Stainless steel
Seal material	NBR - FPM - EPDM



**2**

**FEATURES**

Maximum allowable pressure 50bar\*  
 Maximum fluid viscosity 25cSt (mm<sup>2</sup>/s)  
 Ambient temperature: with class F coil -10°C +55°C  
 with class H coil -10°C +80°C  
 Universal mounting position

**OPTIONS:** Silver shading ring  
 Version for use with industrial oxygen  
 c us certified coils

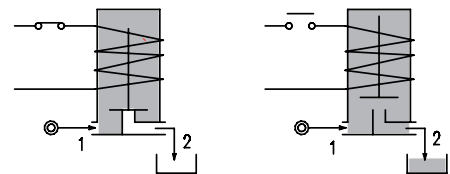
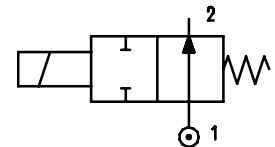

CODE ① ②	Connection G ISO 228	Orifice mm	Kv m <sup>3</sup> /h	Differential pressure bar			Nominal power			Coil		Seal ①	Temp. range °C
				Min	Max		AC Inrush	VA Holding	DC Watt	Series	Width		
					AC	DC							
E210B...20///...	1/4"	2	0.1	0	16	-	20	15	-	2	30	NBR=B	-10 +90
E210B...25///...		2.5	0.15	0	10	-							
E210B...35///...		3.5	0.32	0	7	-							
E210B...45///...		4.5	0.41	0	4.5	-							
E210B...52///...		5.2	0.47	0	3	-							
E210B...20///...	1/4"	2	0.1	0	16	16	40	30	27	5	36	EPDM=E	-10 +140
E210B...25///...		2.5	0.15	0	10	10							
E210B...35///...		3.5	0.32	0	7	7							
E210B...45///...		4.5	0.41	0	4.5	4.5							
E210B...52///...		5.2	0.47	0	3	3							
D210B...20///...	1/4"	2	0.1	0	-	16	-	-	10	2	30	FPM=V	-10 +140
D210B...25///...		2.5	0.15	0	-	10							
D210B...35/3/...		3.5	0.32	0	-	4							
D210B...45/3/...		4.5	0.41	0	-	3							
D210B...52/3/...		5.2	0.47	0	-	2.2							

① Seal Example: E210BB20///201 NBR seal  
 ② Coil Coil 24V DC

\* REMARK: The maximum allowable pressure PS for steam is 2,5bar (gauge pressure)

COILS	Alternating Current 50/60Hz Volt							Direct Current Volt			Electrical connection	Connectors
	12	24	48	110	220 230	240	380	12	24	48		
Series 2 Width 30 Code ②	20A	20B	20C	20D	20E	20F	20G	200	201	202	DIN 43650A	PG9 code 10349000
Series 5 Width 36 Code ②	52A	52B	52C	52D	52E	52F	52G	520	521	522	DIN 43650A	PG11 code 10349001

**DESCRIPTION**  
 Insulation class  
 Series 2 =F Series 5=H  
 Voltage tolerance  
 AC +15% -10%  
 DC ± 10%  
 Protection class  
 IP65 with connector fitted  
 IP00 without connector  
 Continuous service ED100%

**OPTIONS**  
 Class H insulation (series 2)  
 Cable attached  
 Special coil voltage  
 Special coil powers  
 CE certified coils

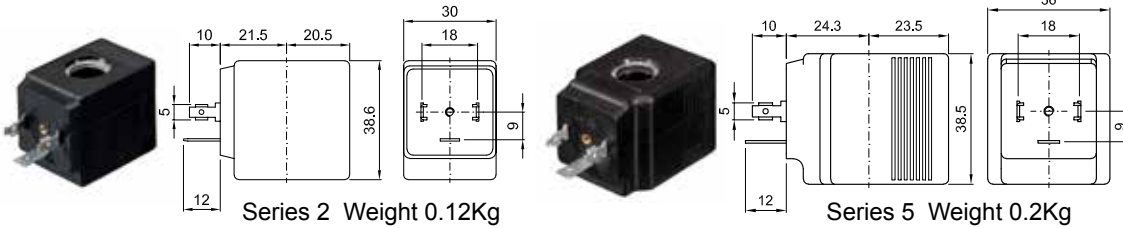

### SPARE PARTS LIST

1. Coil fixing nut
2. Coil
3. Seal assembly
4. Armature tube with core

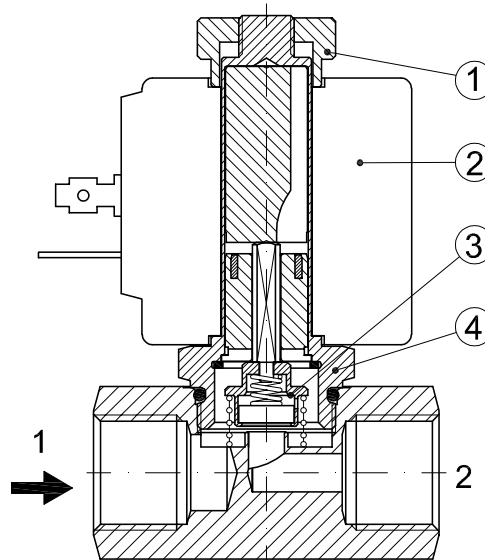

### OVERALL DIMENSION

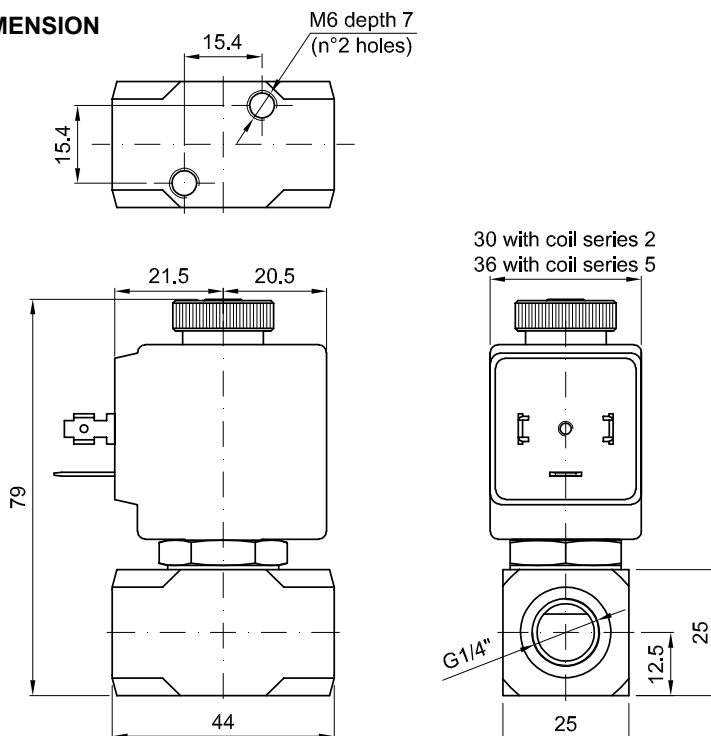

Weight with coil series 2=0.30Kg  
 Weight with coil series 5=0.38Kg

**DESCRIPTION**

Solenoid valve 2 way normally open  
direct acting poppet type

**CONSTRUCTION**

Body	Stainless steel
Armature tube	Stainless steel
Plunger and core	Stainless steel
Springs	Stainless steel
Seal material	NBR - FPM - EPDM

**FEATURES**

Maximum allowable pressure 50bar\*  
 Maximum fluid viscosity 25cSt (mm<sup>2</sup>/s)  
 Ambient temperature: with class F coil -10°C +55°C  
 with class H coil -10°C +80°C  
 Universal mounting position

**OPTIONS:** Silver shading ring  
 Version for use with industrial oxygen  
 c us certified coils



**2**

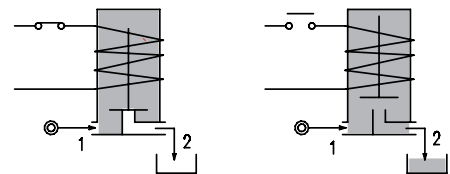
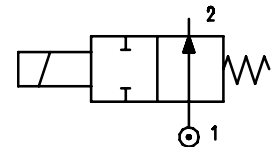

CODE ① ②	Connection G ISO 228	Orifice mm	Kv m <sup>3</sup> /h	Differential pressure bar			Nominal power			Coil		Seal ①	Temp. range °C			
				Min	Max		AC Inrush	VA Holding	DC Watt	Series	Width					
					AC	DC										
E210C...20///...	3/8"	2	0.1	0	16	-	20	15	-	2	30	NBR=B EPDM=E FPM=V	-10 +90			
E210C...35///...		3.5	0.32	0	7	-										
E210C...52///...		5.2	0.47	0	3	-										
E210D...20///...	1/2"	2	0.1	0	16	-	40	30	27	5	36			-10 +140		
E210D...35///...		3.5	0.32	0	7	-										
E210D...52///...		5.2	0.47	0	3	-										
E210C...20///...	3/8"	2	0.1	0	16	16	-	-	10	2	30				-10 +140	
E210C...35///...		3.5	0.32	0	7	7										
E210C...52///...		5.2	0.47	0	3	3										
E210C...64/...	1/2"	6.4	0.64	0	3.5	3.5	-	-	-	-	-					-10 +140
E210D...20///...		2	0.1	0	16	16										
E210D...35///...		3.5	0.32	0	7	7										
E210D...52///...	5.2	0.47	0	3	3	-	-	-	-	-	-10 +140					
E210D...64///...	6.4	0.64	0	3.5	3.5											
D210C...20///...	2	0.1	0	-	16											
D210C...35/3/...	3/8"	3.5	0.32	0	-	4	-	-	-	-		-	-10 +140			
D210C...52/3/...		5.2	0.47	0	-	2.2										
D210D...20///...		2	0.1	0	-	16										
D210D...35/3/...	1/2"	3.5	0.32	0	-	4	-	-	-	-		-		-10 +140		
D210D...52/3/...		5.2	0.47	0	-	2.2										

① Seal Example: E210DB///201 NBR seal  
 ② Coil Coil 24V DC

\* REMARK: The maximum allowable pressure PS for steam is 2,5bar (gauge pressure)

COILS	Alternating Current 50/60Hz Volt							Direct Current Volt			Electrical connection	Connectors
	12	24	48	110	220 230	240	380	12	24	48		
Series 2 Width 30 Code ②	20A	20B	20C	20D	20E	20F	20G	200	201	202	DIN 43650A	PG9 code 10349000
Series 5 Width 36 Code ②	52A	52B	52C	52D	52E	52F	52G	520	521	522	DIN 43650A	PG11 code 10349001

**DESCRIPTION**  
 Insulation class  
 Series 2 =F Series 5=H  
 Voltage tolerance  
 AC +15% -10%  
 DC ± 10%  
 Protection class  
 IP65 with connector fitted  
 IP00 without connector  
 Continuous service ED100%

**OPTIONS**  
 Class H insulation (series 2)  
 Cable attached  
 Special coil voltage  
 Special coil powers  
 CE certified coils

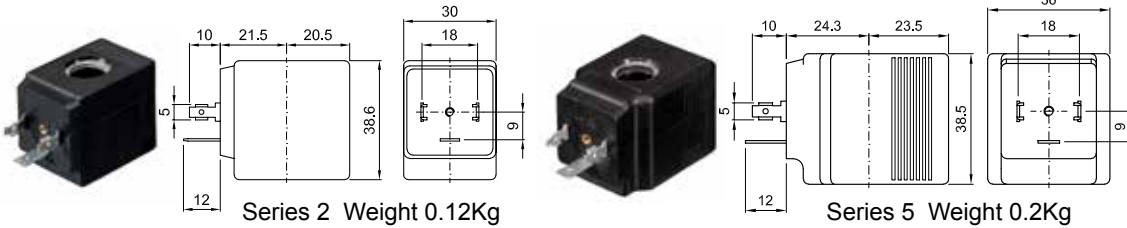

### SPARE PARTS LIST

1. Coil fixing nut
2. Coil
3. Seal assembly
4. Armature tube with core

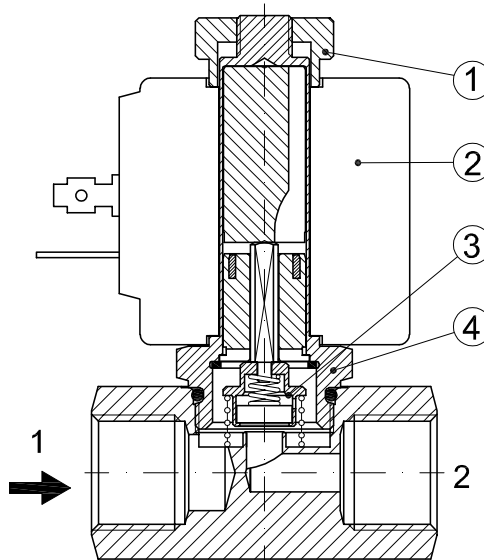

### OVERALL DIMENSION

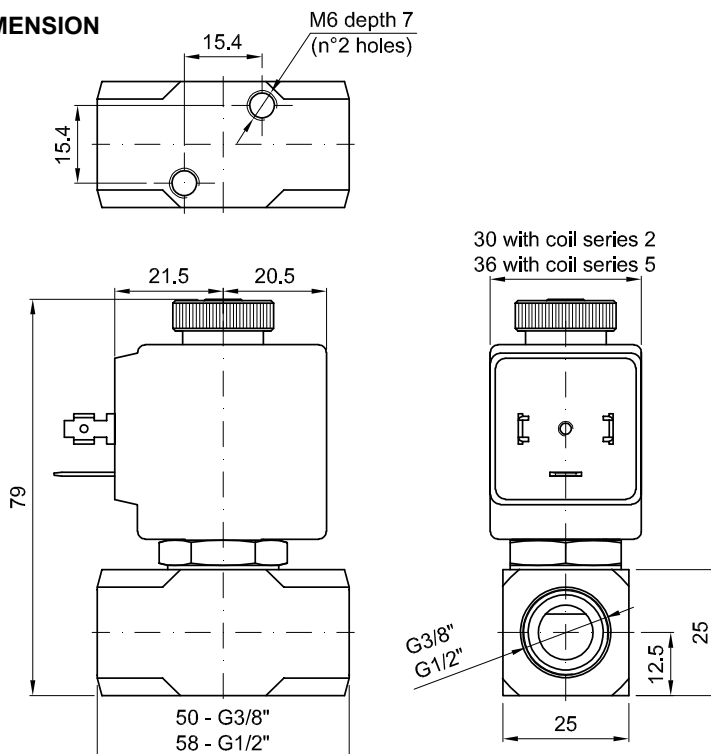

Weight with coil series 2=0.30Kg  
 Weight with coil series 5=0.38Kg

**DESCRIPTION**

Solenoid valve 2 way normally open  
direct acting poppet type

**CONSTRUCTION**

Body	Stainless steel
Armature tube	Stainless steel
Plunger and core	Stainless steel
Springs	Stainless steel
Seal material	NBR - FPM - EPDM



**2**

**FEATURES**

Maximum allowable pressure: 50 bar\*  
 Maximum fluid viscosity 25cSt (mm<sup>2</sup>/s)  
 Ambient temperature: with class F coil -10°C +55°C  
 with class H coil -10°C +80°C  
 Universal mounting position

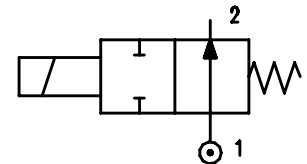

**OPTIONS:** Explosion proof coil according to ATEX - EExmII Series 7  
 Version for use with industrial oxygen  
 us certified coils

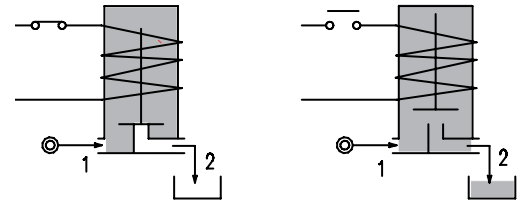

CODE ① ②	Connection G ISO 228	Orifice mm	Kv m <sup>3</sup> /h	Differential pressure bar			Nominal power			Coil		Temp. range °C	
				Min	Max		AC Inrush	VA Holding	DC Watt	Series	Width		Seal ①
E211A...12///...	1/8"	1.2	0.04	0	19	19	12	8	6.5	3	22	NBR=B	-10 +90
E211A...15///...		1.5	0.06	0	14	14						EPDM=E	<+140
E211A...20///...		2	0.09	0	8	8						FPM=V	-10 +140
E211A...25///...		2.5	0.14	0	4.5	4.5							
E211A...31///...		3.1	0.19	0	2.5	2.5							

① Seal Example: E211AB15///300 NBR seal  
 ② Coil Coil 12V DC

\* REMARK: The maximum allowable pressure PS for steam is 2,5bar (gauge pressure)

COILS	Alternating Current 50/60Hz Volt							Direct Current Volt			Electrical connection	Connectors
	12	24	48	110	220 230	240	380	12	24	48		
Series 3 Width 22 Code ②	30A	30B	30C	30D	30E	30F	30G	300	301	302	DIN 46244	PG9 code 10348000

**DESCRIPTION**  
 Class F insulation  
 Voltage tolerance  
 AC +15% -10%  
 DC ± 10%  
 Protection class  
 IP65 with connector fitted  
 IP00 without connector  
 Continuous service ED100%

**OPTIONS**  
 Class H insulation  
 Cable attached  
 Special coil voltage  
 Special coil powers  
 cULus certified coils

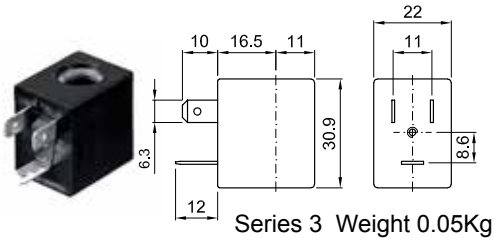

### SPARE PARTS LIST

1. Coil fixing nut
2. Coil
3. Seal assembly
4. Armature tube with core

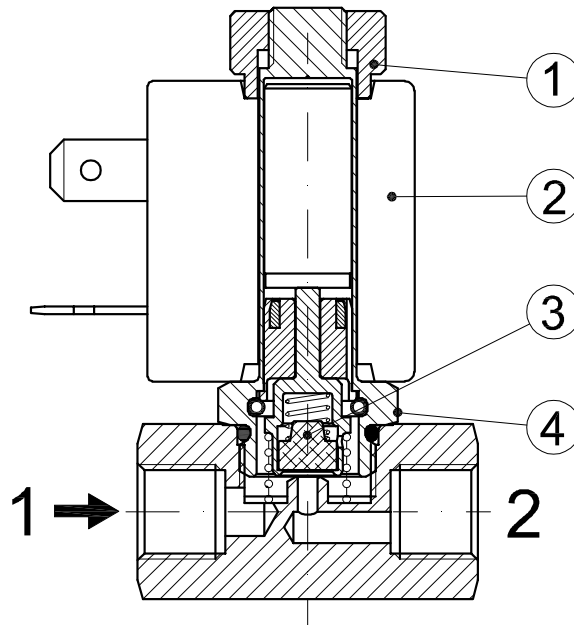

### OVERALL DIMENSION

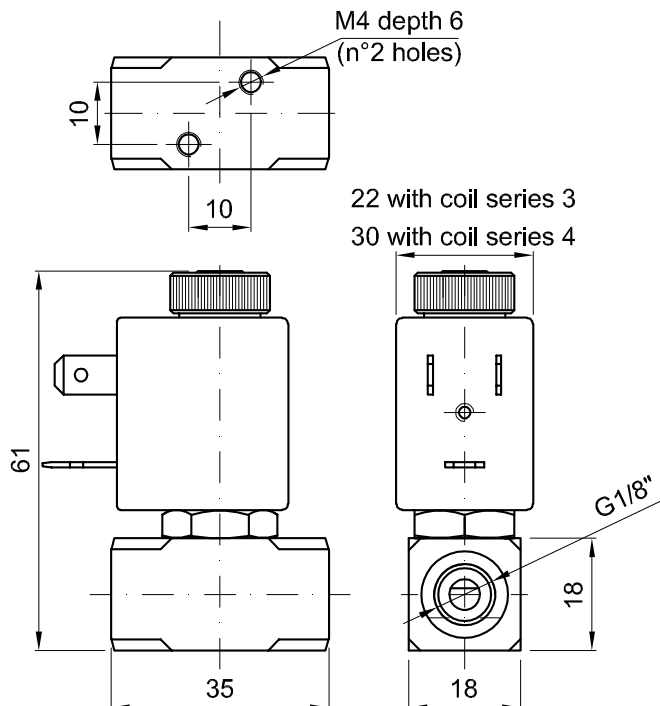

Weight = 0.15Kg



**DESCRIPTION**

Solenoid valve 2 way normally open  
direct acting poppet type

**CONSTRUCTION**

Body	Brass
Armature tube	Brass
Plunger and core	Stainless steel
Springs	Stainless steel
Seal material	NBR - FPM - EPDM



**2**

**FEATURES**

Maximum allowable pressure: 50 bar\*  
 Maximum fluid viscosity 25cSt (mm<sup>2</sup>/s)  
 Ambient temperature: with class F coil -10°C +55°C  
 with class H coil -10°C +80°C  
 Universal mounting position

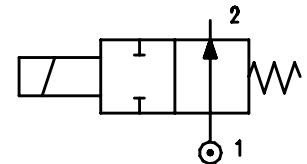

**OPTIONS:** Stainless steel armature tube  
 Electroless nickel plating  
 Explosion proof coil according to ATEX - EExmII Series 7  
 c us certified coils

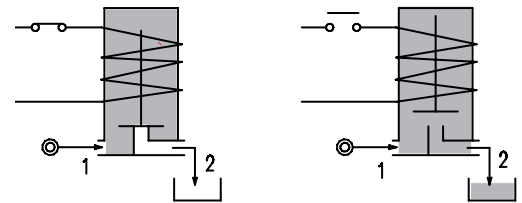

CODE ① ②	Flange □ 25	Orifice mm	Kv m <sup>3</sup> /h	Differential pressure bar		Nominal power			Coil		Temp. range °C	
				Min	Max	AC Inrush	VA Holding	DC Watt	Series	Width		Seal ①
E212X...12///...	□ 25	1.2	0.04	0	19	12	8	6.5	3	22	NBR=B EPDM=E FPM=V	-10 +90 <+140 -10 +140
E212X...15///...		1.5	0.06	0	14							
E212X...20///...		2	0.09	0	8							
E212X...25///...		2.5	0.14	0	4.5							

① Seal Example: E212AB15///300 NBR seal  
 ② Coil Coil 12V DC

\* REMARK: The maximum allowable pressure PS for steam is 2,5bar (gauge pressure)

COILS	Alternating Current 50/60Hz Volt							Direct Current Volt			Electrical connection	Connectors
	12	24	48	110	220 230	240	380	12	24	48		
Series 3 Width 22 Code ②	30A	30B	30C	30D	30E	30F	30G	300	301	302	DIN 46244	PG9 code 10348000

**DESCRIPTION**  
 Class F insulation  
 Voltage tolerance  
 AC +15% -10%  
 DC ± 10%  
 Protection class  
 IP65 with connector fitted  
 IP00 without connector  
 Continuous service ED100%

**OPTIONS**  
 Class H insulation  
 Cable attached  
 Special coil voltage  
 Special coil powers  
 cULus certified coils

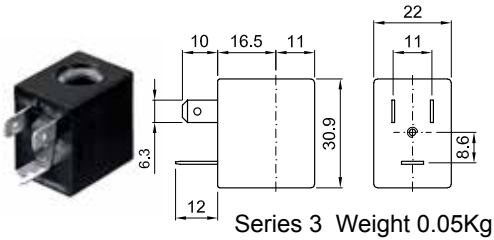

Series 3 Weight 0.05Kg

### SPARE PARTS LIST

1. Coil fixing nut
2. Coil
3. Seal assembly
4. Armature tube with core

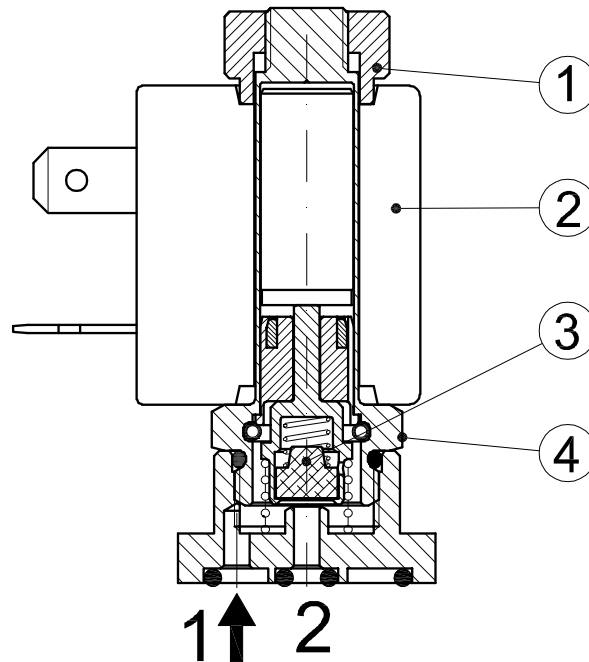

### OVERALL DIMENSION

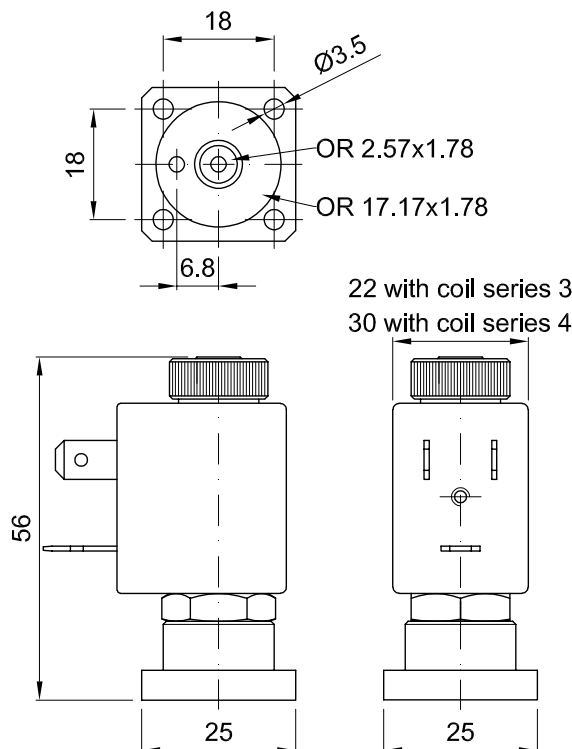

Weight = 0.15Kg

**DESCRIPTION**

Solenoid valve 2 way normally open  
direct acting poppet type

**CONSTRUCTION**

Body	Brass
Armature tube	Brass
Plunger and core	Stainless steel
Springs	Stainless steel
Seal material	NBR - FPM - EPDM



**2**

**FEATURES**

Maximum allowable pressure 50bar\*  
 Maximum fluid viscosity 25cSt (mm<sup>2</sup>/s)  
 Ambient temperature: with class F coil -10°C +55°C  
 with class H coil -10°C +80°C  
 Universal mounting position

**OPTIONS:** Stainless steel armature tube  
 Electroless nickel plating  
 cULus certified coils

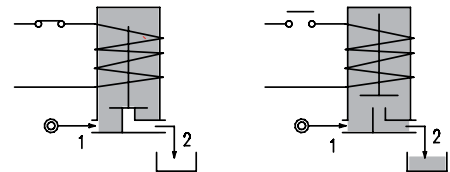
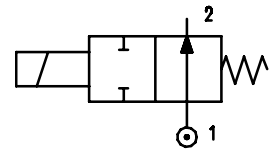

CODE ① ②	Flange □ 32	Orifice mm	Kv m <sup>3</sup> /h	Differential pressure bar			Nominal power			Coil		Seal ①	Temp. range °C
				Min	Max		AC Inrush	VA Holding	DC Watt	Series	Width		
					AC	DC							
E214X...15///...	□ 32	1.5	0.07	0	23	-	20	15	-	2	30	NBR=B	-10 +90
E214X...20///...		2	0.1	0	17	-							
E214X...25///...		2.5	0.15	0	12	-							
E214X...35///...		3.5	0.32	0	7	-							
E214X...45///...		4.5	0.41	0	4.5	-							
E214X...15///...	□ 32	1.5	0.07	0	23	23	40	30	27	5	36	EPDM=E	-10 +140
E214X...20///...		2	0.1	0	17	17							
E214X...25///...		2.5	0.15	0	12	12							
E214X...35///...		3.5	0.32	0	7	7							
E214X...45///...		4.5	0.41	0	4.5	4.5							
D214X...15/3/...	□ 32	1.5	0.07	0	-	18	-	-	10	2	30	FPM=V	-10 +140
D214X...20/3/...		2	0.1	0	-	11							
D214X...25/3/...		2.5	0.15	0	-	7							
D214X...35/3/...		3.5	0.32	0	-	4							
D214X...45/5/...		4.5	0.41	0	-	3							

① Seal Example: E214XB20///20E NBR seal  
 ② Coil Coil 230V 50/60Hz

\* REMARK: The maximum allowable pressure PS for steam is 2,5bar (gauge pressure)

COILS	Alternating Current 50/60Hz Volt							Direct Current Volt			Electrical connection	Connectors
	12	24	48	110	220 230	240	380	12	24	48		
Series 2 Width 30 Code ②	20A	20B	20C	20D	20E	20F	20G	200	201	202	DIN 43650A	PG9 code 10349000
Series 5 Width 36 Code ②	52A	52B	52C	52D	52E	52F	52G	520	521	522	DIN 43650A	PG11 code 10349001

**DESCRIPTION**  
 Insulation class  
 Series 2 =F Series 5=H  
 Voltage tolerance  
 AC +15% -10%  
 DC ± 10%  
 Protection class  
 IP65 with connector fitted  
 IP00 without connector  
 Continuous service ED100%

**OPTIONS**  
 Class H insulation (series 2)  
 Cable attached  
 Special coil voltage  
 Special coil powers  
 us certified coils

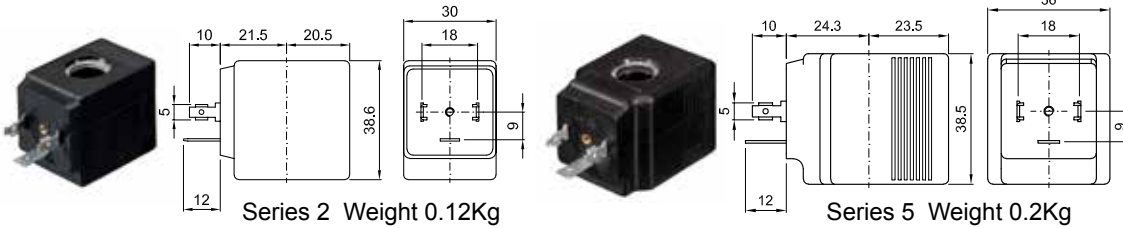

### SPARE PARTS LIST

1. Coil fixing nut
2. Coil
3. Seal assembly
4. Armature tube with core

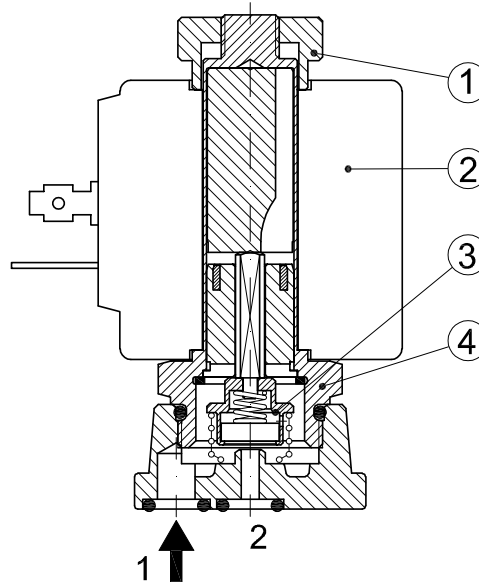

### OVERALL DIMENSION

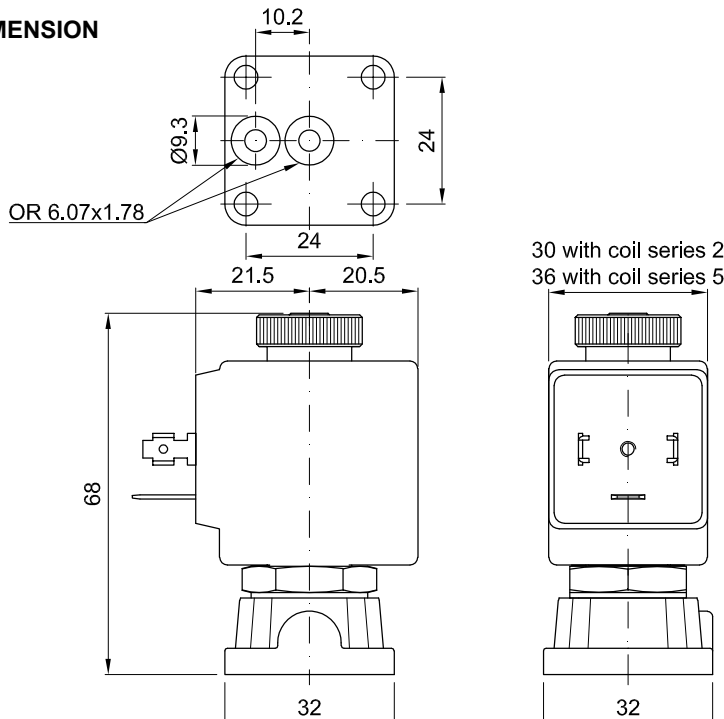

Weight with coil series 2=0.25Kg  
 Weight with coil series 5=0.33Kg

**DESCRIPTION**

Solenoid valve 2 way normally open direct acting poppet type, suitable for food applications and all compatible fluids.

**CONSTRUCTION**

Body	Thermoplastic polymer NSF, WRC, KTW, FDA certified
Armature tube	Brass chemically nickel plated
Plunger and core	Stainless steel
Springs	Stainless steel
Seal material	NBR - FPM - EPDM (food contact certified)



**2**

**FEATURES**

- Maximum allowable pressure 20bar\*
- Maximum fluid viscosity 25cSt (mm<sup>2</sup>/s)
- Ambient temperature: with class F coil -10°C +55°C  
with class H coil -10°C +80°C
- Universal mounting position

**OPTIONS:** Stainless steel armature tube  
Type N connection without nut  
UL certified coils

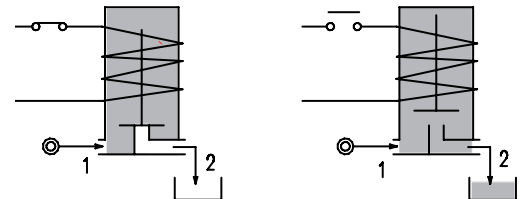
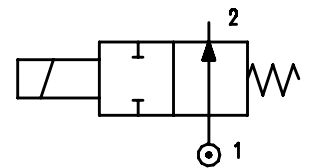

CONNECTION					
K	N	P	W	Y	Z
<b>SPIGGOT</b>	<b>G1/8" male thread with NUT for flexible pipes</b>	<b>HOSETAIL for flexible pipes</b>	<b>COMPRESSION for flexible and semiflexible pipes</b>	<b>PUSH IN for semiflexible pipes Øext 6</b>	<b>PUSH IN for semiflexible pipes Øext 4</b>

CODE ① ②	Connection *	Orifice mm	Kv m <sup>3</sup> /h	Differential pressure bar			Nominal power			Coil		Seal ①	Temp. range ** °C
				Min	Max		AC Inrush	VA Holding	DC Watt	Series	Width		
					AC	DC							
E235*...15///...	K-N-P-W-Y-Z	1.5	0.06	0	14	14	12	8	6.5	3	22	NBR=A	-10 +90
E235*...20///...	K-N-P-W-Y-Z	2	0.09	0	8	8						EPDM=E	-10 +140
E235*...25///...	K-N-P-W-Y-Z	2.5	0.14	0	4.5	4.5						FPM=V	-10 +140

- ① Seal Example: E235KA20///30B NBR seal SPIGGOT connection
- ② Coil Coil 24V 50/60Hz
- ③ Only for connection "W" E235W.../1/...

\* REMARK: The maximum allowable pressure PS for steam is 2,5bar

\*\* The temperature range is related to the material of the seals (NBR, EPDM, FPM), and the valves' body. Please contact us concerning the temperature range referred to the different types of connection.

COILS	Alternating Current 50/60Hz Volt							Direct Current Volt			Electrical connection	Connectors
	12	24	48	110	220 230	240	380	12	24	48		
Series 3 Width 22 Code ②	30A	30B	30C	30D	30E	30F	30G	300	301	302	DIN 46244	PG9 code 10348000

**DESCRIPTION**  
 Class F insulation  
 Voltage tolerance  
 AC +15% -10%  
 DC ± 10%  
 Protection class  
 IP65 with connector fitted  
 IP00 without connector  
 Continuous service ED100%

**OPTIONS**  
 Class H insulation  
 Cable attached  
 Special coil voltage  
 Special coil powers  
 CE certified coils

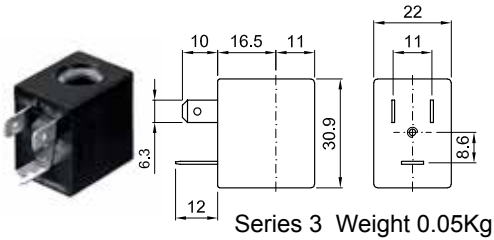

Series 3 Weight 0.05Kg

### SPARE PARTS LIST

1. Coil fixing nut
2. Coil
3. Seal assembly
4. Armature tube with core

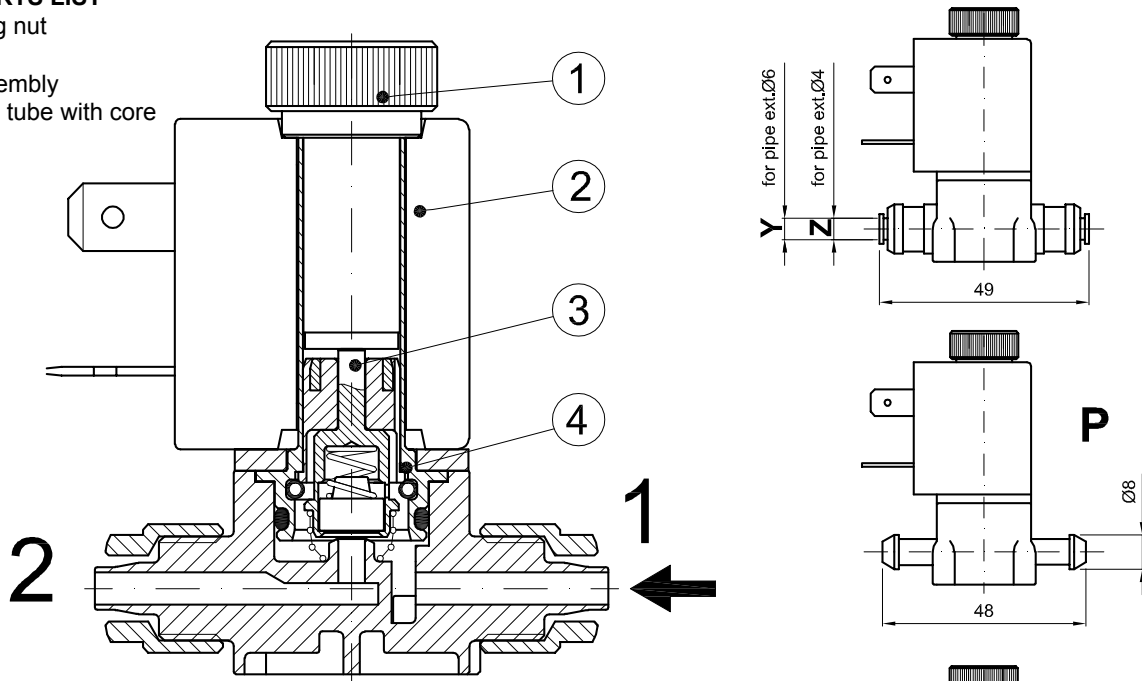

Weight=0.10Kg

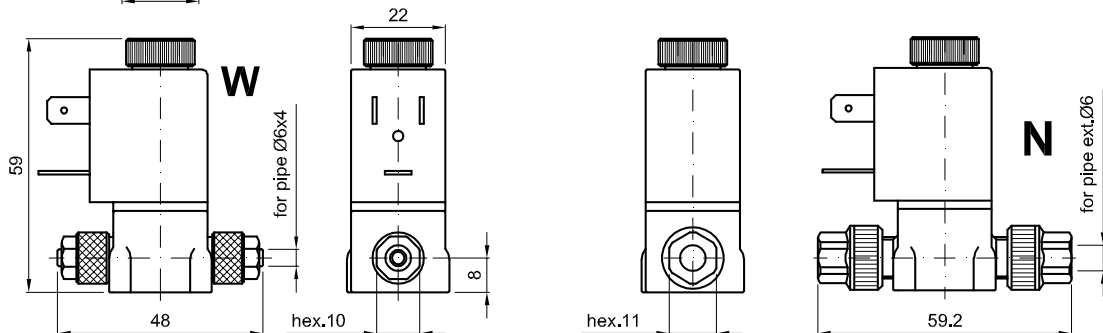
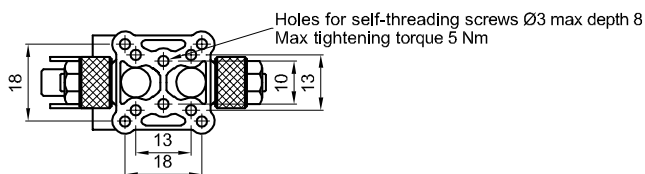

Nut max torque 2Nm

Screw the nut with wrench 11 up to the sliding on the hexagon (torque limiting device)

**DESCRIPTION**

Solenoid valve 3 way  
direct acting poppet type

**CONSTRUCTION**

Body	Brass
Armature tube	Brass
Plunger and core	Stainless steel
Springs	Stainless steel
Seal material	NBR - FPM - EPDM



**FEATURES**

Maximum allowable pressure : maximum differential pressure +10%

Maximum fluid viscosity 25cSt (mm<sup>2</sup>/s)

Ambient temperature: with class F coil -10°C +55°C  
with class H coil -10°C +80°C

Universal mounting position

- OPTIONS:** Stainless steel armature tube  
Electroless nickel plating  
Series 7 explosion proof coil according to ATEX - EExmII  
Exhaust port with hosetail connection  
c US certified coils

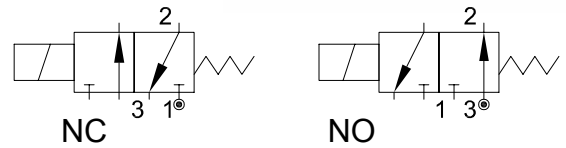

**3**

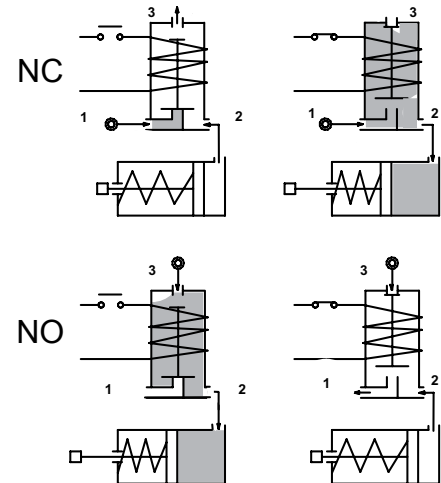

CODE ① ②	Connection G ISO 228	Orifice mm		Kv m <sup>3</sup> /h	Differential pressure bar			Nominal power			Coil		Seal ①	Temp. range °C
		Inlet	Exh.		Min	Max AC DC		AC Inrush	VA Holding	DC Watt	Series	Width		
<b>NC Normally closed</b>													NBR=B	-10 +90
E304A...15///...		1.5	1.5	0.06	0	10	10	12	8	6.5	3	22		
<b>NO Normally open</b>													EPDM=E	-10 +140
E304A...15/S/...		1.5	1.5	0.06	0	10	10	12	8	6.5	3	22		

- ① Seal  
② Coil

Example: E304AB15///30B NBR seal  
Coil 24V 50/60Hz

COILS	Alternating Current 50/60Hz Volt							Direct Current Volt			Electrical connection	Connectors
	12	24	48	110	220 230	240	380	12	24	48		
Series 3 Width 22 Code ②	30A	30B	30C	30D	30E	30F	30G	300	301	302	DIN 46244	PG9 code 10348000

**DESCRIPTION**  
 Class F insulation  
 Voltage tolerance  
 AC +15% -10%  
 DC ± 10%  
 Protection class  
 IP65 with connector fitted  
 IP00 without connector  
 Continuous service ED100%

**OPTIONS**  
 Class H insulation  
 Cable attached  
 Special coil voltage  
 Special coil powers  
 cULus certified coils

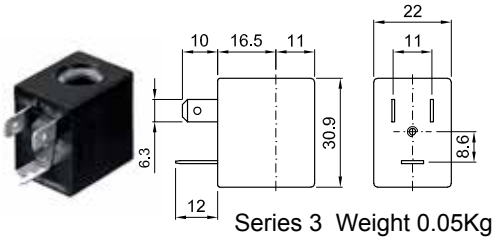

### SPARE PARTS LIST

1. Coil fixing nut
2. Coil
3. Plunger
4. Armature tube with core

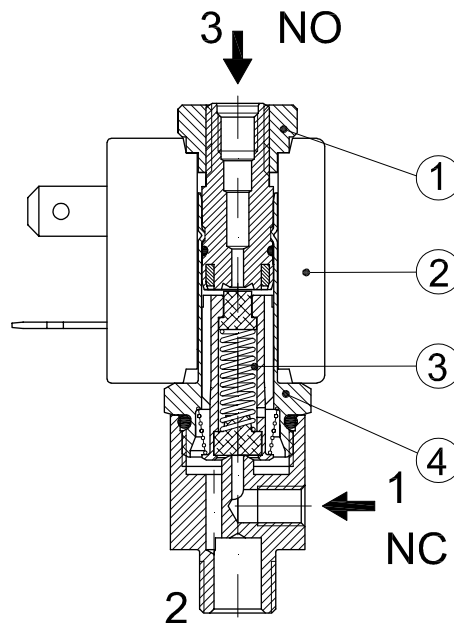

### OVERALL DIMENSION

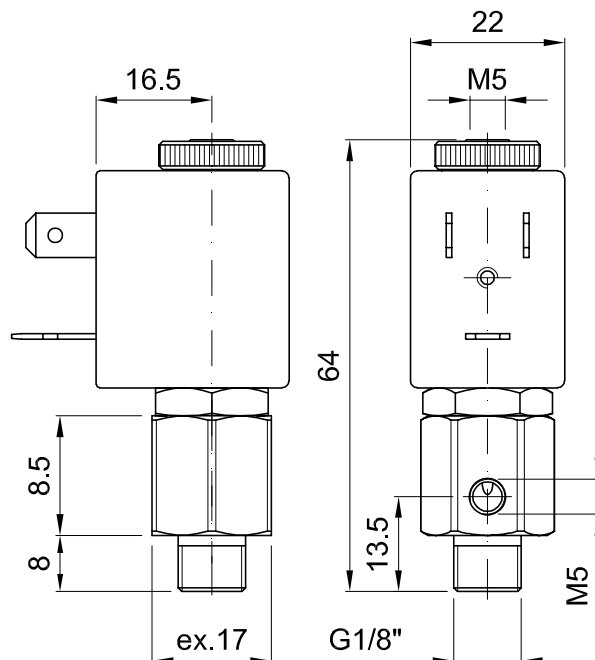

Weight=0.11Kg



**DESCRIPTION**

Solenoid valve 3 way  
direct acting poppet type

**CONSTRUCTION**

Body	Brass
Armature tube	Brass
Plunger and core	Stainless steel
Springs	Stainless steel
Seal material	NBR - FPM - EPDM



**3**

**FEATURES**

Maximum allowable pressure : maximum differential pressure +10%  
 Maximum fluid viscosity 25cSt (mm<sup>2</sup>/s)  
 Ambient temperature: with class F coil -10°C +55°C  
 with class H coil -10°C +80°C  
 Universal mounting position

**OPTIONS:** Manual override  
 Stainless steel armature tube  
 Electroless nickel plating  
 Series 7 explosion proof coil according to ATEX - EExmII  
 Exhaust port with hosedetail connection  
 cULus certified coils

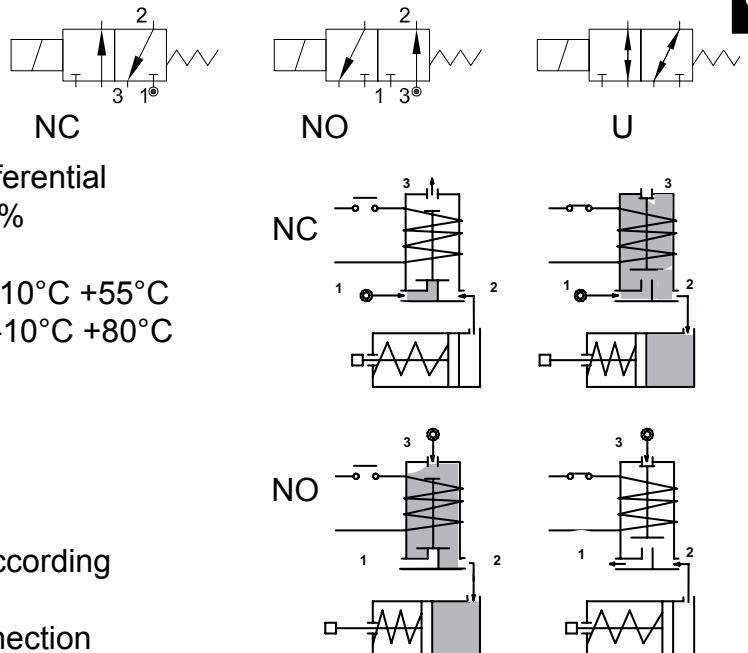

CODE ① ②	Connection G ISO 228	Orifice mm		Kv m <sup>3</sup> /h	Differential pressure bar			Nominal power			Coil		Seal ①	Temp. range °C		
		Inlet	Exh.		Min	Max		AC	VA	DC	Series	Width				
<b>NC Normally closed</b>																
E305A...12///...	1/8"	1.2	1.5	0.04	0	15	15	12	8	6.5	3	22	NBR=B EPDM=E FPM=V	-10 +90 -10 +140 -10 +140		
E305A...15///...		1.5	1.5	0.06	0	10	10									
E305A...20///...		2	1.7	0.09	0	6	6									
<b>NO Normally open</b>																
E305A...15/S/...	1/8"	1.5	1.5	0.06	0	10	10	12	8	6.5	3	22			NBR=B EPDM=E FPM=V	-10 +90 -10 +140 -10 +140
E305A...17/S/...		1.7	2	0.07	0	6	6									
<b>U Universal</b>																
E305A...15/G/...	1/8"	1.5	1.5	0.06	0	6	6	12	8	6.5	3	22	NBR=B EPDM=E FPM=V	-10 +90 -10 +140 -10 +140		

① Seal  
 ② Coil  
 Example: E305AV15///30B FPM seal Coil 24V 50/60Hz NC  
 E305AB15/S/301 NBR seal Coil 24V DC NO

COILS	Alternating Current 50/60Hz Volt							Direct Current Volt			Electrical connection	Connectors
	12	24	48	110	220 230	240	380	12	24	48		
Series 3 Width 22 Code ②	30A	30B	30C	30D	30E	30F	30G	300	301	302	DIN 46244	PG9 code 10348000

**DESCRIPTION**  
 Class F insulation  
 Voltage tolerance  
 AC +15% -10%  
 DC ± 10%  
 Protection class  
 IP65 with connector fitted  
 IP00 without connector  
 Continuous service ED100%

**OPTIONS**  
 Class H insulation  
 Cable attached  
 Special coil voltage  
 Special coil powers  
 CE us certified coils

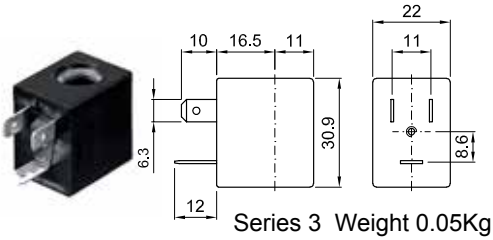

Series 3 Weight 0.05Kg

### SPARE PARTS LIST

1. Coil fixing nut
2. Coil
3. Plunger
4. Armature tube with core

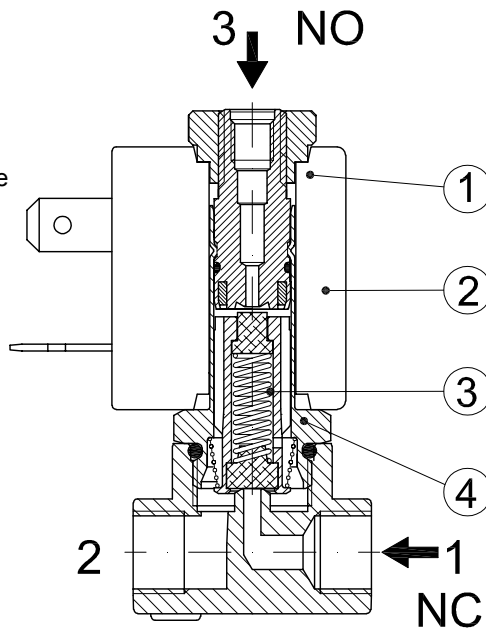

### MANUAL OVERRIDE

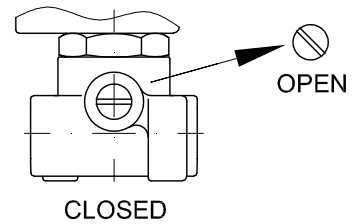

### OVERALL DIMENSION

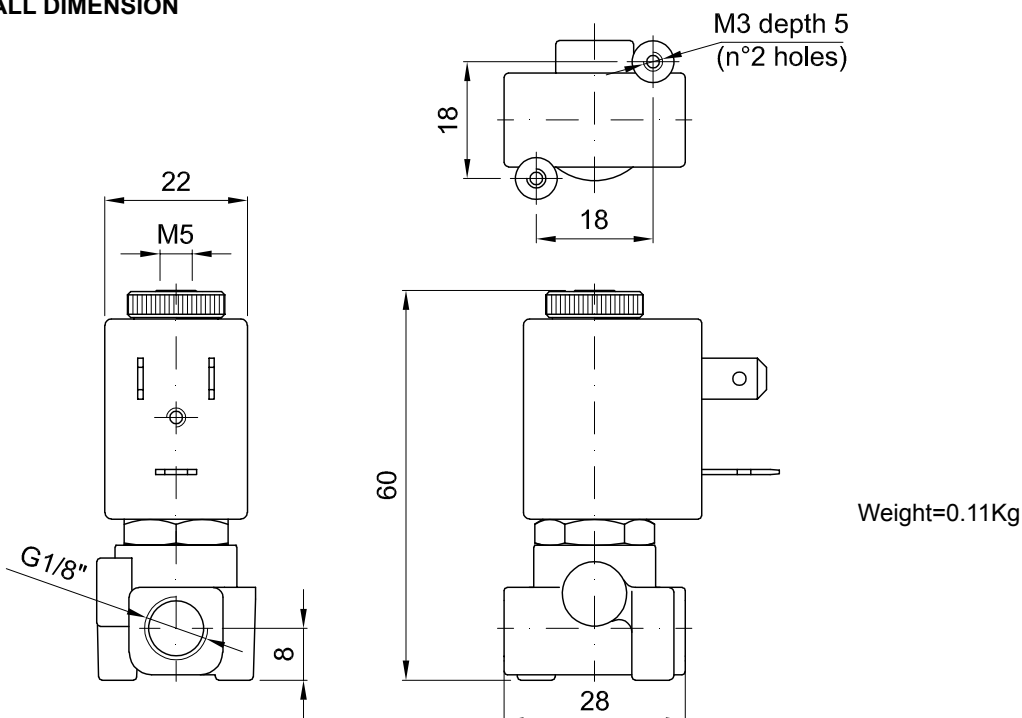

**DESCRIPTION**

 Solenoid valve 3 way  
 direct acting poppet type

**CONSTRUCTION**

Body	Brass
Armature tube	Stainless steel
Plunger and core	Stainless steel
Springs	Stainless steel
Seal material	NBR - FPM - EPDM



3

**FEATURES**

Maximum allowable pressure : maximum differential pressure +10%

Maximum fluid viscosity 25cSt (mm<sup>2</sup>/s)

Ambient temperature: with class F coil -10°C +55°C  
 with class H coil -10°C +80°C

Universal mounting position

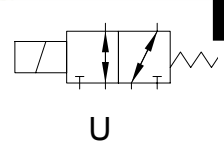
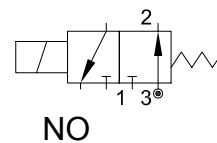
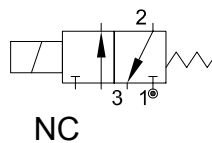

**OPTIONS:** Manual override  
 Electroless nickel plating  
 Stainless steel seat  
 c us certified coils

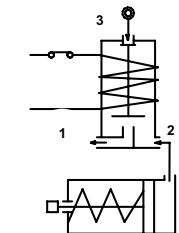
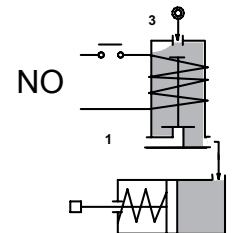
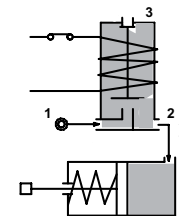
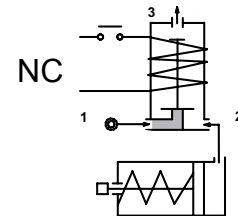

CODE	Connection G	Orifice mm		Kv m <sup>3</sup> /h	Differential pressure bar			Nominal power			Coil		Seal	Temp. range °C
		① Inlet	② Exh.		Min	Max		AC	VA	DC	Series	Width		
	ISO 228						AC	DC	Inrush	Holding	Watt			
<b>NC Normally closed</b>														
E306A...15//...	1/8"	1.5	2.4	0.07	0	20	20	20	15	10	2	30	NBR=B  EPDM=E  FPM=V	-10 +90  -10 +140  -10 +140
E306A...20//...		2	2.4	0.11	0	13	13							
E306A...25//...		2.5	2.4	0.16	0	10	10							
E306B...15//...	1/4"	1.5	2.4	0.07	0	20	20	20	15	10	2	30		
E306B...20//...		2	2.4	0.11	0	13	13							
E306B...25//...		2.5	2.4	0.16	0	10	10							
<b>NO Normally open</b>														
E306B...25/S/...	1/4"	2.4	2.5	0.16	0	9	9	20	15	10	2	30	FPM=V	-10 +140
E306B...29/S/...		2.9	3	0.20	0	6.5	6.5							
<b>U Universal</b>														
E306B...25/G/...	1/4"	2.5	2.4	0.16	0	5	4	20	15	10	2	30		

① Seal  
 ② Coil

Example: E306BV15//20B FPM seal      Coil 24V 50/60Hz NC  
 E306BB24/S/201 NBR seal      Coil 24V DC NO

COILS	Alternating Current 50/60Hz Volt							Direct Current Volt			Electrical connection	Connectors
	12	24	48	110	220 230	240	380	12	24	48		
Series 2 Width 30 Code ②	20A	20B	20C	20D	20E	20F	20G	200	201	202	DIN 43650A	PG9 code 10349000

**DESCRIPTION**  
 Insulation class  
 Series 2 =F Series 5=H  
 Voltage tolerance  
 AC +15% -10%  
 DC ± 10%  
 Protection class  
 IP65 with connector fitted  
 IP00 without connector  
 Continuous service ED100%

**OPTIONS**  
 Class H insulation (series 2)  
 Cable attached  
 Special coil voltage  
 Special coil powers  
 cULus certified coils

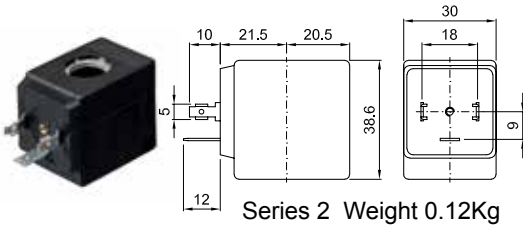

Series 2 Weight 0.12Kg

### SPARE PARTS LIST

1. Coil fixing nut
2. Coil
3. Plunger
4. Armature tube with core

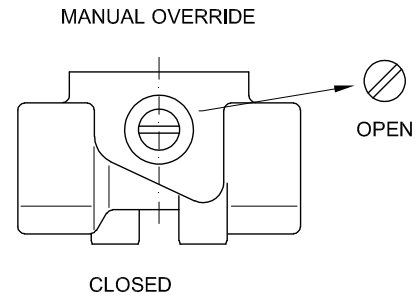
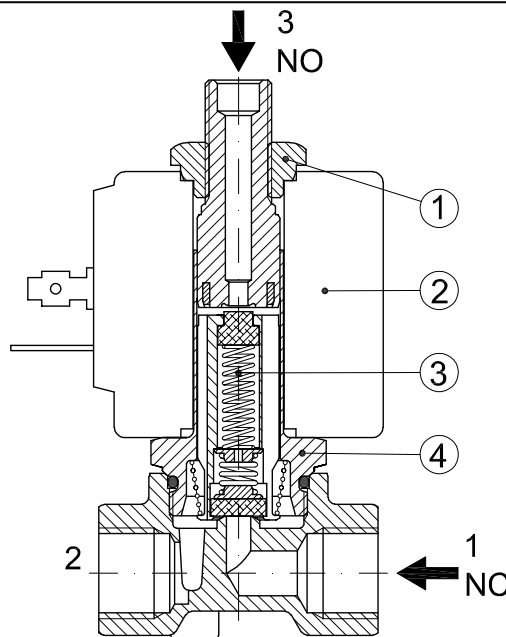

### OVERALL DIMENSION

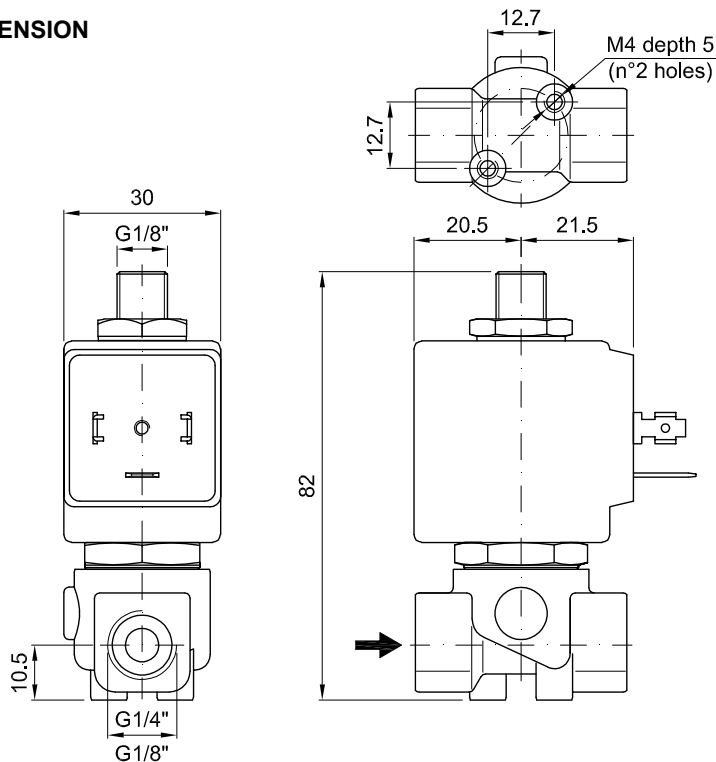

Weight=0.32Kg

**DESCRIPTION**

Solenoid valve 3 way normally open  
direct acting poppet type

**CONSTRUCTION**

Body	Brass
Armature tube	Brass
Plunger and core	Stainless steel
Springs	Stainless steel
Seal material	NBR - FPM - EPDM



**3**

**FEATURES**

Maximum allowable pressure : maximum differential pressure +10%

Maximum fluid viscosity 25cSt (mm<sup>2</sup>/s)

Ambient temperature: with class F coil -10°C +55°C  
with class H coil -10°C +80°C

Universal mounting position

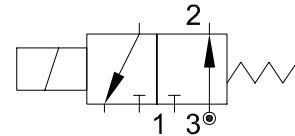

- OPTIONS:** Stainless steel armature tube  
Electroless nickel plating  
Series 7 explosion proof coil according to ATEX - EExmII  
Exhaust port with hosedtail connection  
c us certified coils

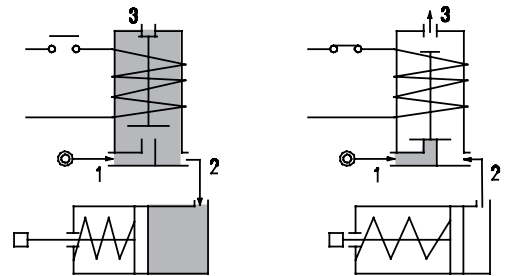

CODE ① ②	Connection G ISO 228	Orifice mm		Kv m <sup>3</sup> /h	Differential pressure bar			Nominal power			Coil		Seal ①	Temp. range °C
		Inlet	Exh.		Min	Max AC DC		AC Inrush	VA Holding	DC Watt	Series	Width		
E307A...12///...	1/8"	1.2	1.2	0.04	0	12	8	12	8	6.5	3	22	NBR=B EPDM=E FPM=V	-10 +90 -10 +140 -10 +140
E307A...15///...		1.5	1.2	0.06	0	9	6							

① Seal Example: E307AV15///301 FPM seal  
② Coil Coil 24V DC

COILS	Alternating Current 50/60Hz Volt							Direct Current Volt			Electrical connection	Connectors
	12	24	48	110	220 230	240	380	12	24	48		
Series 3 Width 22 Code ②	30A	30B	30C	30D	30E	30F	30G	300	301	302	DIN 46244	PG9 code 10348000

**DESCRIPTION**  
 Class F insulation  
 Voltage tolerance  
 AC +15% -10%  
 DC ± 10%  
 Protection class  
 IP65 with connector fitted  
 IP00 without connector  
 Continuous service ED100%

**OPTIONS**  
 Class H insulation  
 Cable attached  
 Special coil voltage  
 Special coil powers  
 cULus certified coils

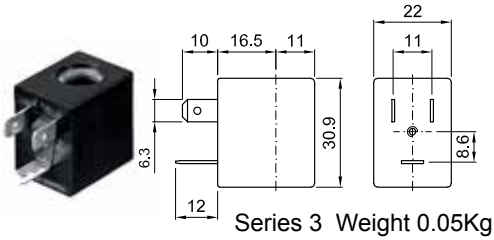

Series 3 Weight 0.05Kg

### SPARE PARTS LIST

1. Coil fixing nut
2. Coil
3. Seal assembly
4. Armature tube with core

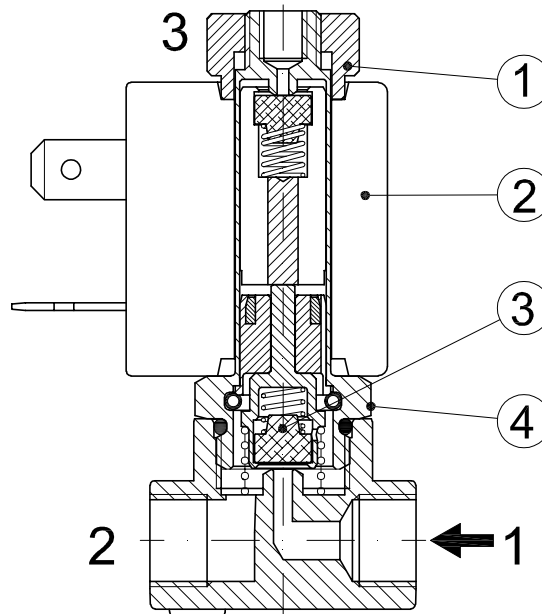

### OVERALL DIMENSION

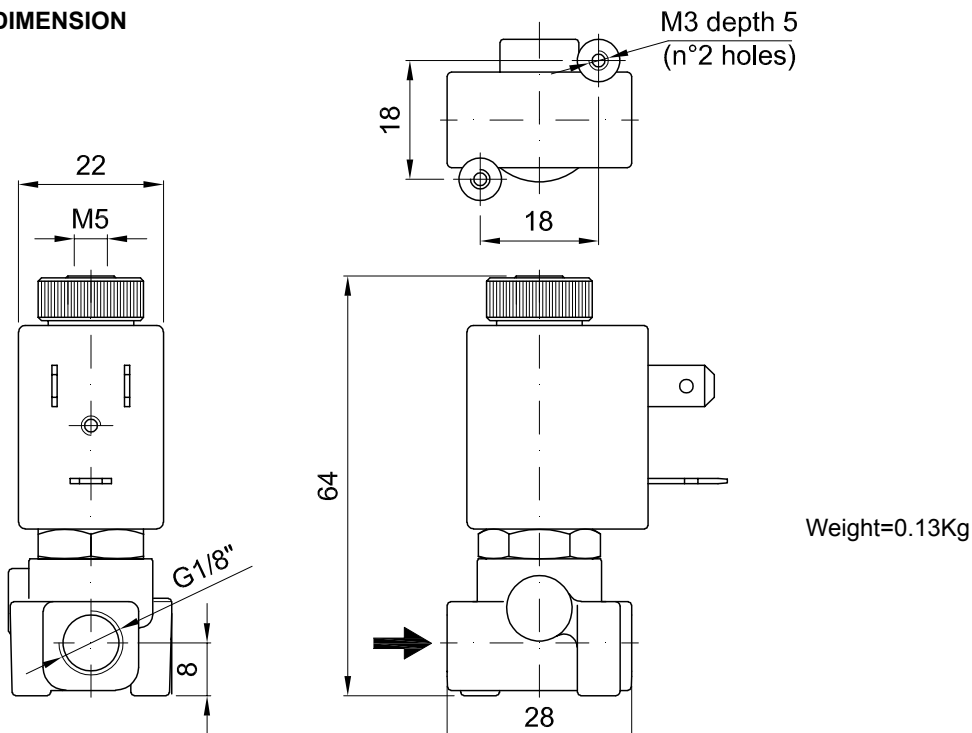

**DESCRIPTION**

Solenoid valve 3 way  
direct acting poppet type

**CONSTRUCTION**

Body	Stainless steel
Armature tube	Stainless steel
Plunger and core	Stainless steel
Springs	Stainless steel
Seal material	NBR - FPM - EPDM



**3**

**FEATURES**

Maximum allowable pressure : maximum differential pressure +10%  
 Maximum fluid viscosity 25cSt (mm<sup>2</sup>/s)  
 Ambient temperature: with class F coil -10°C +55°C  
 with class H coil -10°C +80°C  
 Universal mounting position

**OPTIONS:** Silver shading ring  
 cULus certified coils

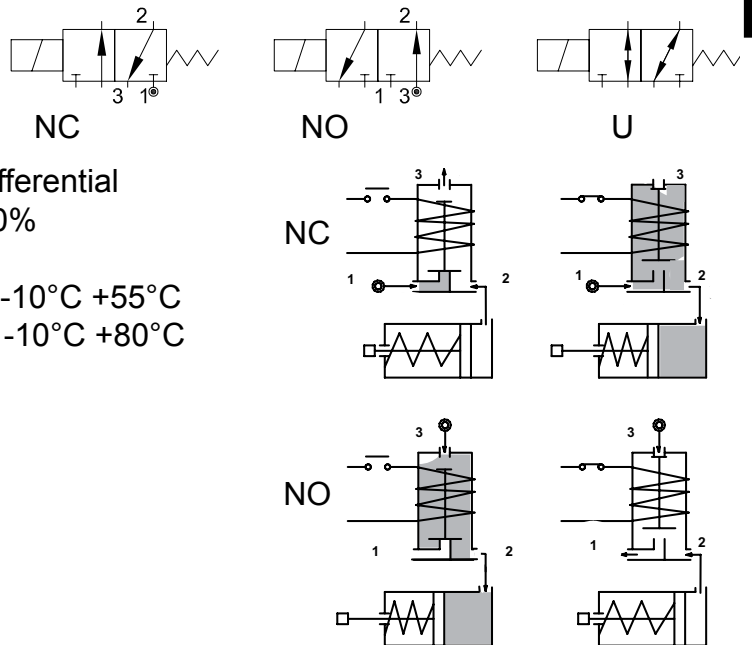

CODE ① ②	Connection G ISO 228	Orifice mm		Kv m <sup>3</sup> /h	Differential pressure bar			Nominal power			Coil		Seal ①	Temp. range °C		
		Inlet	Exh.		Min	Max AC DC		AC Inrush	VA Holding	DC Watt	Series	Width				
<b>NC Normally closed</b>																
E310B...20///...	1/4"	2	2.4	0.11	0	13	13	20	15	10	2	30	NBR=B EPDM=E FPM=V	-10 +90		
E310B...25///...		2.5	2.4	0.16	0	10	10									
<b>NO Normally open</b>																
E310B...25/S/...	1/4"	2.4	2.5	0.16	0	9	9	20	15	10	2	30			NBR=B EPDM=E FPM=V	-10 +140
E310B...29/S/...		2.9	3	0.20	0	6.5	6.5									
<b>U Universal</b>																
E310B...25/G/...	1/4"	2.5	2.4	0.16	0	5	4	20	15	10	2	30	NBR=B EPDM=E FPM=V	-10 +140		

① Seal  
 ② Coil

Example: E310BV15///20B FPM seal  
 E310BB24/S/201 NBR seal

Coil 24V 50/60Hz NC  
 Coil 24V DC NO

COILS	Alternating Current 50/60Hz Volt							Direct Current Volt			Electrical connection	Connectors
	12	24	48	110	220 230	240	380	12	24	48		
Series 2 Width 30 Code ②	20A	20B	20C	20D	20E	20F	20G	200	201	202	DIN 43650A	PG9 code 10349000

**DESCRIPTION**  
 Insulation class  
 Series 2 =F Series 5=H  
 Voltage tolerance  
 AC +15% -10%  
 DC ± 10%  
 Protection class  
 IP65 with connector fitted  
 IP00 without connector  
 Continuous service ED100%

**OPTIONS**  
 Class H insulation (series 2)  
 Cable attached  
 Special coil voltage  
 Special coil powers  
 US certified coils

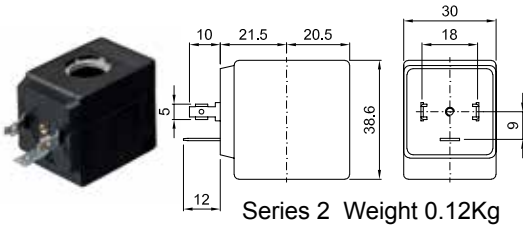

Series 2 Weight 0.12Kg

### SPARE PARTS LIST

1. Coil fixing nut
2. Coil
3. Plunger
4. Armature tube with core

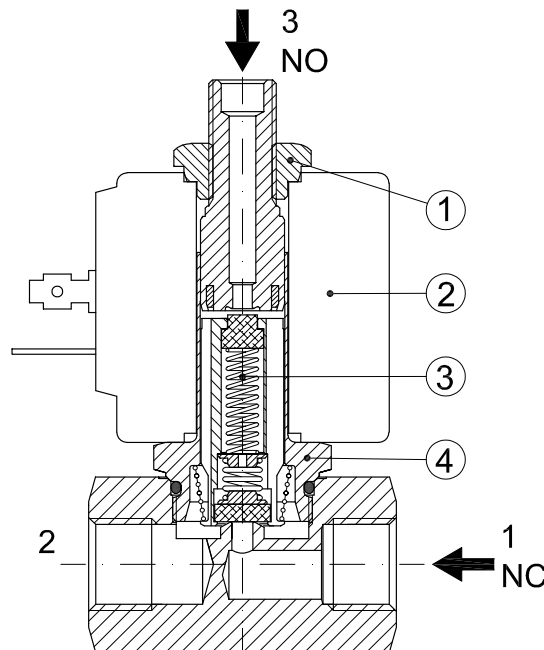

### OVERALL DIMENSION

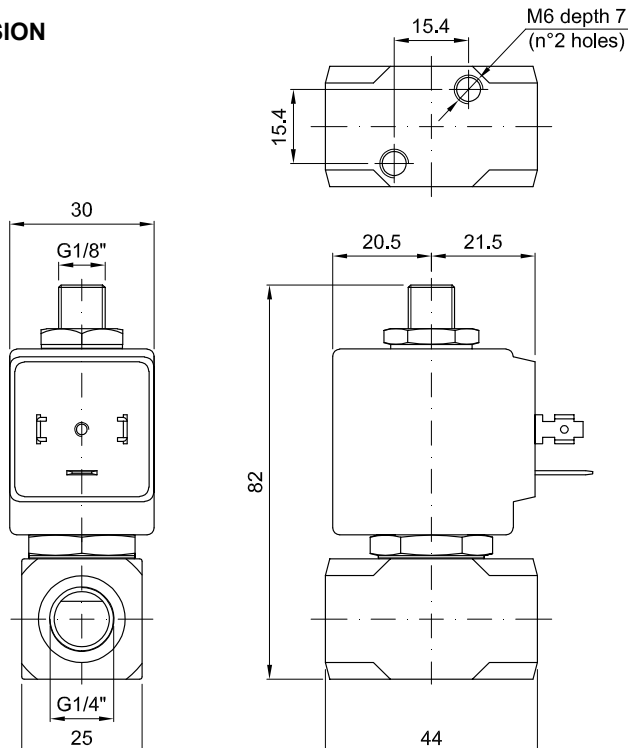

Weight=0.36Kg



**DESCRIPTION**

Solenoid valve 3 way  
direct acting poppet type

**CONSTRUCTION**

Body	Stainless steel
Armature tube	Stainless steel
Plunger and core	Stainless steel
Springs	Stainless steel
Seal material	NBR - FPM - EPDM



3

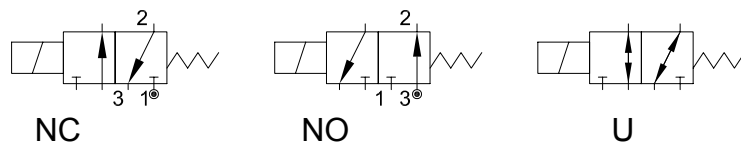

**FEATURES**

Maximum allowable pressure : maximum differential pressure +10%  
 Maximum fluid viscosity 25cSt (mm<sup>2</sup>/s)  
 Ambient temperature: with class F coil -10°C +55°C  
 with class H coil -10°C +80°C  
 Universal mounting position

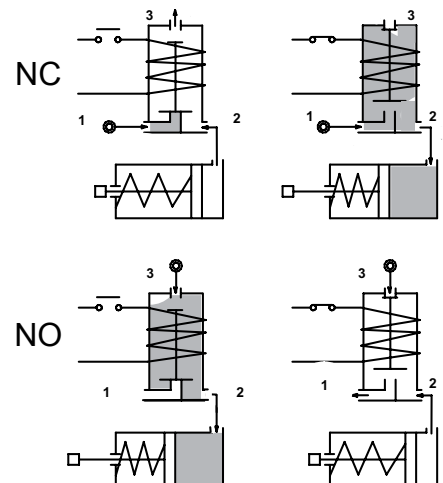

- OPTIONS:** Silver shading ring  
 Electroless nickel plating  
 Series 7 explosion proof coil according to ATEX - EExmII  
 Exhaust port with hosedtail connection  
 cULus certified coils

CODE ① ②	Connection G ISO 228	Orifice mm		Kv m <sup>3</sup> /h	Differential pressure bar			Nominal power			Coil		Seal ①	Temp. range °C
		Inlet	Exh.		Min	Max		AC	VA	DC	Series	Width		
<b>NC Normally closed</b>														
E311A...12///...	1/8"	1.2	1.5	0.04	0	15	15	12	8	6.5	3	22	NBR=B	-10 +90
E311A...15///...		1.5	1.5	0.06	0	10	10							
E311A...20///...		2	1.7	0.09	0	6	6							
<b>NO Normally open</b>														
E311A...15/S/...	1/8"	1.5	1.5	0.06	0	10	10	12	8	6.5	3	22	EPDM=E	-10 +140
E311A...17/S/...		1.7	2	0.07	0	6	6							
<b>U Universal</b>														
E311A...15/G/...	1/8"	1.5	1.5	0.06	0	6	6	12	8	6.5	3	22	FPM=V	-10 +140

- ① Seal  
 ② Coil

Example: E311AV15///30B FPM seal      Coil 24V 50/60Hz NC  
 E311AB15/S/301 NBR seal                      Coil 24V DC NO

COILS	Alternating Current 50/60Hz Volt							Direct Current Volt			Electrical connection	Connectors
	12	24	48	110	220 230	240	380	12	24	48		
Series 3 Width 22 Code ②	30A	30B	30C	30D	30E	30F	30G	300	301	302	DIN 46244	PG9 code 10348000

**DESCRIPTION**  
 Class F insulation  
 Voltage tolerance  
 AC +15% -10%  
 DC ± 10%  
 Protection class  
 IP65 with connector fitted  
 IP00 without connector  
 Continuous service ED100%

**OPTIONS**  
 Class H insulation  
 Cable attached  
 Special coil voltage  
 Special coil powers  
 CE certified coils

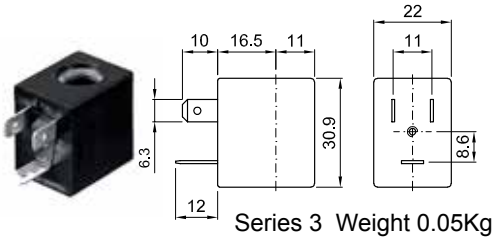

Series 3 Weight 0.05Kg

### SPARE PARTS LIST

1. Coil fixing nut
2. Coil
3. Plunger
4. Armature tube with core

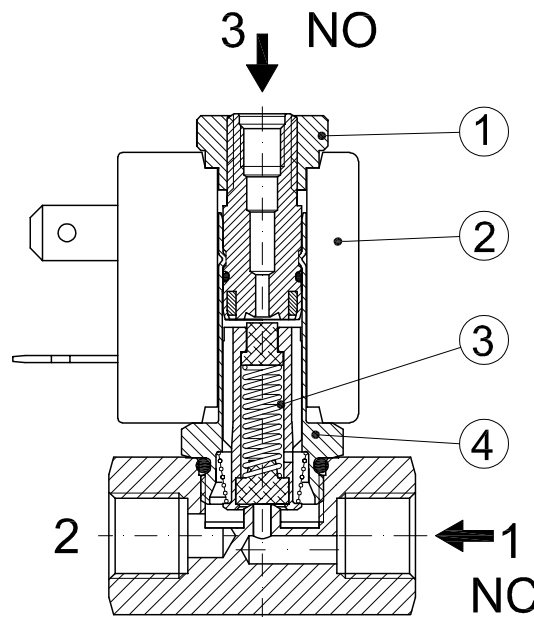

### OVERALL DIMENSION

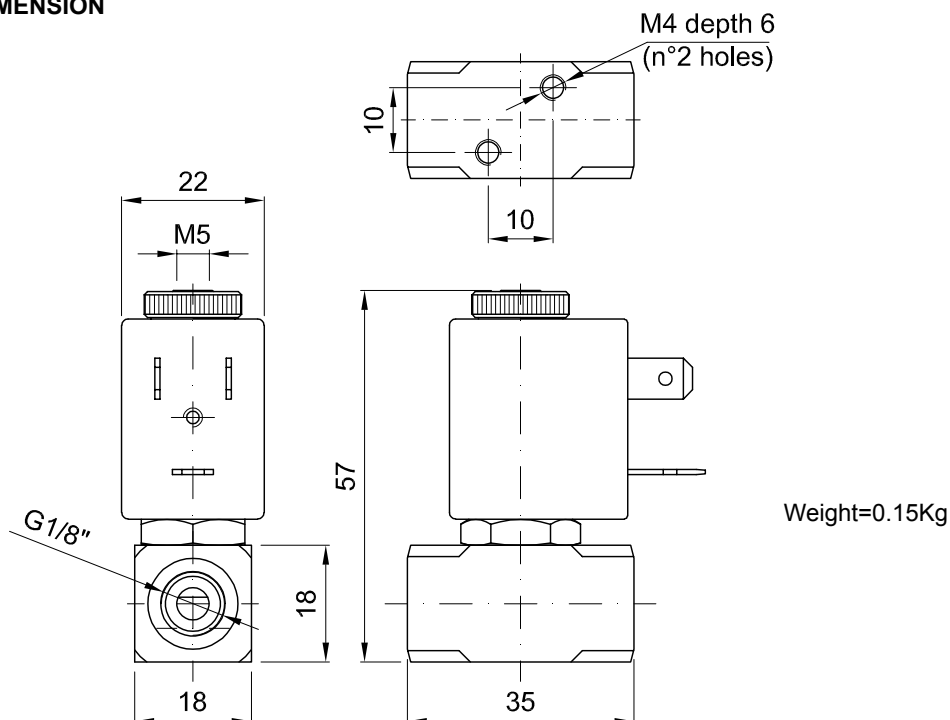

**DESCRIPTION**

Solenoid valve 3 way  
direct acting poppet type

**CONSTRUCTION**

Body	Brass
Armature tube	Brass
Plunger and core	Stainless steel
Springs	Stainless steel
Seal material	NBR - FPM - EPDM



**FEATURES**

Maximum allowable pressure : maximum differential pressure +10%  
 Maximum fluid viscosity 25cSt (mm<sup>2</sup>/s)  
 Ambient temperature: with class F coil -10°C +55°C  
 with class H coil -10°C +80°C  
 Universal mounting position

**OPTIONS:** Silver shading ring  
 Electroless nickel plating  
 Series 7 explosion proof coil according to ATEX - EExmII  
 Exhaust port with hosedtail connection  
 us certified coils

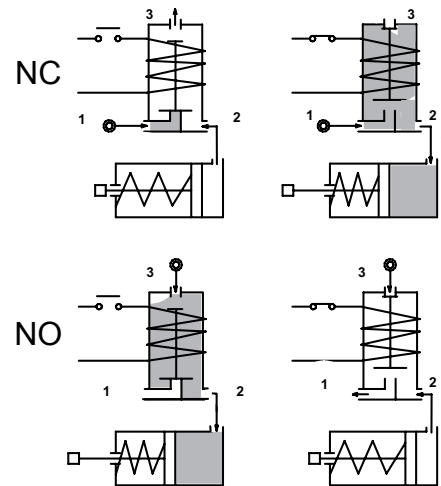
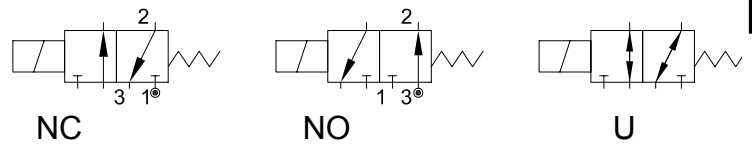

CODE ① ②	Flange	Orifice mm		Kv m <sup>3</sup> /h	Differential pressure bar			Nominal power			Coil		Seal ①	Temp. range °C
		Inlet	Exh.		Min	Max		AC	VA	DC	Series	Width		
<b>NC Normally closed</b>														
E312X...12///...	□ 25	1.2	1.5	0.04	0	15	15	12	8	6.5	3	22	NBR=B	-10 +90
E312X...15///...		1.5	1.7	0.06	0	10	10							
<b>NO Normally open</b>														
E312X...15/S/...	□ 25	1.5	1.5	0.06	0	10	10	12	8	6.5	3	22	EPDM=E	-10 +140
<b>U Universal</b>														
E312X...10/G/...	□ 25	1	1	0.028	0	10	10	12	8	6.5	3	22	FPM=V	-10 +140

① Seal Example: E312XV15///30B FPM seal Coil 24V 50/60Hz NC  
 ② Coil E312XB15/S/301 NBR seal Coil 24V DC NO

COILS	Alternating Current 50/60Hz Volt							Direct Current Volt			Electrical connection	Connectors
	12	24	48	110	220 230	240	380	12	24	48		
Series 3 Width 22 Code ②	30A	30B	30C	30D	30E	30F	30G	300	301	302	DIN 46244	PG9 code 10348000

**DESCRIPTION**  
 Class F insulation  
 Voltage tolerance  
 AC +15% -10%  
 DC ± 10%  
 Protection class  
 IP65 with connector fitted  
 IP00 without connector  
 Continuous service ED100%

**OPTIONS**  
 Class H insulation  
 Cable attached  
 Special coil voltage  
 Special coil powers  
 CE certified coils

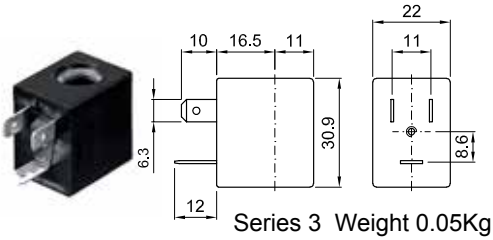

### SPARE PARTS LIST

1. Coil fixing nut
2. Coil
3. Plunger
4. Armature tube with core

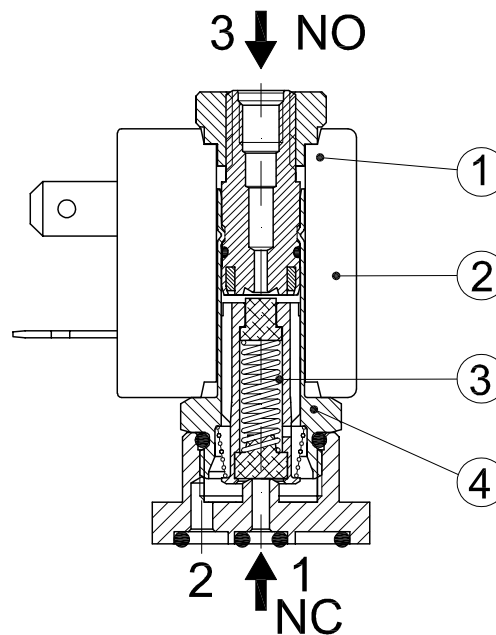

### OVERALL DIMENSION

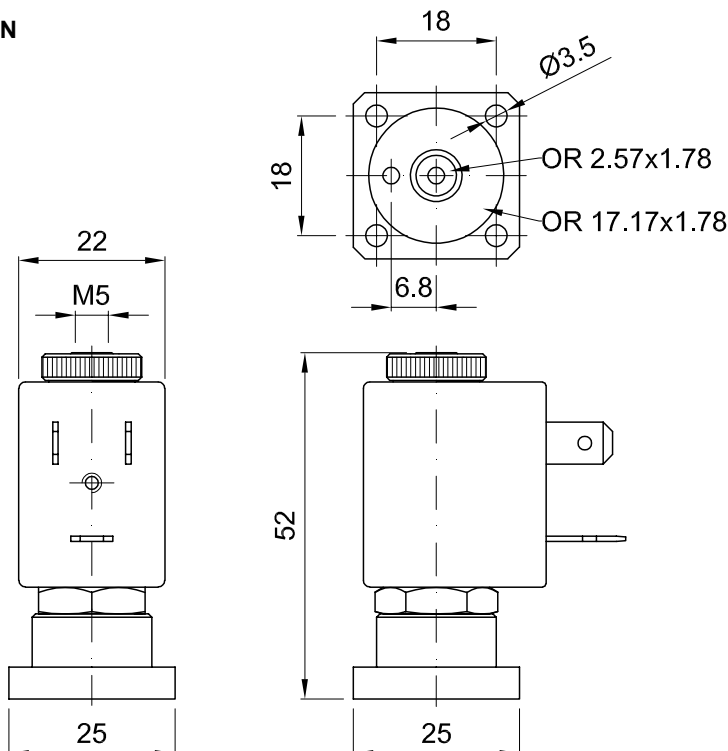

Weight=0.12Kg

**DESCRIPTION**

Solenoid valve 3 way normally open  
direct acting poppet type

**CONSTRUCTION**

Body	Brass
Armature tube	Brass
Plunger and core	Stainless steel
Springs	Stainless steel
Seal material	NBR - FPM - EPDM



**3**

**FEATURES**

Maximum allowable pressure : maximum differential pressure +10%  
 Maximum fluid viscosity 25cSt (mm<sup>2</sup>/s)  
 Ambient temperature: with class F coil -10°C +55°C  
 with class H coil -10°C +80°C  
 Universal mounting position

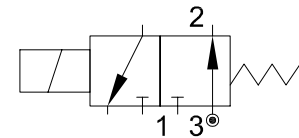

**OPTIONS:** Stainless steel armature tube  
 Electroless nickel plating  
 Series 7 explosion proof coil according to ATEX - EExmII  
 Exhaust port with hosedtail connection  
 c us certified coils

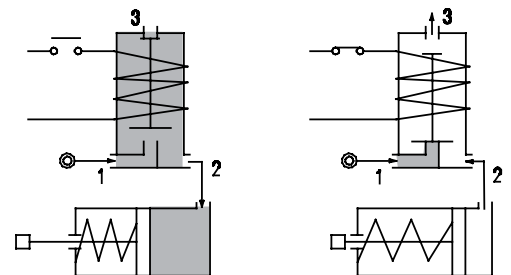

CODE ① ②	Flange	Orifice mm		Kv m <sup>3</sup> /h	Differential pressure bar			Nominal power			Coil		Seal ①	Temp. range °C
		Inlet	Exh.		Min	Max		AC Inrush	VA Holding	DC Watt	Series	Width		
E313X...12///...	□ 25	1.2	1.2	0.04	0	12	8	12	8	6.5	3	22	NBR=B EPDM=E FPM=V	-10 +90
E313X...15///...		1.5	1.2	0.06	0	9	6							-10 +140 -10 +140

① Seal Example: E313XV15///301 FPM seal  
 ② Coil Coil 24V DC

COILS	Alternating Current 50/60Hz Volt							Direct Current Volt			Electrical connection	Connectors
	12	24	48	110	220 230	240	380	12	24	48		
Series 3 Width 22 Code ②	30A	30B	30C	30D	30E	30F	30G	300	301	302	DIN 46244	PG9 code 10348000

**DESCRIPTION**  
 Class F insulation  
 Voltage tolerance  
 AC +15% -10%  
 DC ± 10%  
 Protection class  
 IP65 with connector fitted  
 IP00 without connector  
 Continuous service ED100%

**OPTIONS**  
 Class H insulation  
 Cable attached  
 Special coil voltage  
 Special coil powers  
 cULus certified coils

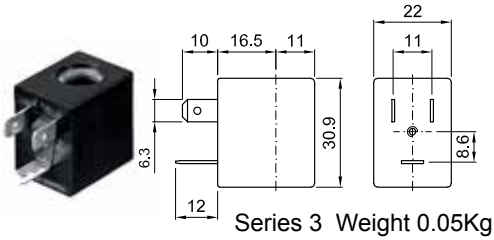

Series 3 Weight 0.05Kg

### SPARE PARTS LIST

1. Coil fixing nut
2. Coil
3. Seal assembly
4. Armature tube with core

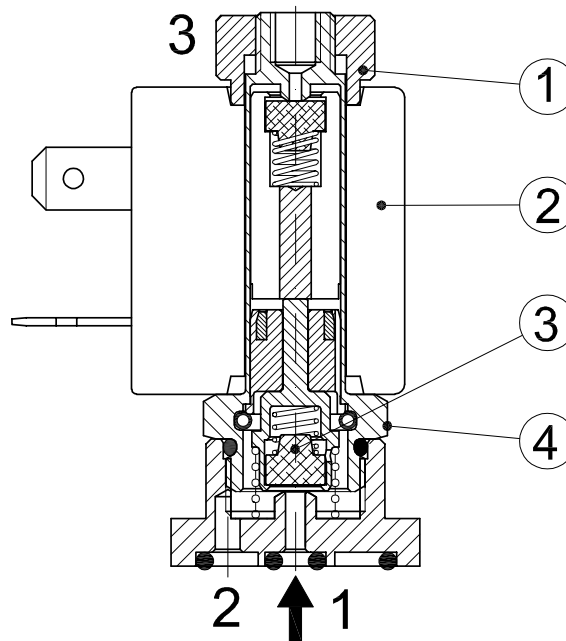

### OVERALL DIMENSION

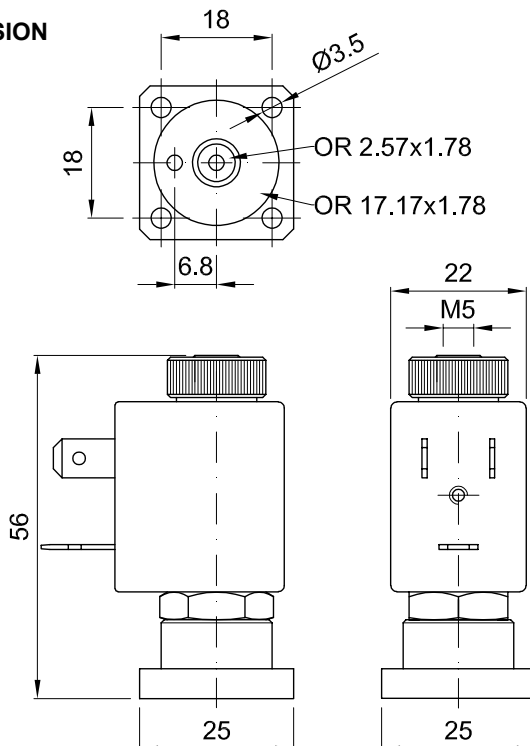

Weight=0.12Kg

## DESCRIPTION

Solenoid valve 3 way  
direct acting poppet type

## CONSTRUCTION

Body	Brass
Armature tube	Stainless steel
Plunger and core	Stainless steel
Springs	Stainless steel
Seal material	NBR - FPM - EPDM



# 3

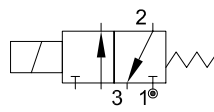

NC

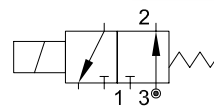

NO

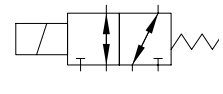

U

## FEATURES

Maximum allowable pressure : maximum differential pressure +10%  
 Maximum fluid viscosity 25cSt (mm<sup>2</sup>/s)  
 Ambient temperature: with class F coil -10°C +55°C  
 with class H coil -10°C +80°C  
 Universal mounting position

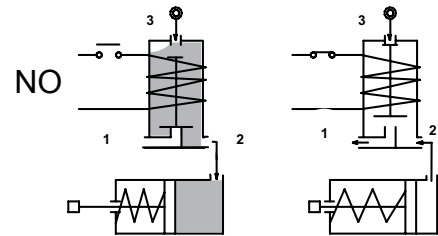
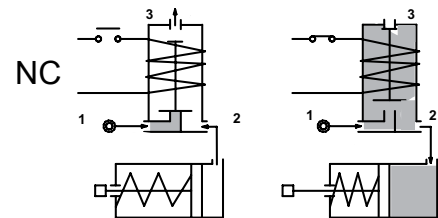

**OPTIONS:** Manual override  
 Electroless nickel plating  
 Stainless steel seat  
 c us certified coils

CODE ① ②	Flange	Orifice mm		Kv m <sup>3</sup> /h	Differential pressure bar			Nominal power			Coil		Seal ①	Temp. range °C
		Inlet	Exh.		Min	Max AC DC		AC Inrush	VA Holding	DC Watt	Series	Width		
<b>NC Normally closed</b>														
E314X...15///...	□ 32	1.5	2.4	0.07	0	20	20	20	15	10	2	30	NBR=B	-10 +90
E314X...20///...		2	2.4	0.11	0	13	13							
E314X...25///...		2.5	2.4	0.16	0	10	10							
<b>NO Normally open</b>														
E314X...24/S/...	□ 32	2.4	2.5	0.16	0	9	9	20	15	10	2	30	EPDM=E	-10 +140
E314X...29/S/...		2.9	3	0.20	0	6.5	6.5							
<b>U Universal</b>														
E314X...25/G/...	□ 32	2.5	2.4	0.16	0	5	4	20	15	10	2	30	FPM=V	-10 +140

① Seal  
 ② Coil  
 Example: E314XV15///20B FPM seal Coil 24V 50/60Hz NC  
 E314XB24/S/201 NBR seal Coil 24V DC NO

COILS	Alternating Current 50/60Hz Volt							Direct Current Volt			Electrical connection	Connectors
	12	24	48	110	220 230	240	380	12	24	48		
Series 2 Width 30 Code ②	20A	20B	20C	20D	20E	20F	20G	200	201	202	DIN 43650A	PG9 code 10349000

**DESCRIPTION**  
 Insulation class  
 Series 2 =F Series 5=H  
 Voltage tolerance  
 AC +15% -10%  
 DC ± 10%  
 Protection class  
 IP65 with connector fitted  
 IP00 without connector  
 Continuous service ED100%

**OPTIONS**  
 Class H insulation (series 2)  
 Cable attached  
 Special coil voltage  
 Special coil powers  
 cULus certified coils

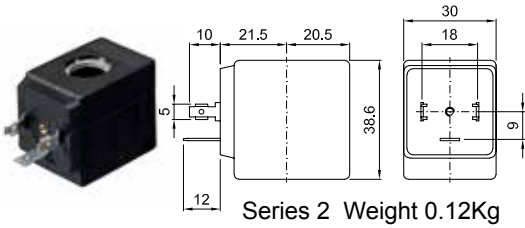

Series 2 Weight 0.12Kg

### SPARE PARTS LIST

1. Coil fixing nut
2. Coil
3. Plunger
4. Armature tube with core

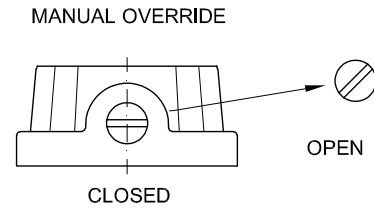
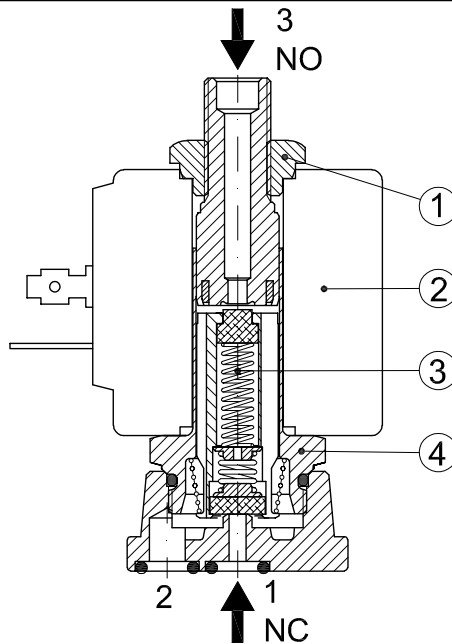

### OVERALL DIMENSION

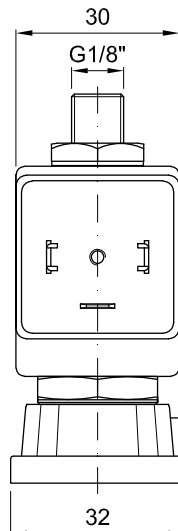
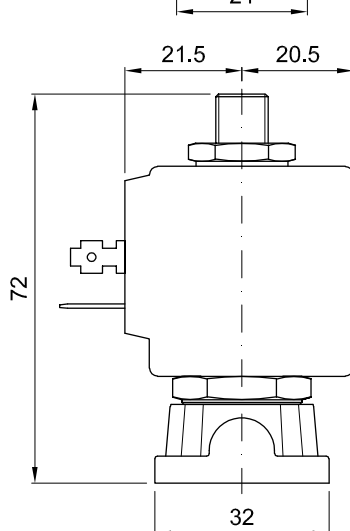
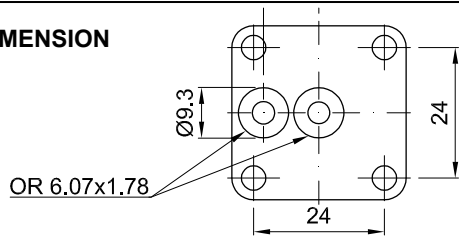

Weight=0.32Kg



### DESCRIPTION

Solenoid valve 3 way direct acting poppet type.  
The balanced seal and the special construction allows a big flow.  
The solenoid valve can be used as normally closed, normally open, mixer or diverter.

### CONSTRUCTION

Body	Anodized aluminium (320,321,322) Stainless steel (323,324,325)
Armature tube	Stainless steel
Plunger and core	Stainless steel
Springs	Stainless steel
Seal material	FPM

**3**

### FEATURES

Maximum allowable pressure : maximum differential pressure +10%

Maximum fluid viscosity 25cSt (mm<sup>2</sup>/s)

Ambient temperature: with class F coil -10°C +55°C  
with class H coil -10°C +80°C

Universal mounting position

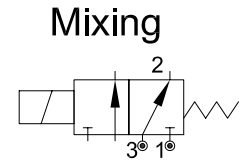
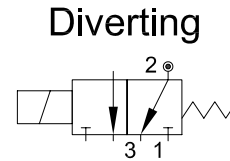
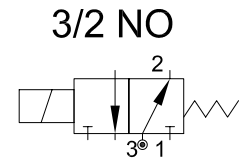
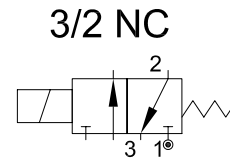

CODE ① ②	Connection G ISO 228	Orifice mm		Kv m <sup>3</sup> /h	Differential pressure bar			Nominal power			Coil		Seal ①	Temp. range °C		
		Inlet	Exh.		Min	Max		AC Inrush	VA Holding	DC Watt	Series	Width				
<b>ANODIZED ALUMINIUM BODY</b>																
<b>Universal</b>																
E320BV75///...	G1/4"	7.5	7.5	0.64	0	5	5	40	30	27	5	36	FPM=V	-10 +140		
<b>NC Normally closed</b>																
E321BV75///...	G1/4"	7.5	7.5	0.64	0	9	9	40	30	27	5	36				
<b>NO Normally open</b>																
E322BV75///...	G1/4"	7.5	7.5	0.64	0	9	9	40	30	27	5	36				

<b>STAINLESS STEEL BODY</b>																
<b>Universal</b>																
E323BV75///...	G1/4"	7.5	7.5	0.64	0	5	5	40	30	27	5	36	FPM=V	-10 +140		
<b>NC Normally closed</b>																
E324BV75///...	G1/4"	7.5	7.5	0.64	0	9	9	40	30	27	5	36				
<b>NO Normally open</b>																
E325BV75///...	G1/4"	7.5	7.5	0.64	0	9	9	40	30	27	5	36				

① Seal  
② Coil

Example: E320BV75///521 Universal FPM seal Coil 24V DC

COILS	Alternating Current 50/60Hz Volt							Direct Current Volt			Electrical connection	Connectors
	12	24	48	110	220 230	240	380	12	24	48		
Series 5 Width 36 Code ②	52A	52B	52C	52D	52E	52F	52G	520	521	522	DIN 43650A	PG11 code 10349001

**DESCRIPTION**  
 Class H insulation  
 Voltage tolerance  
 AC +15% -10%  
 DC ± 10%  
 Protection class  
 IP65 with connector fitted  
 IP00 without connector  
 Continuous service ED100%

**OPTIONS**  
 Cable attached  
 Special coil voltage  
 Special coil powers

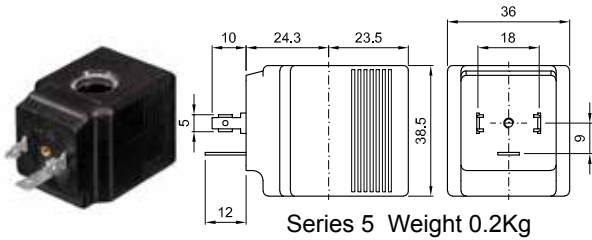

Series 5 Weight 0.2Kg

### SPARE PARTS LIST

1. Coil fixing nut
2. Coil
3. Armature tube with core

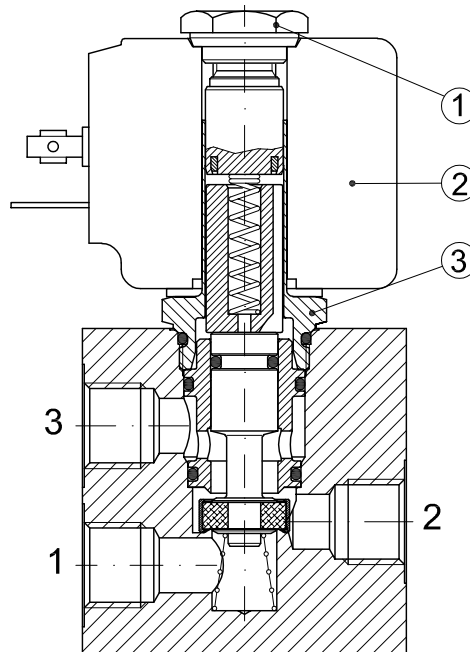

### OVERALL DIMENSION

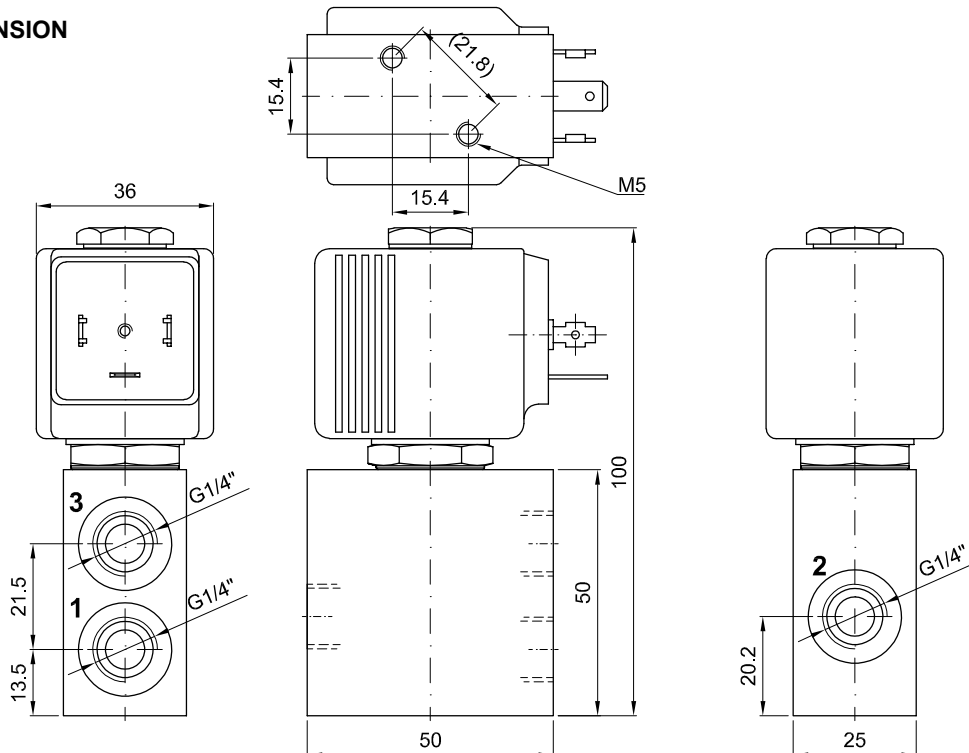

Weight=0.43Kg

**DESCRIPTION**

Solenoid valve 3 way direct acting with dry armature.  
No metal parts in contact with the media.

**CONSTRUCTION**

Body Acetal copolymer  
Seal material NBR



**3**

**FEATURES**

Maximum allowable pressure 0,5bar  
Maximum fluid viscosity 25cSt (mm<sup>2</sup>/s)  
Ambient temperature -10°C +45°C  
Maximum fluid temperature +50°C  
Universal mounting position

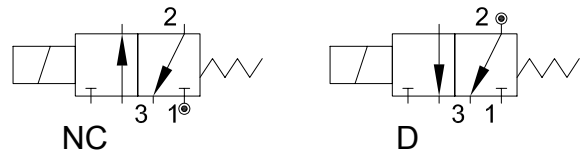

**ELECTRICAL OPERATING FEATURES**

Duty cycle ED100%  
Insulation class F  
Voltage tolerance ±5%  
Protection class IP65 with connectore fitted

CODE ①	Hosetail connection	Orifice mm	Kv m <sup>3</sup> /h	Differential pressure bar		Nominal power			Voltage		Connector
				Min	Max	AC Inrush	VA Holding	DC Watt	AC	DC	
E330PB32/.../106620	Ø5.5	3.2	0.2	0	0.4	6.5	4.5	-	230	-	PG7 10348040
D330PB32/.../111140	Ø5.5	3.2	0.2	0	0.4	-	-	4	-	12	
D330PB32/.../111150	Ø5.5	3.2	0.2	0	0.4	-	-	4	-	47	

① Configuration Example: D330PB32///111140 3/2 NC Coil 24V DC  
D330PB32/D/111140 Diverting Coil 24V D

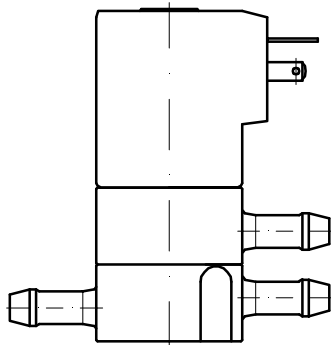

code **///**  
3/2 NC

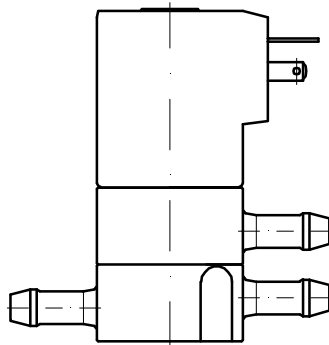

code **/D/**  
DIVERTING

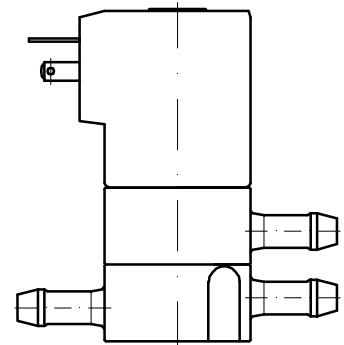

code **/R/**

**SPARE PARTS LIST**

- 1. Coil
- 2. Diaphragm

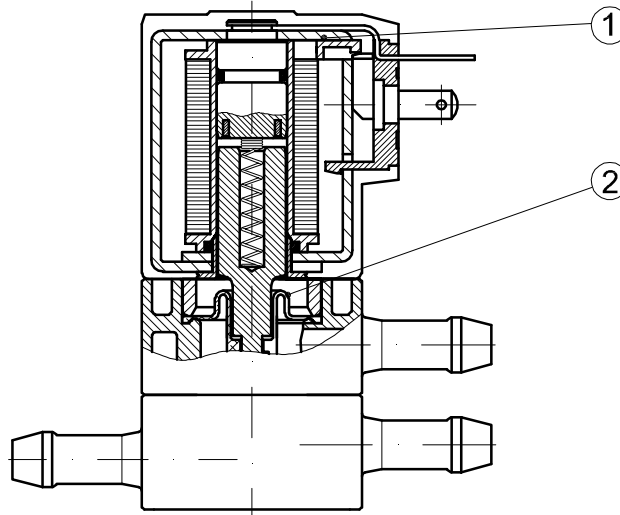

**OVERALL DIMENSION**

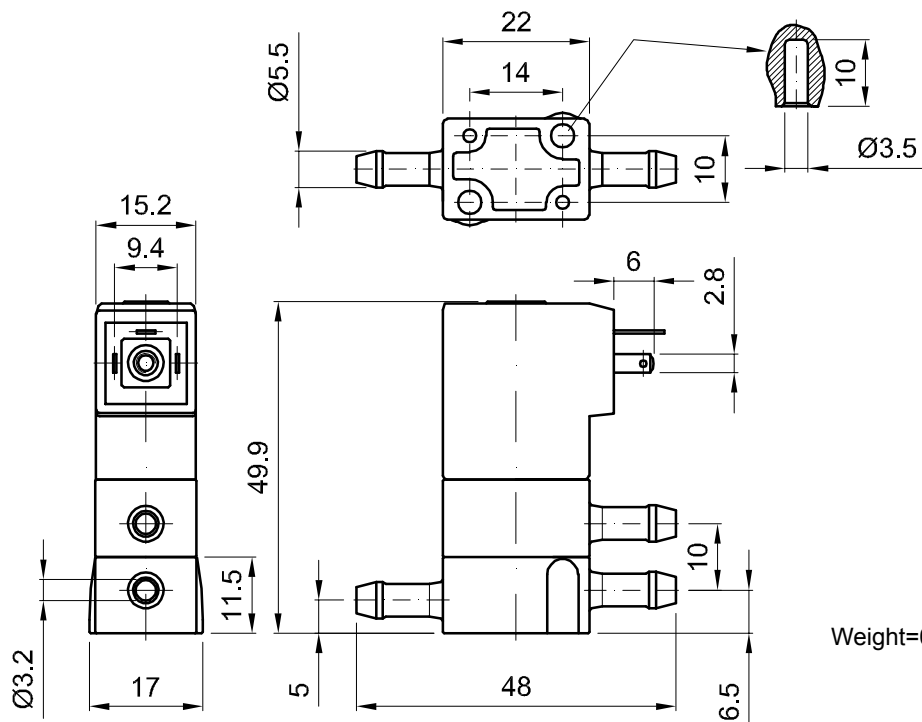

Weight=0.04Kg

**DESCRIPTION**

Solenoid valve 3 way normally closed direct acting poppet type, suitable for food applications and all compatible fluids.

**CONSTRUCTION**

Body	Thermoplastic polymer NSF, WRC, KTW, FDA certified
Armature tube	Brass chemically nickel plated
Plunger and core	Stainless steel
Springs	Stainless steel
Seal material	NBR - FPM - EPDM (food contact certified)



**3**

**FEATURES**

Maximum allowable pressure 10bar  
 Maximum fluid viscosity 25cSt (mm<sup>2</sup>/s)  
 Ambient temperature: with class F coil -10°C +55°C  
 with class H coil -10°C +80°C  
 Universal mounting position

**OPTIONS:** Stainless steel armature tube  
 Type N connection without nut  
 c us certified coils

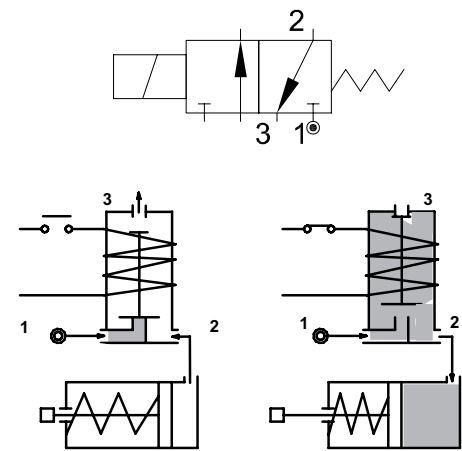

CONNECTION					
K	N	P	W	Y	Z
<b>SPIGGOT</b>	<b>G1/8" male thread with NUT for flexible pipes</b>	<b>HOSETAIL for flexible pipes</b>	<b>COMPRESSION for flexible and semiflexible pipes</b>	<b>PUSH IN for semiflexible pipes Øext 6</b>	<b>PUSH IN for semiflexible pipes Øext 4</b>

CODE ① ②	Connection *	Orifice mm	Kv m <sup>3</sup> /h	Differential pressure bar			Nominal power			Coil		Seal ①	Temp. range** °C
				Min	Max		AC Inrush	VA Holding	DC Watt	Series	Width		
					AC	DC							
<b>E335*...15///...</b>	<b>K-N-P-W-Y-Z</b>	<b>1.5</b>	<b>0.06</b>	<b>0</b>	<b>9</b>	<b>9</b>	<b>12</b>	<b>8</b>	<b>6.5</b>	<b>3</b>	<b>22</b>	<b>NBR=A</b> <b>EPDM=E</b> <b>FPM=V</b>	<b>-10 +90</b> <b>-10 +140</b> <b>-10 +140</b>

① Seal Example: E335KA15///30B NBR seal SPIGGOT connection  
 ② Coil Coil 24V 50/60Hz  
 ③ Only for connection "W" E335W.../1/...

\*\* The temperature range is related to the material of the seals (NBR, EPDM, FPM), and the valves' body. Please contact us concerning the temperature range referred to the different types of connection.

COILS	Alternating Current 50/60Hz Volt							Direct Current Volt			Electrical connection	Connectors
	12	24	48	110	220 230	240	380	12	24	48		
Series 3 Width 22 Code ②	30A	30B	30C	30D	30E	30F	30G	300	301	302	DIN 46244	PG9 code 10348000

**DESCRIPTION**  
 Class F insulation  
 Voltage tolerance  
 AC +15% -10%  
 DC ± 10%  
 Protection class  
 IP65 with connector fitted  
 IP00 without connector  
 Continuous service ED100%

**OPTIONS**  
 Class H insulation  
 Cable attached  
 Special coil voltage  
 Special coil powers  
 CE certified coils

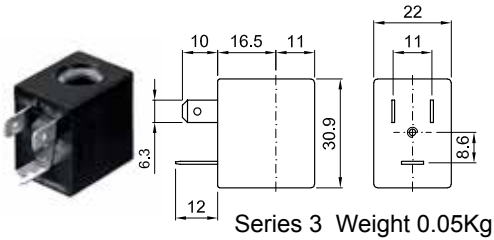

### SPARE PARTS LIST

1. Coil fixing nut
2. Coil
3. Plunger
4. Armature tube with core

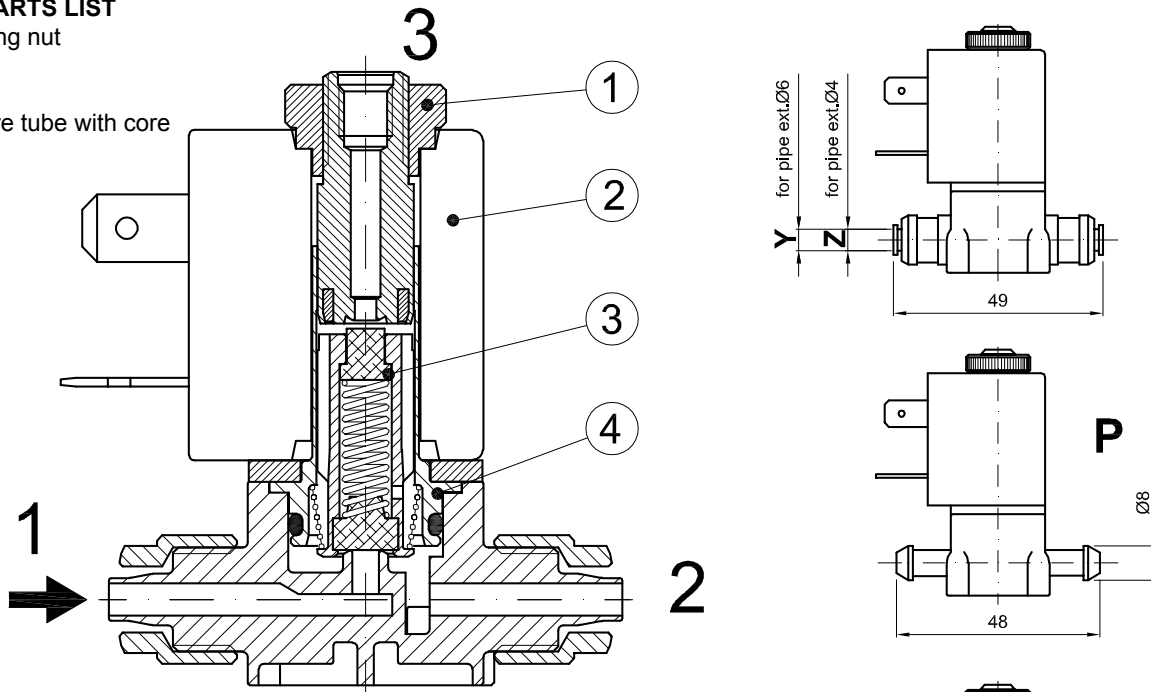

Weight=0.10Kg

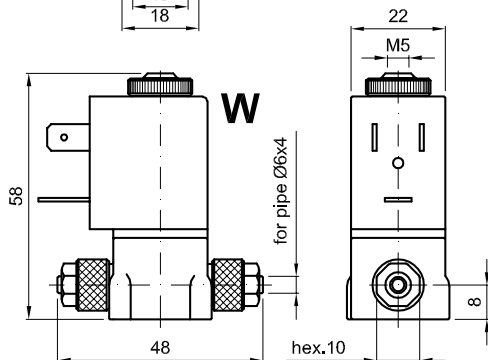
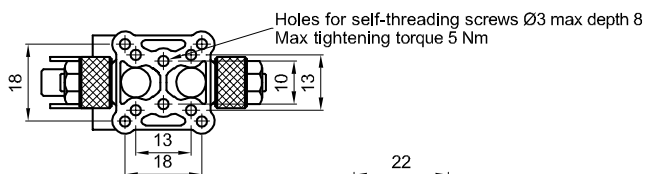

Nut max torque 2Nm

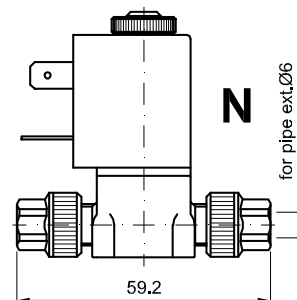
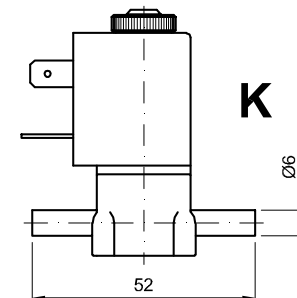
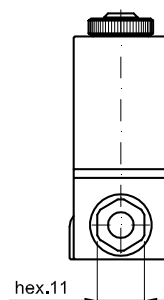

Screw the nut with wrench 11 up to the sliding on the hexagon (torque limiting device)

**DESCRIPTION**

Solenoid valve 3 way normally open direct acting poppet type, suitable for food applications and all compatible fluids.

**CONSTRUCTION**

Body	Thermoplastic polymer NSF, WRC, KTW, FDA certified
Armature tube	Brass
Plunger and core	Stainless steel
Springs	Stainless steel
Seal material	NBR - FPM - EPDM (food contact certified)



**3**

**FEATURES**

- Maximum allowable pressure 10bar
- Maximum fluid viscosity 25cSt (mm<sup>2</sup>/s)
- Ambient temperature: with class F coil -10°C +55°C  
with class H coil -10°C +80°C
- Universal mounting position

- OPTIONS:** Stainless steel armature tube  
Chemically nickel-plated armature tube  
Type N connection without nut  
c us certified coils

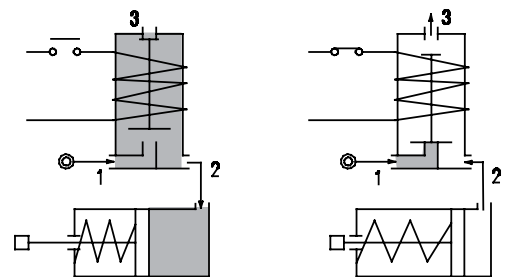
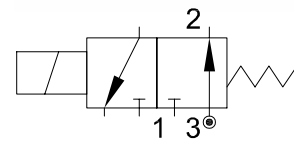

CONNECTION					
K	N	P	W	Y	Z
<b>SPIGGOT</b>	<b>G1/8" male thread with NUT for flexible pipes</b>	<b>HOSETAIL for flexible pipes</b>	<b>COMPRESSION for flexible and semiflexible pipes</b>	<b>PUSH IN for semiflexible pipes Øext 6</b>	<b>PUSH IN for semiflexible pipes Øext 4</b>

CODE ① ②	Connection *	Orifice mm	Kv m <sup>3</sup> /h	Differential pressure bar		Nominal power			Coil		Seal ①	Temp. range** °C	
				Min	Max	AC Inrush	VA Holding	DC Watt	Series	Width			
<b>E337*...15///...</b>	<b>K-N-P-W-Y-Z</b>	<b>1.5</b>	<b>0.06</b>	<b>0</b>	<b>9</b>	<b>6</b>	<b>12</b>	<b>8</b>	<b>6.5</b>	<b>3</b>	<b>22</b>	<b>NBR=A EPDM=E FPM=V</b>	<b>-10 +90 -10 +140 -10 +140</b>

- ① Seal
  - ② Coil
  - ③ Only for connection "W"
- Example: E337KA15///30B NBR seal SPIGGOT connection  
Coil 24V 50/60Hz  
E337W.../1/...

\*\* The temperature range is related to the material of the seals (NBR, EPDM, FPM), and the valves' body. Please contact us concerning the temperature range referred to the different types of connection.

COILS	Alternating Current 50/60Hz Volt							Direct Current Volt			Electrical connection	Connectors
	12	24	48	110	220 230	240	380	12	24	48		
Series 3 Width 22 Code ②	30A	30B	30C	30D	30E	30F	30G	300	301	302	DIN 46244	PG9 code 10348000

**DESCRIPTION**  
 Class F insulation  
 Voltage tolerance  
 AC +15% -10%  
 DC ± 10%  
 Protection class  
 IP65 with connector fitted  
 IP00 without connector  
 Continuous service ED100%

**OPTIONS**  
 Class H insulation  
 Cable attached  
 Special coil voltage  
 Special coil powers  
 CE certified coils

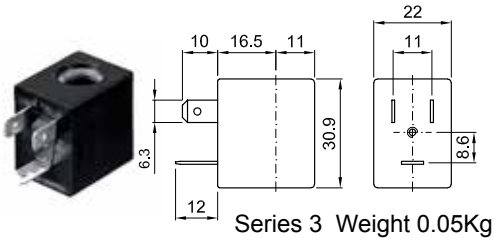

Series 3 Weight 0.05Kg

### SPARE PARTS LIST

1. Coil fixing nut
2. Coil
3. Seal assembly with core
4. Armature tube with core

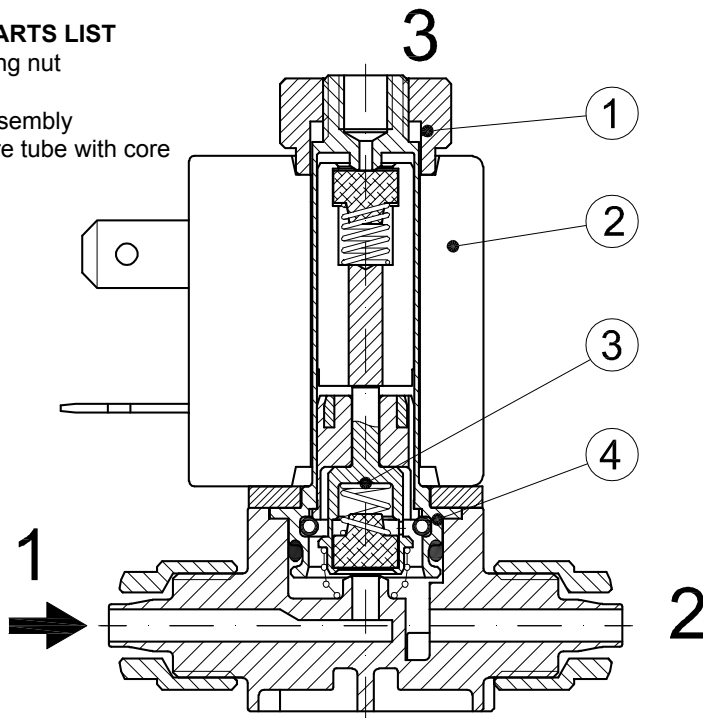

Weight=0.10Kg

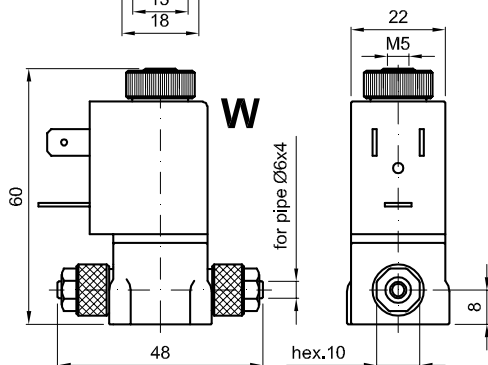
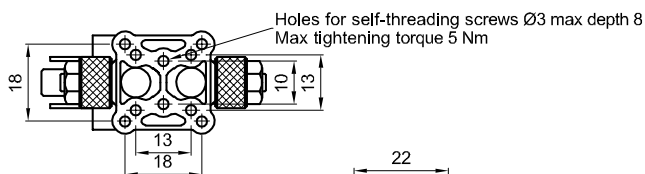

Nut max torque 2Nm

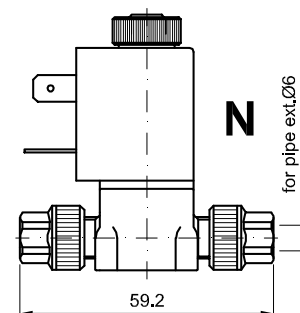
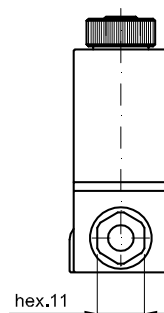
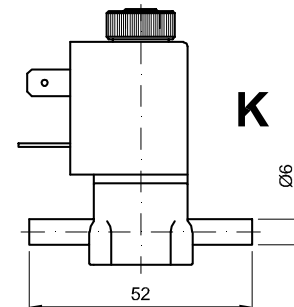
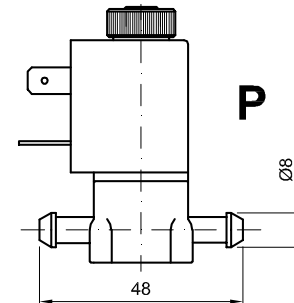
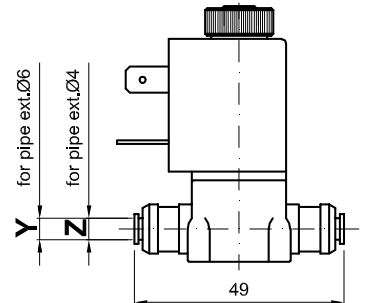

Screw the nut with wrench 11 up to the sliding on the hexagon (torque limiting device)



**DESCRIPTION**

Solenoid valve 3 way  
direct acting poppet type

**CONSTRUCTION**

Body Acetal copolymer  
Internal parts Acetal copolymer - Stainless steel  
Seal material NBR



**FEATURES**

Fixing method: M3 screws  
max torque 0,5Nm

Universal mounting position

Fluid temperature: +50°C max  
Ambient temperature: -15°C +50°C  
Fluid: Air, neutral gases  
Response time: 10-15ms  
Manual override: Enclosed bi-stable function

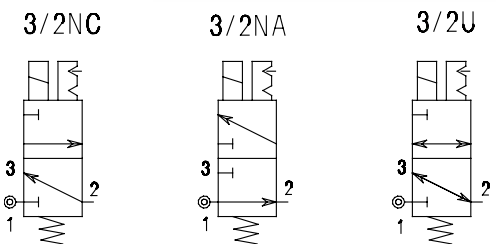

**3**

**ELECTRICAL OPERATING FEATURES**

Duty cycle: ED100%  
Insulation class: F (+155°C)  
Voltage tolerance: ±10%  
Protection class: Cables IP65  
Fast-on IP00, with connector fitted IP65

Electrical connection: Cables (L=300mm)  
AMP 2.8x0.5  
DIN 43650C

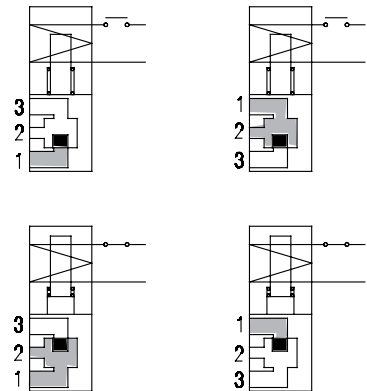

Connection	Orifice mm		Nominal rate NI/1' ΔP=1bar	Differential pressure bar		Nominal power			CODE	
	1→2	2→3		Min	Max	AC Inrush	VA Holding	DC Watt	Alternating current	Direct current
<b>NC Normally closed</b>										
Flange	0.8	0.9	23	0	10	-	-	1.5	E340XB08	D340XB08
	1.2	1.3	29	0	10	3.6	2.5	2.5	E340XB12	D340XB12
	1.5	1.6	43	0	6	3.6	2.5	2.5	E340XB15	D340XB15
<b>NO Normally open</b>										
Flange	1	1.2	26	0	8	3.6	2.5	2.5	E341XB10	D341XB10
	1	1.2	26	0	8	3.6	2.5	2.5	E343XB10	D343XB10
<b>U Universal</b>										
Flange	1.5	1.6	43	0	2.5	3.6	2.5	2.5	E342XB15	D342XB15

**COIL CODE**

VOLTAGE	AMP 2.8x0.5			DIN 43650 form C			CABLE		
	50/60Hz	1.5W DC	2.5W DC	50/60Hz	1.5W DC	2.5W DC	50/60Hz	1.5W DC	2.5W DC
12	-	106970	106950	-	109020	109040	-	107010	106990
24	107030	106980	106960	108990	109030	109050	107040	107020	107000
110	107060	-	-	109000	-	-	-	-	-
220/230	107050	-	-	109010	-	-	-	-	-

P.S. 1,5W power available on Ø0.8 orifice only.

### CONNECTIONS

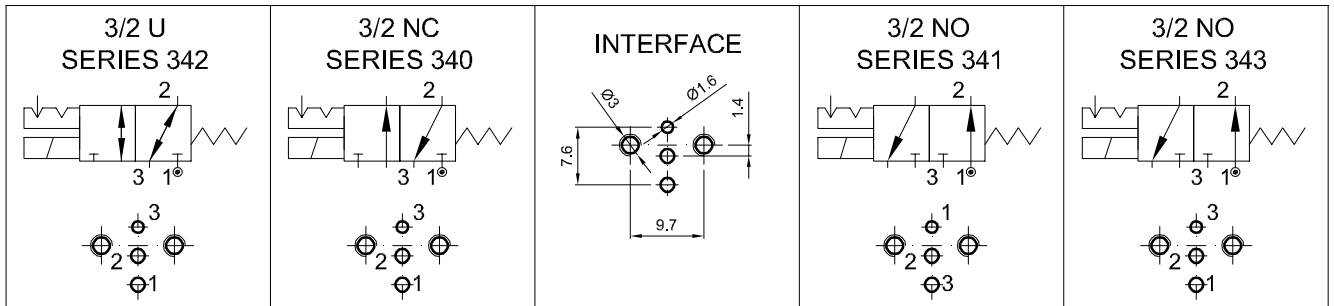

### OVERALL DIMENSION

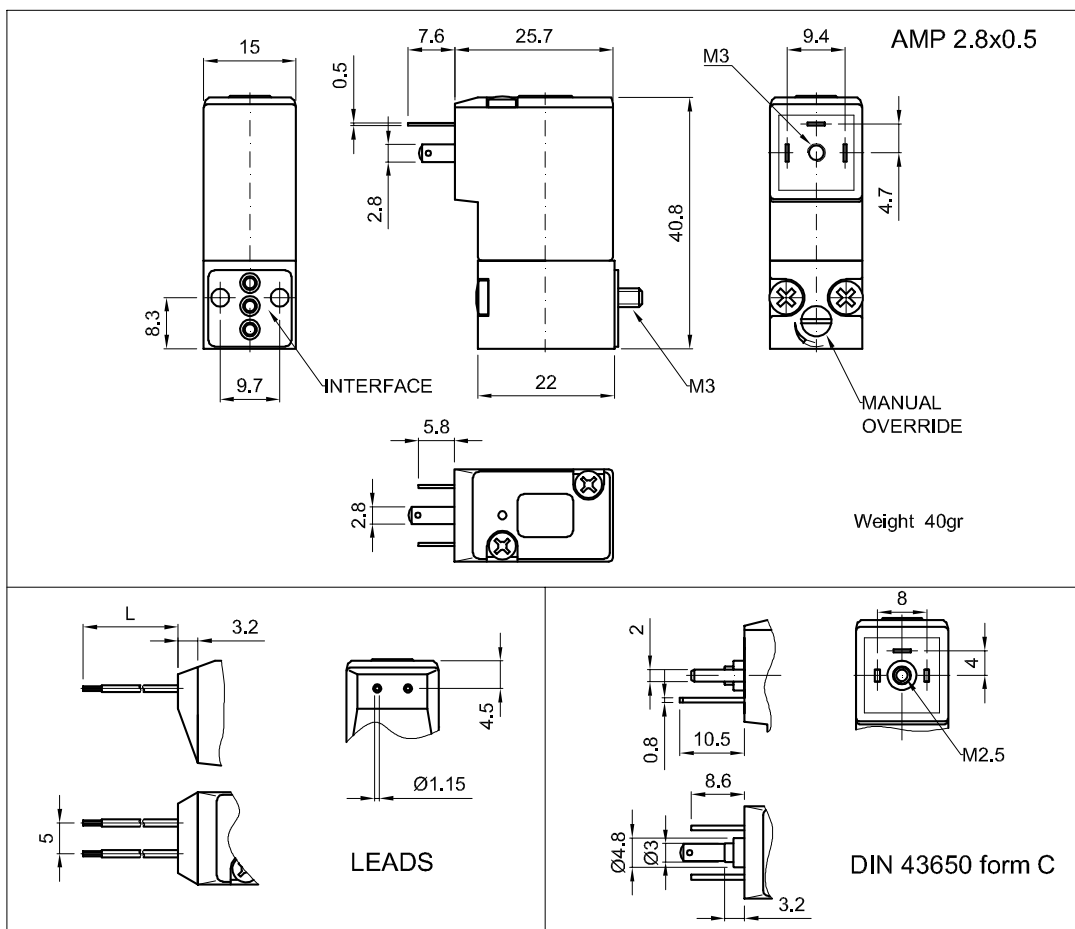

### TYPE NUMBER COMPOSITION

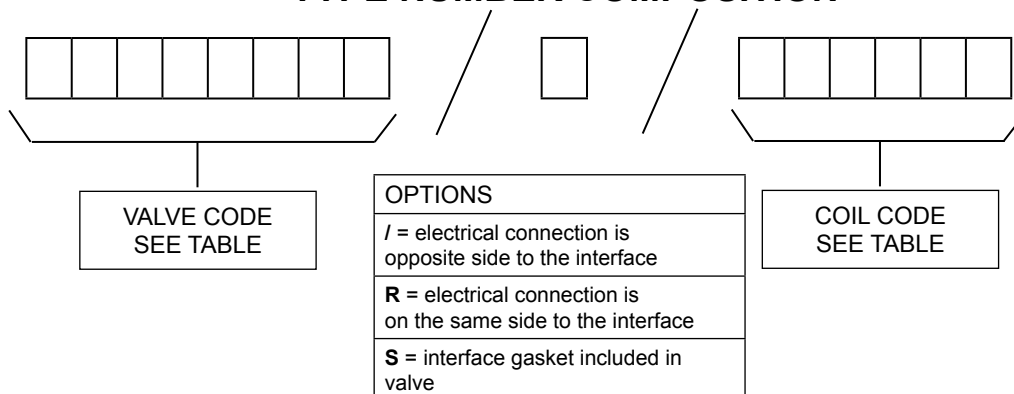

**DESCRIPTION**

Solenoid valve 3 way  
direct acting poppet type

**CONSTRUCTION**

Body Acetal copolymer  
Internal parts Acetal copolymer - Stainless steel  
Seal material NBR



**FEATURES**

Fixing method: M2.5 screws  
max torque 0,5Nm

Universal mounting position

Fluid temperature: +50°C max  
Ambient temperature: -15°C +50°C  
Fluid: Air, neutral gases  
Response time: 10-15ms  
Manual override: Enclosed bi-stable function

**ELECTRICAL OPERATING FEATURES**

Duty cycle: ED100%  
Insulation class: F (+155°C)  
Voltage tolerance: ±10%  
Protection class: Cables IP65  
Fast-on IP00, with connector fitted IP65

Electrical connection: Cables (L=300mm)  
AMP 2.8x0.5  
DIN 43650C

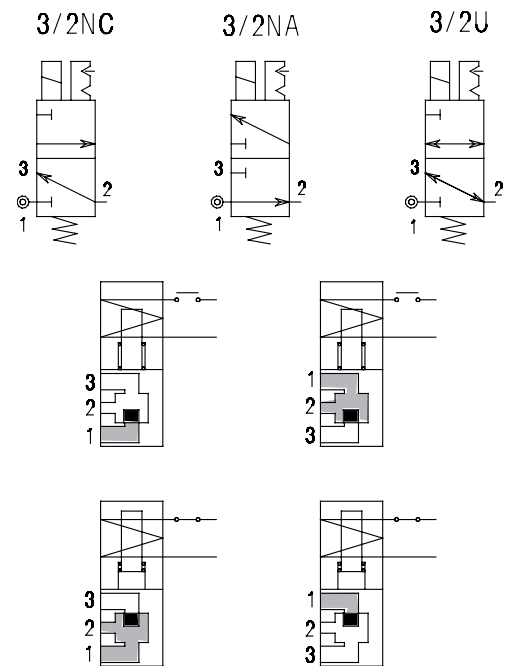

**3**

Connection	Orifice mm		Nominal rate NI/1' ΔP=1bar	Differential pressure bar		Nominal power			CODE	
	1→2	2→3		Min	Max	AC Inrush	VA Holding	DC Watt	Alternating current	Direct current
<b>NC Normally closed</b>										
Flange	0.8	0.9	23	0	10	-	-	1.5	E345XB08	D345XB08
	1.2	1.3	29	0	10	3.6	2.5	2.5	E345XB12	D345XB12
	1.5	1.6	43	0	6	3.6	2.5	2.5	E345XB15	D345XB15
<b>NO Normally open</b>										
Flange	1	1.2	26	0	8	3.6	2.5	2.5	E346XB10	D346XB10
	1	1.2	26	0	8	3.6	2.5	2.5	E346XB10	D346XB10
<b>U Universal</b>										
Flange	1.5	1.6	43	0	2.5	3.6	2.5	2.5	E347XB15	D347XB15

**COIL CODE**

VOLTAGE	AMP 2.8x0.5			DIN 43650 form C			CABLE		
	50/60Hz	1.5W DC	2.5W DC	50/60Hz	1.5W DC	2.5W DC	50/60Hz	1.5W DC	2.5W DC
12	-	106970	106950	-	109020	109040	-	107010	106990
24	107030	106980	106960	108990	109030	109050	107040	107020	107000
110	107060	-	-	109000	-	-	-	-	-
220/230	107050	-	-	109010	-	-	-	-	-

P.S. 1,5W power available on Ø0.8 orifice only.

### CONNECTIONS

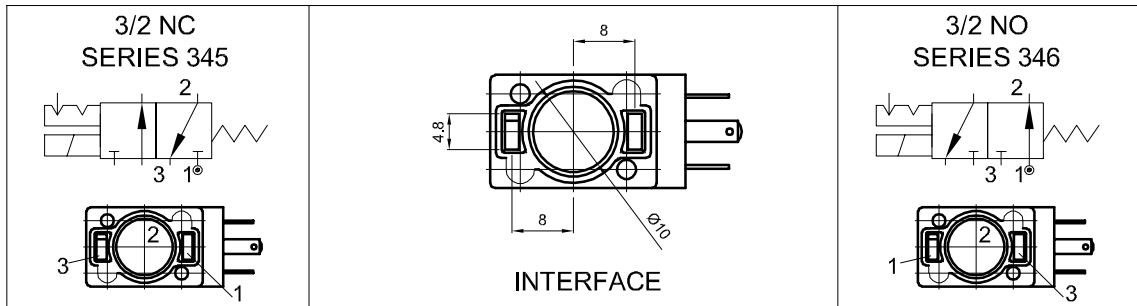

### OVERALL DIMENSION

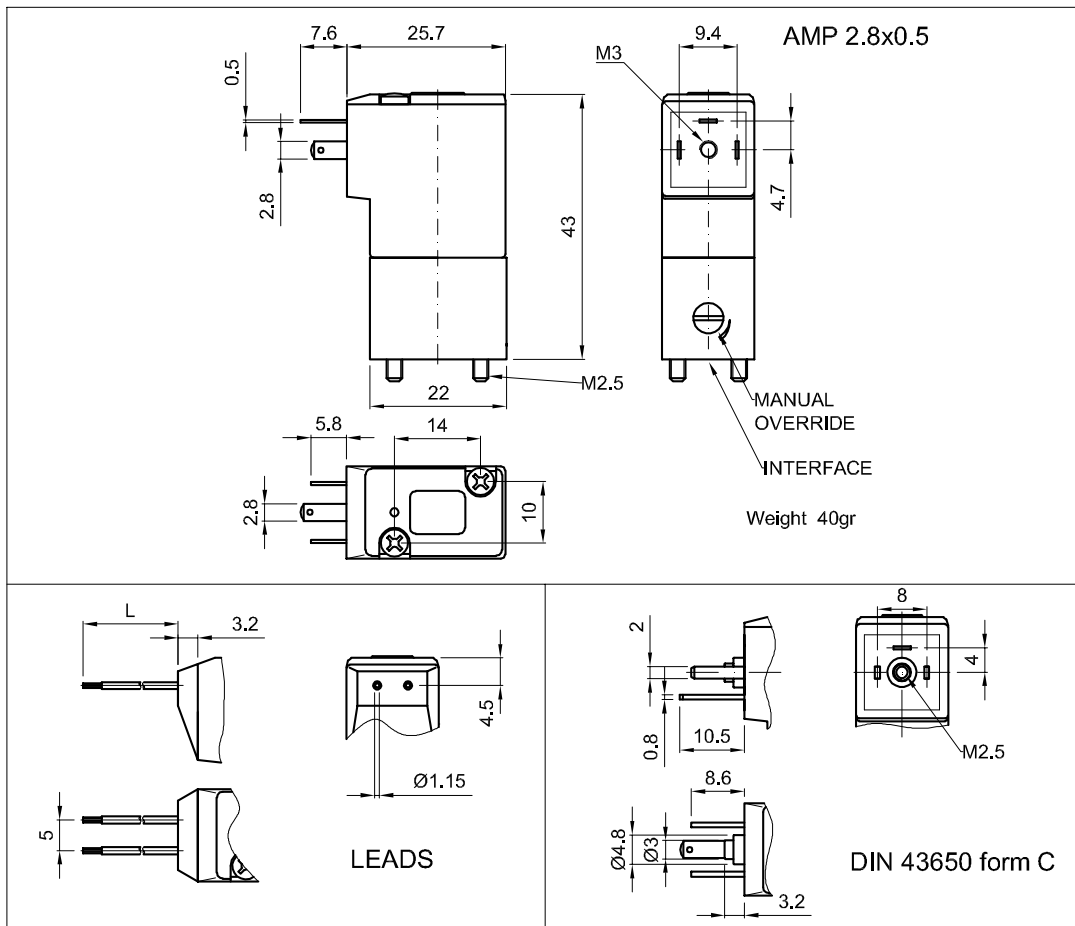

### TYPE NUMBER COMPOSITION

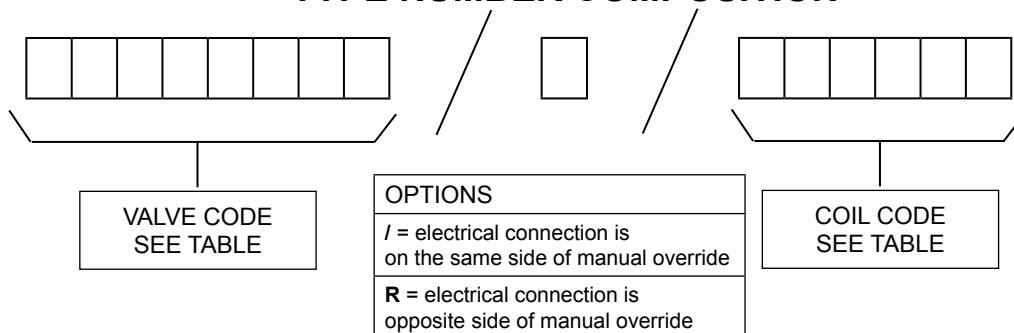

**DESCRIPTION**

Solenoid valve 3 way normally closed  
direct acting poppet type for modular construction

**CONSTRUCTION**

Body	Die-cast aluminium
Armature tube	Brass
Plunger and core	Stainless steel
Springs	Stainless steel
Seal material	NBR FPM EPDM

**3**
**FEATURES**

Media: Air, neutral gases  
Ambient temperature: with class F coil -10°C +55°C  
with class H coil -10°C +80°C  
Universal mounting position

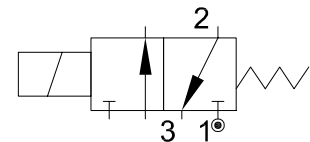

**OPTIONS:** Manual override  
Stainless steel armature tube  
Electroless nickel plating  
Series 7 explosion proof coil according to ATEX - EExmII  
Wet proof coil fixing nut

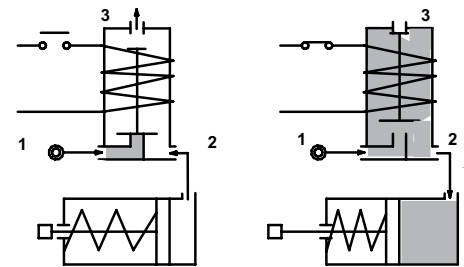

**NOTE: This isn't a standard valve. Please contact the manufacturer for any question.**

CODE ① ②	Connection G ISO 228	Orifice mm		Kv m <sup>3</sup> /h	Differential pressure bar			Nominal power			Coil		Seal ①	Temp. range °C
		Inlet	Exh.		Min	Max		AC Inrush	VA Holding	DC Watt	Series	Width		
						AC	DC							
E350B...15///...	G1/4"	1.5	1.5	0.06	0	10	10	12	8	6.5	3	22	NBR=B	-10 +90
E350B...17///...		1.7	1.7	0.08	0	8	8							
E350B...17///...		1.7	1.7	0.08	0	10	10							
E350M...15///...	M12x1.5	1.5	1.5	0.06	0	10	10	12	8	6.5	3	22	EPDM=E	-10 +140
E350M...17///...		1.7	1.7	0.08	0	8	8							
E350M...17///...		1.7	1.7	0.08	0	10	10							

① Seal      Example: E350MV17///30B FPM seal      M12x1.5 connection  
② Coil      Coil 24V 50/60Hz

COILS	Alternating Current 50/60Hz Volt							Direct Current Volt			Electrical connection	Connectors
	12	24	48	110	220 230	240	380	12	24	48		
Series 3 Width 22 Code ②	30A	30B	30C	30D	30E	30F	30G	300	301	302	DIN 46244	PG9 code 10348000
Series 4 Width 30 Code ②	40A	40B	40C	40D	40E	40F	40G	400	401	402	DIN 43650A	PG9 code 10349000

**DESCRIPTION**  
 Class F insulation  
 Voltage tolerance  
 AC +15% -10%  
 DC ± 10%  
 Protection class  
 IP65 with connector fitted  
 IP00 without connector  
 Continuous service ED100%

**OPTIONS**  
 Class H insulation  
 Cable attached  
 Special coil voltage  
 Special coil powers

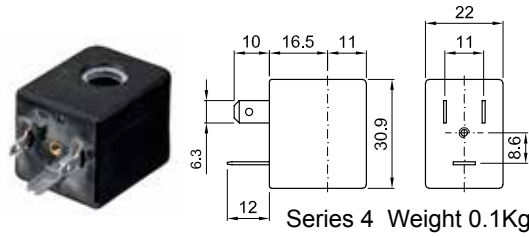
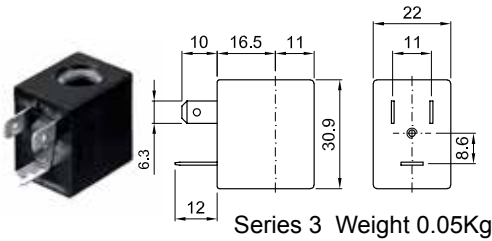

### SPARE PARTS LIST

1. Coil fixing nut
2. Coil
3. Plunger
4. Armature tube with core

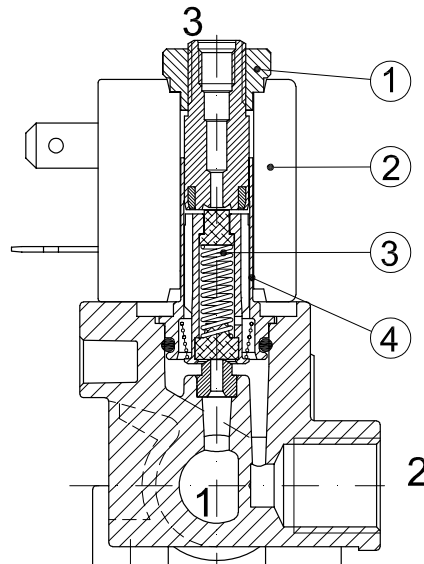

### OVERALL DIMENSION

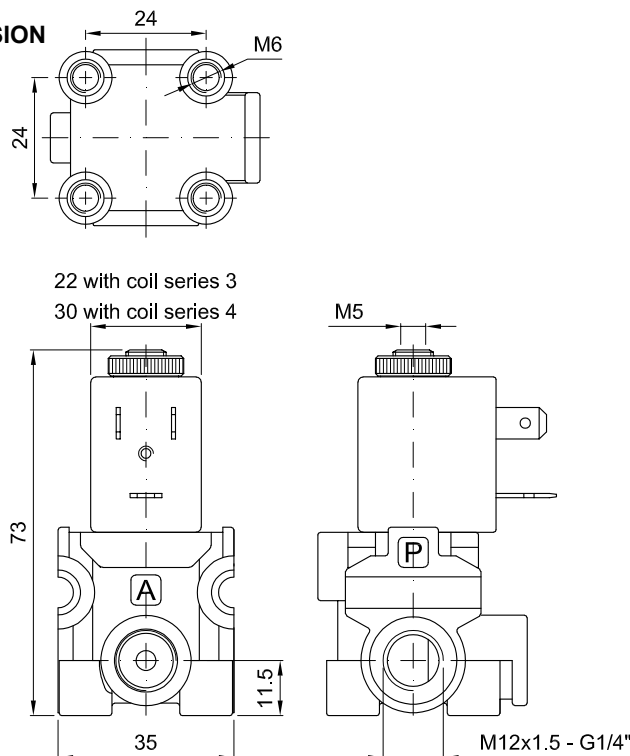

Weight with coil series 3=0.14Kg  
 Weight with coil series 4=0.19Kg

**DESCRIPTION**

Solenoid valve 3 way normally open  
direct acting poppet type for modular construction

**CONSTRUCTION**

Body	Die-cast aluminium
Armature tube	Brass
Plunger and core	Stainless steel
Springs	Stainless steel
Seal material	NBR
	FPM
	EPDM



**3**

**FEATURES**

Media: Air, neutral gases  
Ambient temperature: with class F coil -10°C +55°C  
with class H coil -10°C +80°C

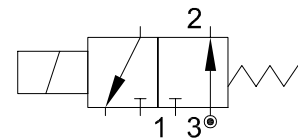

Universal mounting position

**OPTIONS:** Electroless nickel plating  
Series 7 explosion proof coil according to ATEX - EExmII  
Wet proof coil fixing nut

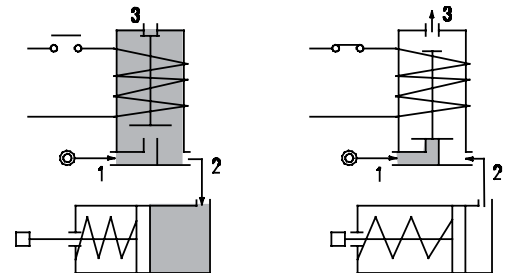

**NOTE:** This isn't a standard valve. Please contact the manufacturer for any question.

CODE ① ②	Connection G ISO 228	Orifice mm		Kv m <sup>3</sup> /h	Differential pressure bar			Nominal power			Coil		Seal ①	Temp. range °C
		Inlet	Exh.		Min	Max AC DC		AC Inrush	VA Holding	DC Watt	Series	Width		
E351B...15///...	G1/4"	1.5	1.5	0.06	0	10	10	12	8	6.5	3	22	NBR=B	-10 +90
E351B...17///...		1.7	1.7	0.08	0	8	8				4	30		
E351B...17///...		1.7	1.7	0.08	0	10	10				3	22		
E351M...15///...	M12x1.5	1.5	1.5	0.06	0	10	10	12	8	6.5	3	22	EPDM=E	-10 +140
E351M...17///...		1.7	1.7	0.08	0	8	8				4	30		
E351M...17///...		1.7	1.7	0.08	0	10	10				3	22		

- ① Seal
- ② Coil

Example: E351MV17///30B FPM seal M12x1.5 connection  
Coil 24V 50/60Hz

COILS	Alternating Current 50/60Hz Volt							Direct Current Volt			Electrical connection	Connectors
	12	24	48	110	220 230	240	380	12	24	48		
Series 3 Width 22 Code ②	30A	30B	30C	30D	30E	30F	30G	300	301	302	DIN 46244	PG9 code 10348000
Series 4 Width 30 Code ②	40A	40B	40C	40D	40E	40F	40G	400	401	402	DIN 43650A	PG9 code 10349000

**DESCRIPTION**  
 Class F insulation  
 Voltage tolerance  
 AC +15% -10%  
 DC ± 10%  
 Protection class  
 IP65 with connector fitted  
 IP00 without connector  
 Continuous service ED100%

**OPTIONS**  
 Class H insulation  
 Cable attached  
 Special coil voltage  
 Special coil powers

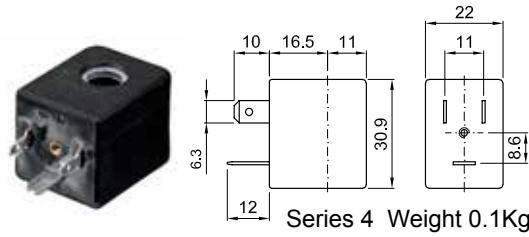
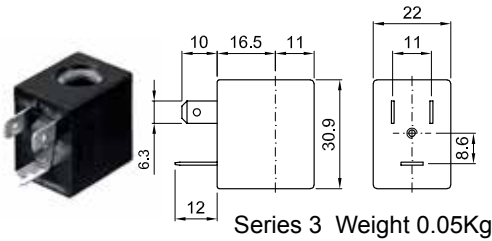

### SPARE PARTS LIST

1. Coil fixing nut
2. Coil
3. Plunger
4. Armature tube with core

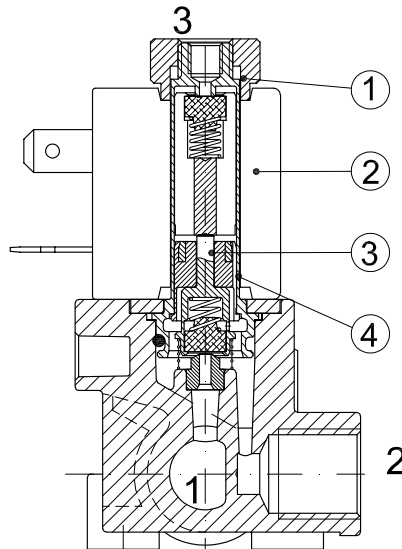

### OVERALL DIMENSION

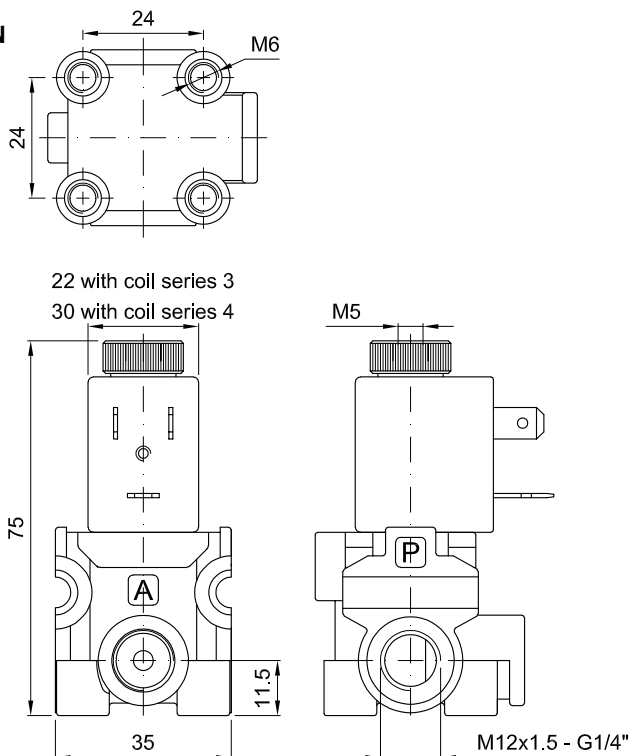

Weight with coil series 3=0.14Kg  
 Weight with coil series 4=0.19Kg



**DESCRIPTION**

Solenoid valve 2 way normally closed with servo-assisted diaphragm

**CONSTRUCTION**

Body and cover	Brass
Armature tube	Stainless steel
Plunger and core	Stainless steel
Springs	Stainless steel
Seal material	NBR - FPM - EPDM



**FEATURES**

- Minimum differential pressure 0.15 bar
- Maximum allowable pressure\* 25 bar
- Maximum fluid viscosity 25cSt (mm<sup>2</sup>/s)
- Ambient temperature: with class F coil -10°C +55°C  
with class H coil -10°C +80°C
- Preferred mounting position with vertical coil above

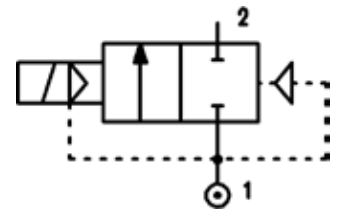

4

- OPTIONS:**
- Manual override
  - Electroless nickel plating
  - Series 7 explosion proof coil according to ATEX - EExmII
  - Version with slow closing diaphragm
  - Version for vacuum applications (air/gas)

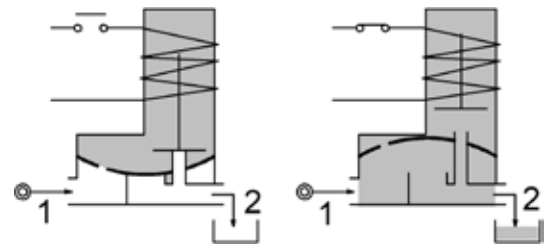

Certified versions:



c us certified coils

CODE ① ②	Connection G ISO 228	Orifice mm	Kv m <sup>3</sup> /h	Differential pressure bar			Nominal power			Coil		Seal ①	Temp. range °C
				Min	Max		AC Inrush	VA Holding	DC Watt	Series	Width		
E107B...10///...	1/4"	10	1.5	0.15	15	15	12	8	6.5	3	22	NBR=B	-10 +90
E107C...10///...	3/8"	10	1.7	0.15	15	15							
E107C...12///...	3/8"	12	2.2	0.15	15	15							
E107D...12///...	1/2"	12	2.5	0.15	15	15						EPDM=E	-10 +140
E107E...18///...	3/4"	18	5.5	0.15	13	13							
E107F...25///...	1"	25	10.2	0.15	10	10							
E107G...30///...	1" 1/4	30	15	0.15	10	10	15	11	5	4	30	FPM=V	-10 +140
③E107C...12/W/...	3/8"	12	2.2	0.5	25	25							
③E107D...12/W/...	1/2"	12	2.5	0.5	25	25							

- ① Seal
- ② Coil
- ③ Reinforced diaphragm

Example: E107DB12///301 NBR seal  
Coil 24V DC

COILS	Alternating Current 50/60Hz Volt							Direct Current Volt			Electrical connection	Connectors
	12	24	48	110	220 230	240	380	12	24	48		
Series 3 Width 22 Code ②	30A	30B	30C	30D	30E	30F	30G	300	301	302	DIN 46244	PG9 code 10348000
Series 4 Width 30 Code ②	40A	40B	40C	40D	40E	40F	40G	400	401	402	DIN 43650A	PG9 code 10349000

**DESCRIPTION**  
 Class F insulation  
 Voltage tolerance  
 AC +15% -10%  
 DC ± 10%  
 Protection class  
 IP65 with connector fitted  
 IP00 without connector  
 Continuous service ED100%

**OPTIONS**  
 Class H insulation  
 Cable attached  
 Special coil voltage  
 Special coil powers  
 CE us certified coils

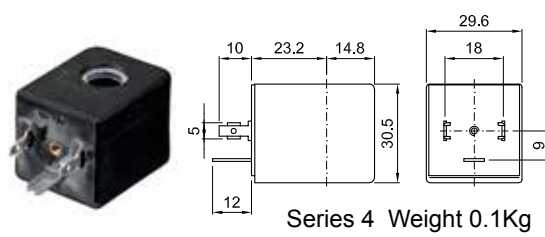
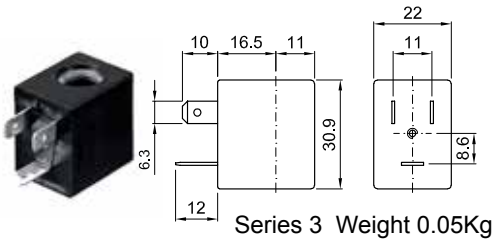

### SPARE PARTS LIST

1. Coil fixing nut
2. Coil
3. Plunger
4. Armature tube with core
5. Diaphragm assembly

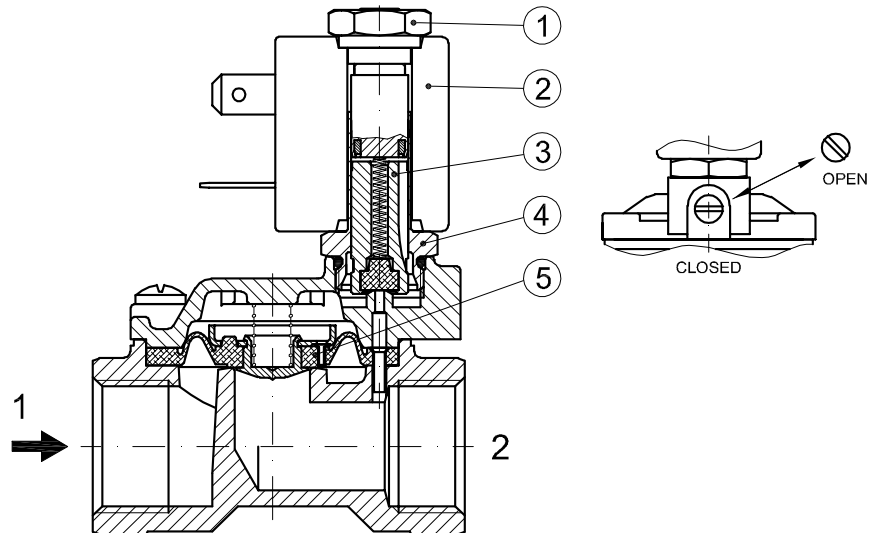

### OVERALL DIMENSION

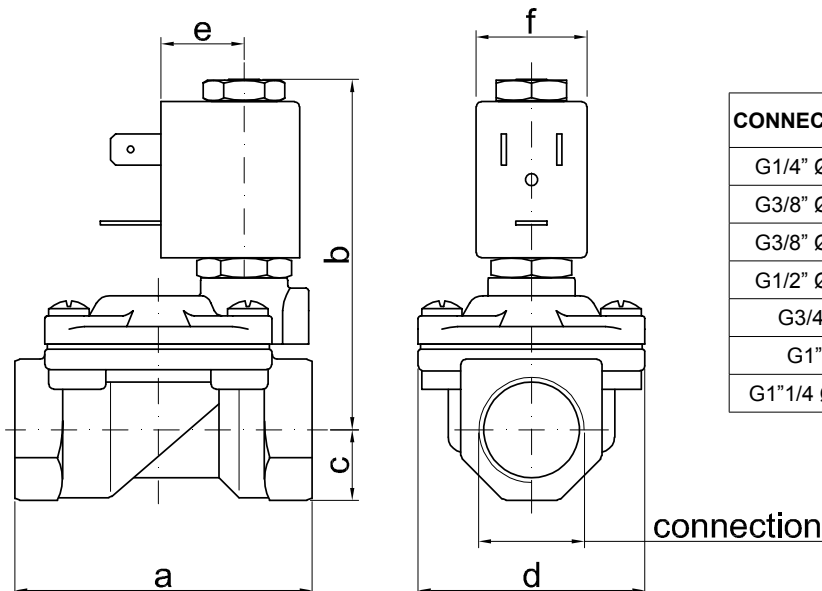

CONNECTION	a	b	c	d	e	f	weight Kg
G1/4" Ø10	49	65	11	32	16	22	0.23
G3/8" Ø10	49	65	11	32	16	22	0.24
G3/8" Ø12	59	70	14	45	16	22	0.42
G1/2" Ø12	59	70	14	45	16	22	0.39
G3/4"	79	76	18	55	16	22	0.65
G1"	96	85	20	72	16	22	1.05
G1 1/4" Ø30	119	92	25	85	16	22	1.70

**DESCRIPTION**

Solenoid valve 2 way normally closed with servo-assisted diaphragm

**CONSTRUCTION**

Body and cover	Brass
Armature tube	Stainless steel
Plunger and core	Stainless steel
Springs	Stainless steel
Seal material	NBR - FPM - EPDM



**FEATURES**

- Minimum differential pressure 0.15÷3 bar
- Maximum allowable pressure\* 20 bar
- Maximum fluid viscosity 25cSt (mm<sup>2</sup>/s)
- Ambient temperature: with class F coil -10°C +55°C  
with class H coil -10°C +80°C
- Preferred mounting position with vertical coil above

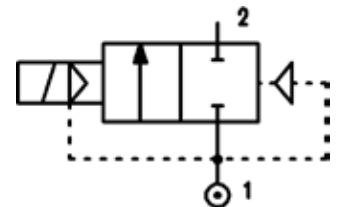

4

- OPTIONS:**
- Manual override
  - Electroless nickel plating
  - Version for vacuum applications (air/gas)
  - us certified coils

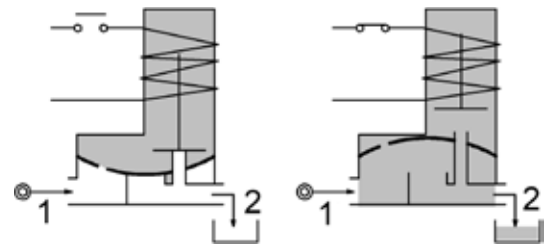

CODE ① ②	Connection G ISO 228	Orifice mm	Kv m <sup>3</sup> /h	Differential pressure bar			Nominal power			Coil		Seal ①	Temp. range °C
				Min	Max		AC Inrush	VA Holding	DC Watt	Series	Width		
					AC	DC							
E107G...37///...	1"1/4	37	18	0.15	10	10	20	15	10	2	30	NBR=B EPDM=E FPM=V	-10 +90 -10 +140 -10 +140
E107H...37///...	1"1/2	37	21	0.15	10	10							
E107I...50///...	2"	50	36	0.15	10	10							
E107MB75///...	2"1/2	75	75	0.3	5	5	20	15	10	2	30	NBR=B	-10 +90
E107RB75///...	3"	75	84	0.3	5	5							
③E107MB75/W/...	2"1/2	75	75	3	15	15							
③E107RB75/W/...	3"	75	84	3	15	15							

- ① Seal
  - ② Coil
  - ③ Reinforced diaphragm
- Example: E107IB50///201 NBR seal  
Coil 24V DC

\* REMARK: The maximum allowable pressure PS for steam 2,5bar (gauge pressure)

COILS	Alternating Current 50/60Hz Volt							Direct Current Volt			Electrical connection	Connectors
	12	24	48	110	220 230	240	380	12	24	48		
Series 2 Width 30 Code ②	20A	20B	20C	20D	20E	20F	20G	200	201	202	DIN 43650A	PG9 code 10349000

**DESCRIPTION**  
 Class F insulation  
 Voltage tolerance  
 AC +15% -10%  
 DC ± 10%  
 Protection class  
 IP65 with connector fitted  
 IP00 without connector  
 Continuous service ED100%

**OPTIONS**  
 Class H insulation  
 Cable attached  
 Special coil voltage  
 Special coil powers  
 CE certified coils

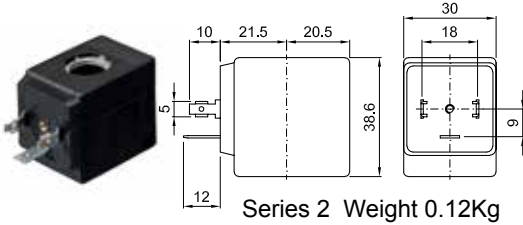

### SPARE PARTS LIST

1. Coil fixing nut
2. Coil
3. Plunger
4. Armature tube with core
5. Diaphragm assembly
6. Speed control valve
7. Water hammering reducer  
 $\varnothing 0.8-\varnothing 1-\varnothing 1.2$

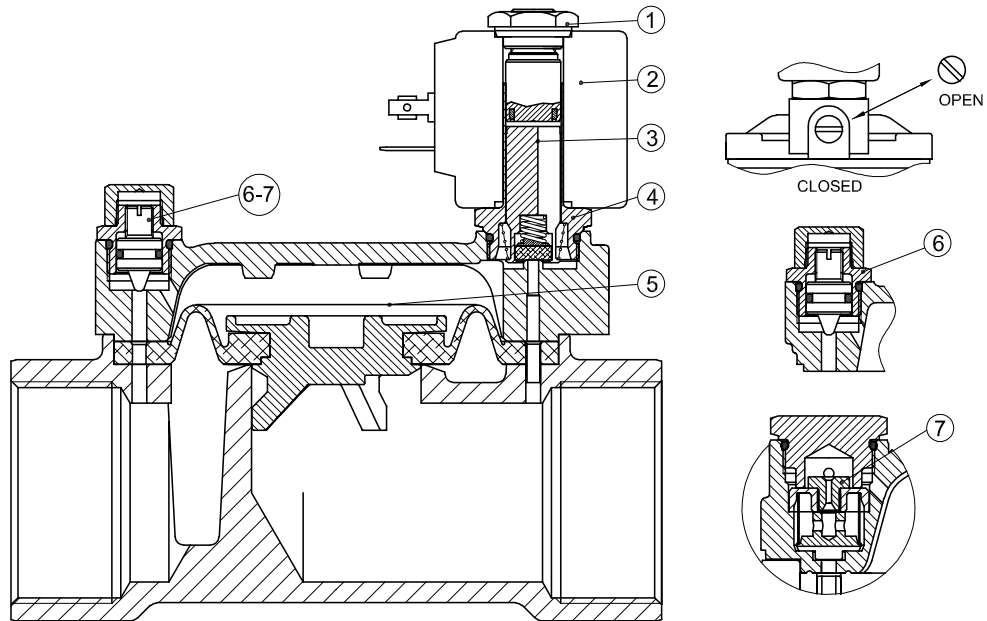

### OVERALL DIMENSION

CONNECTION	a	b	c	d	e	f	weight Kg
G1"1/4	142	105	28	102	21	30	3.00
G1"1/2	142	105	28	102	21	30	2.85
G2"	158	115	35	119	21	30	4.30
G2"1/2	226	134	51	169	21	30	11.7
G3"	226	134	51	169	21	30	9.9

**DESCRIPTION**

Solenoid valve 2 way normally closed with servo-assisted diaphragm.

With explosion proof coil certified for hazardous area:

⊕ Ex II 2GD Ex d IIC T6 or T5 or T4 Gb  
 Ex tb IIC T80°C or T95°C or T130°C Db IP66  
 Tamb -10°C ÷ +35°C(T6) or +50°C(T5) or +60°C(T4)

(other certifications e.g. Gost-r, Baseefa, CCOE etc. on request)



**VALVE CONSTRUCTION**

Body Brass  
 Seal material FPM, NBR

**EXPLOSION PROOF COIL CONSTRUCTION**

Housing Red colour alloy  
 Electrical connection 1/2" NPT

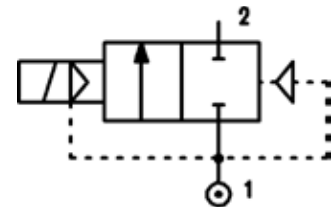

**4**

**FEATURES**

Minimum differential pressure 0.15bar  
 Maximum allowable pressure 25bar  
 Maximum fluid viscosity 25cSt (mm<sup>2</sup>/s)  
 Ambient temperature: -10°C ÷ +35°C(T6), +50°C(T5), +60°C  
 Mounting position with vertical coil above

**OPTIONS:** Electroless nickel-plating  
 Versions with slow closing diaphragm

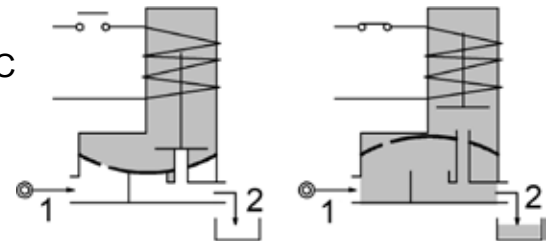

**NOTE:** The solenoid valve is suitable only with media that are **NOT** potentially explosive

CODE ②	Connection G ISO 228	Orifice mm	Kv m <sup>3</sup> /h	Differential pressure bar			Nominal power		Coil Series	Seal	Temp. range °C
				Min	Max AC DC		AC Holding	DC			
A107BV10/1/...	1/4"	10	1.5	0.15	15	15	12 VA	8W	A6	FPM=V	-10 +140
A107CV10/1/...	3/8"	10	1.7	0.15	15	15					
A107CV12/1/...	3/8"	12	2.2	0.15	15	15					
A107DV12/1/...	1/2"	12	2.5	0.15	15	15					
A107EV18/1/...	3/4"	18	5.5	0.15	13	13					
A107FV25/1/...	1"	25	10.2	0.15	10	10					
A107GV30/1/...	1"1/4	30	15	0.15	10	10					
A107GV37/1/...	1"1/4	37	18	0.15	10	10					
A107HV37/1/...	1"1/2	37	21	0.15	10	10					
A107IV50/1/...	2"	50	36	0.15	10	10					
A107MB75/1/...	2"1/2	75	75	0.3	5	5					
A107RB75/1/...	3"	75	84	0.3	5	5	NBR=B	-10 +90			

② Coil

COILS	Alternating Current 50/60Hz Volt				Direct Current Volt			Electrical connection
	24	48	110	220 230	12	24	48	
Series A6 Code ②	A6B	A6C	A6D	A6E	A60	A61	A62	1/2" NPT

**DESCRIPTION**  
 Voltage tolerance  
 AC +15% -10%  
 DC ± 10%  
 Protection class IP66  
 Continuous service ED100%

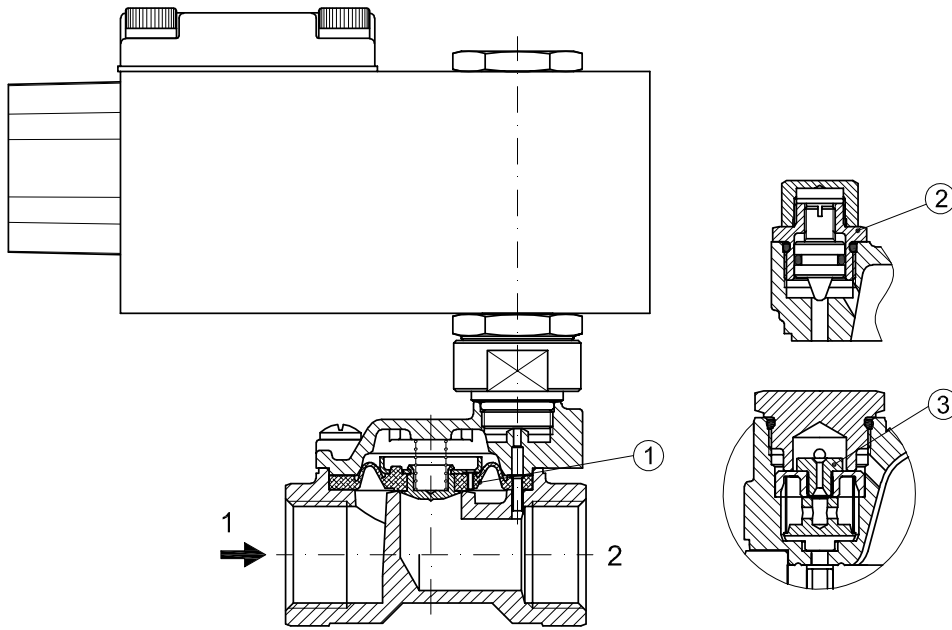

### OVERALL DIMENSION

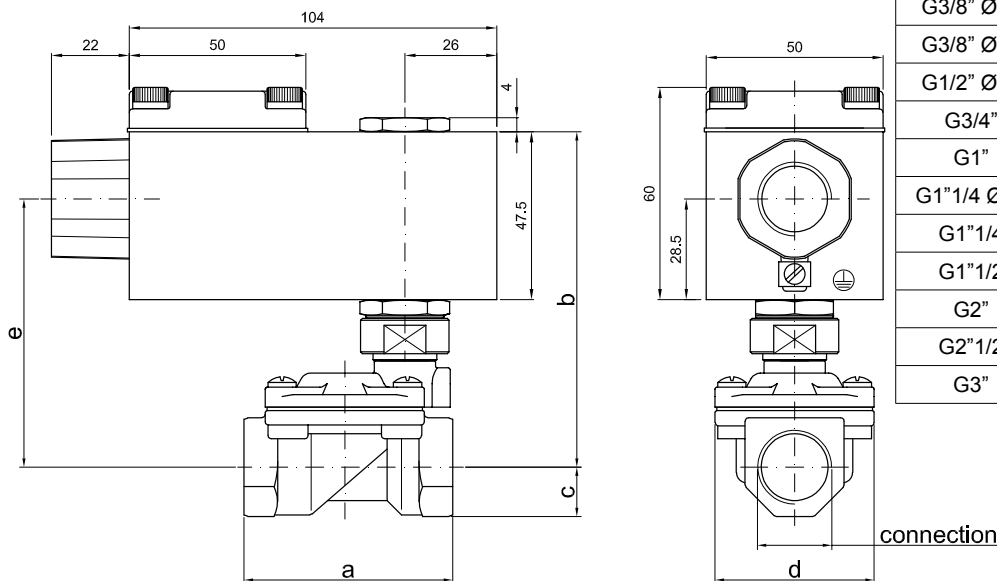

CONNECTION	a	b	c	d	e	weight Kg
G1/4" Ø10	49	90	11	32	71	0.72
G3/8" Ø10	49	90	11	32	71	0.72
G3/8" Ø12	59	95	14	45	76	0.92
G1/2" Ø12	59	95	14	45	76	0.92
G3/4"	79	101	18	54	82	1.10
G1"	96	110	20	72	91	1.50
G1"1/4 Ø30	119	118	25	85	99	2.27
G1"1/4	142	110	28	102	91	3.33
G1"1/2	142	110	28	102	91	3.12
G2"	158	119	35	119	100	4.72
G2"1/2	226	138	51	169	119	10.4
G3"	226	138	51	169	119	10

**DESCRIPTION**

Solenoid valve 2 way normally closed with assisted-lift diaphragm

**CONSTRUCTION**

Body and cover	Brass
Armature tube	Stainless steel
Plunger and core	Stainless steel
Springs	Stainless steel
Seal material	FPM



**FEATURES**

Maximum allowable pressure 25 bar  
 Maximum fluid viscosity 25cSt (mm<sup>2</sup>/s)  
 Ambient temperature: with class F coil -10°C +55°C  
 with class H coil -10°C +80°C

Preferred mounting position with vertical coil above  
 For complete diaphragm opening, a differential pressure of at least 0,15 bar is necessary

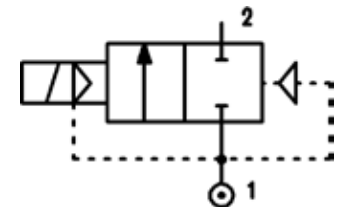

**4**

**OPTIONS:** Electroless nickel plating  
 c us certified coils

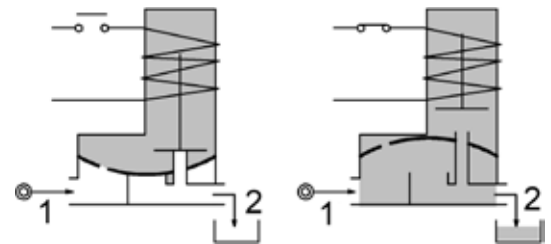

CODE ②	Connection G ISO 228	Orifice mm	Kv m <sup>3</sup> /h	Differential pressure bar			Nominal power			Coil		Seal	Temp. range °C
				Min	Max		AC Inrush	VA Holding	DC Watt	Series	Width		
					AC	DC							
E108CV12///...	3/8"	12	2	0	10	-	20	15	-	2	30	FPM=V	-10 +140
E108DV12///...	1/2"	12	2.2	0	10	-							
E108CV12///...	3/8"	12	2	0	12	10	40	30	27	5	36		
E108DV12///...	1/2"	12	2.2	0	12	10							
E108EV18///...	3/4"	18	4.5	0	9	-	40	30	-				
E108FV25///...	1"	25	8.5	0	7	-							
D108EV18///...	3/4"	18	4.5	0	-	9	-	-	27				
D108FV25///...	1"	25	8.5	0	-	8							

② Coil Example: E108FV25///52B FPM seal  
 Coil 24V 50/60Hz

COILS	Alternating Current 50/60Hz Volt							Direct Current Volt			Electrical connection	Connectors
	12	24	48	110	220 230	240	380	12	24	48		
Series 2 Width 30 Code ②	20A	20B	20C	20D	20E	20F	20G	200	201	202	DIN 43650A	PG9 code 10349000
Series 5 Width 36 Code ②	52A	52B	52C	52D	52E	52F	52G	520	521	522	DIN 43650A	PG11 code 10349001

**DESCRIPTION**  
 Insulation class  
 Series 2 =F Series 5=H  
 Voltage tolerance  
 AC +15% -10%  
 DC ± 10%  
 Protection class  
 IP65 with connector fitted  
 IP00 without connector  
 Continuous service ED100%

**OPTIONS**  
 Class H insulation (series 2)  
 Cable attached  
 Special coil voltage  
 Special coil powers  
 US certified coils

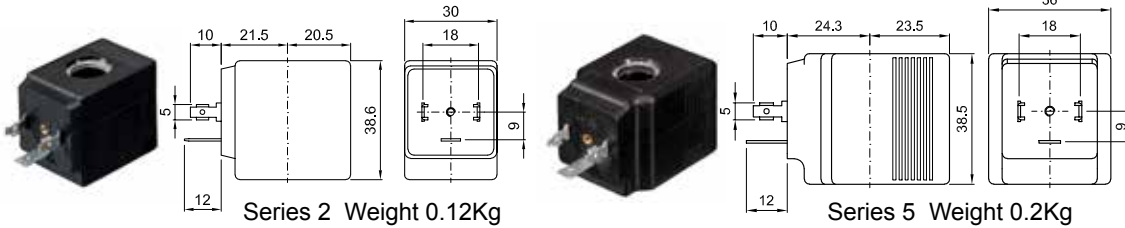

### SPARE PARTS LIST

1. Coil fixing nut
2. Coil
3. Plunger
4. Armature tube with core

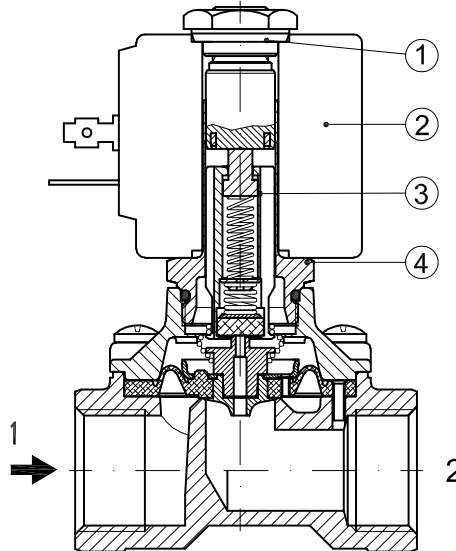

### OVERALL DIMENSION

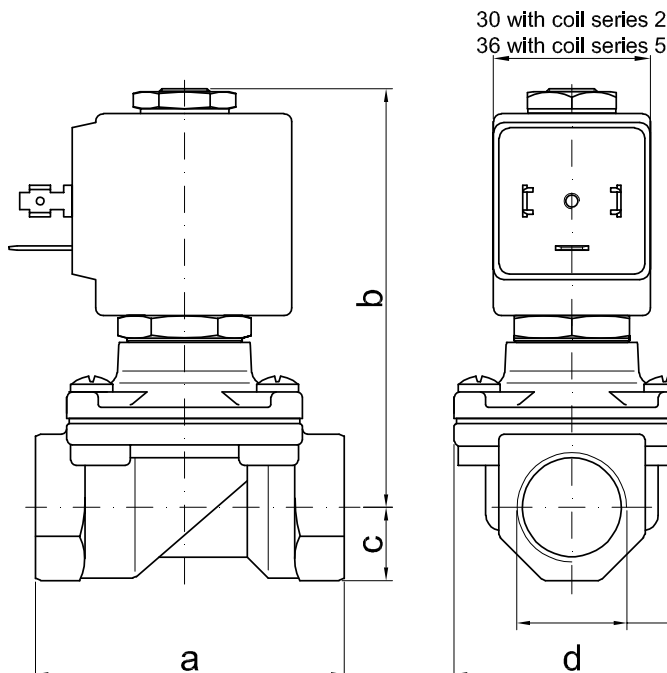

CONNECTION	a	b	c	d	weight Kg	
					series 2	series 5
G3/8"	59	83	14	45	0.52	0.60
G1/2"	59	83	14	45	0.49	0.57
G3/4"	79	90	18	55	-	0.81
G1"	96	101	20	72	-	1.22

connection



**DESCRIPTION**

Solenoid valve 2 way with servo-assisted diaphragm bi-stable.

The bi-stable function is achieved by the use of a polarised permanent magnet energising the coil with a DC current for at least 15ms in the reverse direction of the previous impulse.



**CONSTRUCTION**

Body and cover	Brass
Armature tube	Stainless steel
Plunger and core	Stainless steel
Magnet	NeFeB
Springs	Stainless steel
Seal material	NBR - FPM - EPDM

**FEATURES**

- Minimum differential pressure 0.15 bar
- Maximum allowable pressure\* 25 bar
- Maximum fluid viscosity 25cSt (mm<sup>2</sup>/s)
- Ambient temperature: with class F coil -10°C +55°C  
with class H coil -10°C +80°C
- Preferred mounting position with vertical coil above

**OPTIONS:** Special coil powers

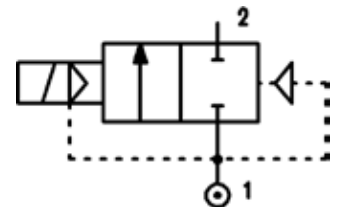

**4**

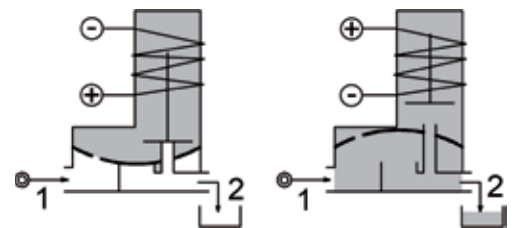

CODE ① ②	Connection G ISO 228	Orifice mm	Kv m <sup>3</sup> /h	Differential pressure bar		Nominal power DC Watt	Coil		Seal ①	Temp. range °C
				Min	Max		Series	Width		
D117B...10///...	1/4"	10	1.5	0.15	8	2	3	22	NBR=B	-10 +90
					15	5				
D117C...10///...	3/8"	10	1.7	0.15	8	2				
					15	5				
D117C...12///...	3/8"	12	2.2	0.15	8	2				
					15	5				
D117D...12///...	1/2"	12	2.5	0.15	8	2				
					15	5				
D117E...18///...	3/4"	18	5.5	0.15	8	2				
					13	5				
D117F...25///...	1"	25	10.2	0.15	8	2				
					10	5				
D117G...30///...	1"1/4	30	15	0.15	8	2				
					10	5				
									FPM=V	-10 +140

① Seal  
② Coil

Example: D117DB12///301120 NBR seal  
Coil 24V DC 2W

COILS	Direct Current															Electrical connection	Connectors
	3V			6V			9V			12V			24V				
	2W	5W	6.5W	2W	5W	6.5W	2W	5W	6.5W	2W	5W	6.5W	2W	5W	6.5W		
Series 3 Width 22 Code ②	308120			305120	305150		307120	307150		300120	300150	300	301120	301150	301	DIN 46244	PG9 code 10348000

**DESCRIPTION**  
 Class F insulation  
 Voltage tolerance  $\pm 10\%$   
 Protection class  
 IP65 with connector fitted  
 IP00 without connector  
 Continuous service ED100%

**OPTIONS**  
 Class H insulation  
 Cable attached  
 Special coil voltage  
 Special coil powers

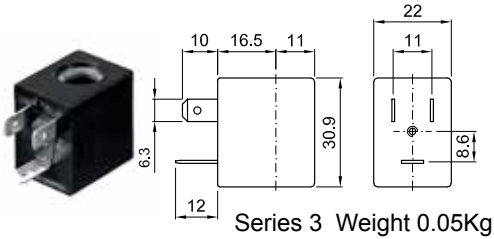

### SPARE PARTS LIST

1. Coil fixing nut
2. Coil
3. Plunger
4. Armature tube with core
5. Diaphragm assembly

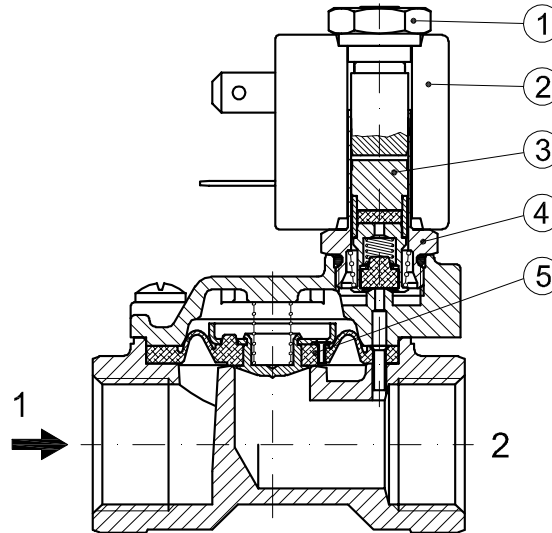

### OVERALL DIMENSION

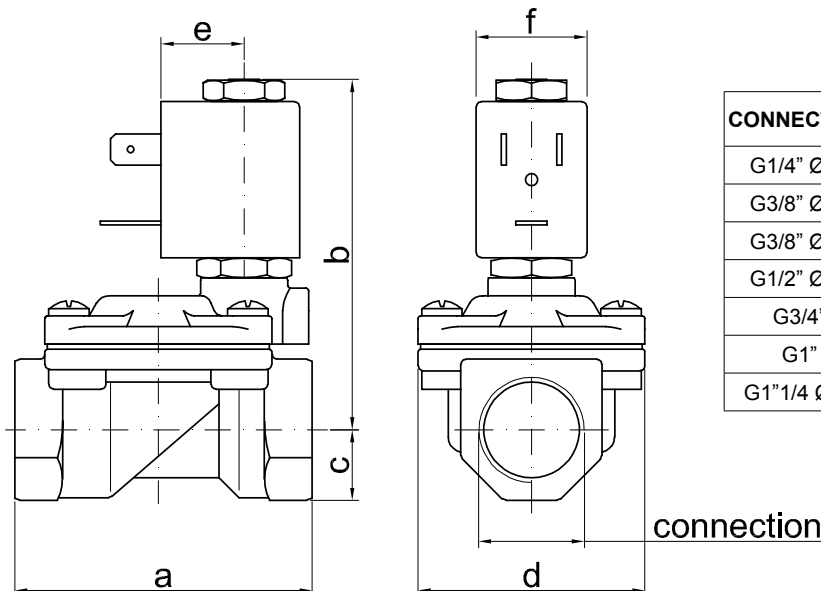

CONNECTION	a	b	c	d	e	f	weight Kg
G1/4" Ø10	49	65	11	32	16	22	0.23
G3/8" Ø10	49	65	11	32	16	22	0.24
G3/8" Ø12	59	70	14	45	16	22	0.42
G1/2" Ø12	59	70	14	45	16	22	0.39
G3/4"	79	76	18	55	16	22	0.65
G1"	96	85	20	72	16	22	1.05
G1 1/4" Ø30	119	92	25	85	16	22	1.70

### DESCRIPTION

Solenoid valve 2 way with servo-assisted diaphragm bi-stable.  
 The bi-stable function is achieved by the use of a polarised permanent magnet energising the coil with a DC current for at least 15ms in the reverse direction of the preceding impulse.



### CONSTRUCTION

Body and cover	Brass
Armature tube	Stainless steel
Plunger and core	Stainless steel
Magnet	NeFeB
Springs	Stainless steel
Seal material	NBR - FPM - EPDM

### FEATURES

- Minimum differential pressure 0.15÷3 bar
- Maximum allowable pressure\* 20 bar
- Maximum fluid viscosity 25cSt (mm<sup>2</sup>/s)
- Ambient temperature: with class F coil -10°C +55°C  
with class H coil -10°C +80°C
- Preferred mounting position with vertical coil above

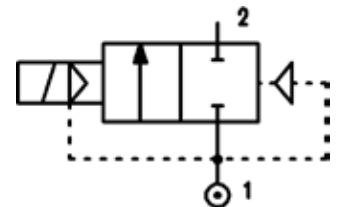

4

**OPTIONS:** Special coil powers

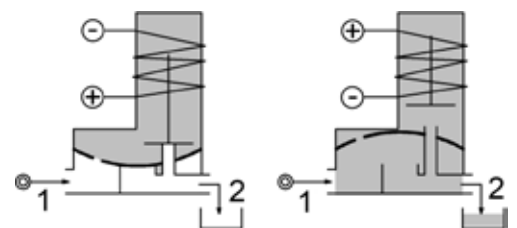

CODE ① ②	Connection G ISO 228	Orifice mm	Kv m <sup>3</sup> /h	Differential pressure bar		Nominal power DC Watt	Coil		Seal ①	Temp. range °C		
				Min	Max		Series	Width				
D117G...37//... D117H...37//... D117I...50//... D117MB75//... D117RB75//... ③D117RB75/W/... ③D117MB75/W/...	1"1/4 1"1/2 3/8" 1/2" 3/4" 1" 1"1/4	37 37 50 75 75 75 75	18 21 36 75 84 75 84	0.15 0.15 0.15 0.3 0.3 3 3	10 10 10 5 5 10 10	10	2	30	NBR=B	-10 +90		
											EPDM=E	-10 +140
											FPM=V	-10 +140

- ① Seal Example: D117IB50//201 NBR seal
- ② Coil Coil 24V DC
- ③ Reinforced diaphragm

\* REMARK: The maximum allowable pressure PS for steam 2,5bar (gauge pressure)

COILS	Direct Current Volt			Electrical connection	Connectors
	12	24	48		
Series 2 Width 30 Code ②	200	201	202	DIN 43650A	PG9 code 10349000

**DESCRIPTION**  
 Class F insulation  
 Voltage tolerance  
 AC +15% -10%  
 DC ± 10%  
 Protection class  
 IP65 with connector fitted  
 IP00 without connector  
 Continuous service ED100%

**OPTIONS**  
 Class H insulation  
 Cable attached  
 Special coil voltage  
 Special coil powers

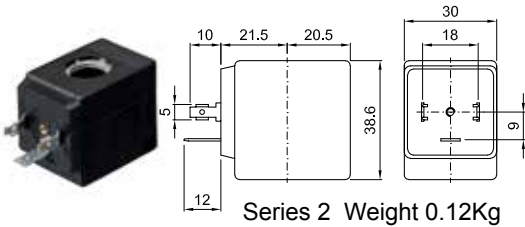

### SPARE PARTS LIST

1. Coil fixing nut
2. Coil
3. Plunger
4. Armature tube with core
5. Diaphragm assembly
6. Speed control valve
7. Water hammering reducer  
 $\varnothing 0.8\text{-}\varnothing 1\text{-}\varnothing 1.2$

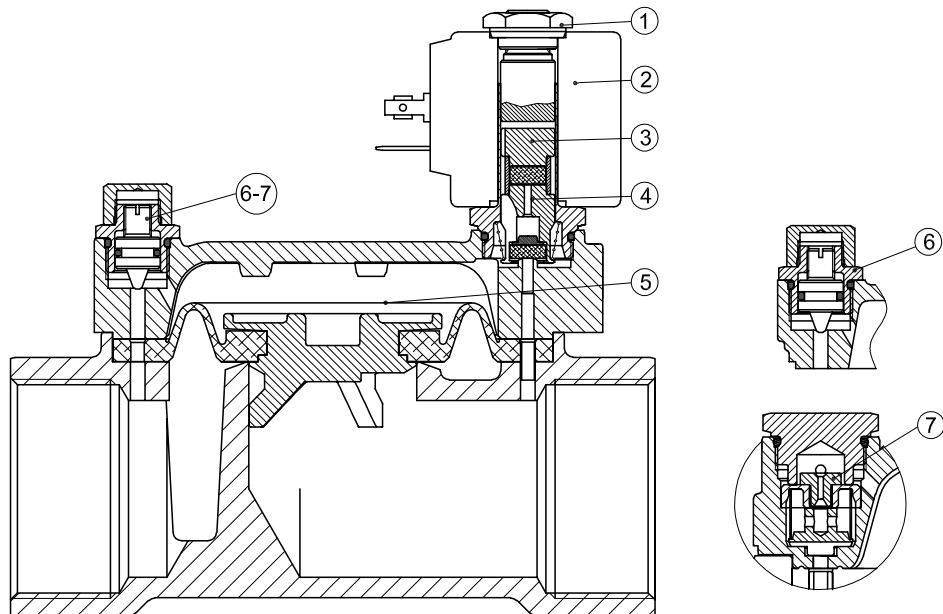

### OVERALL DIMENSION

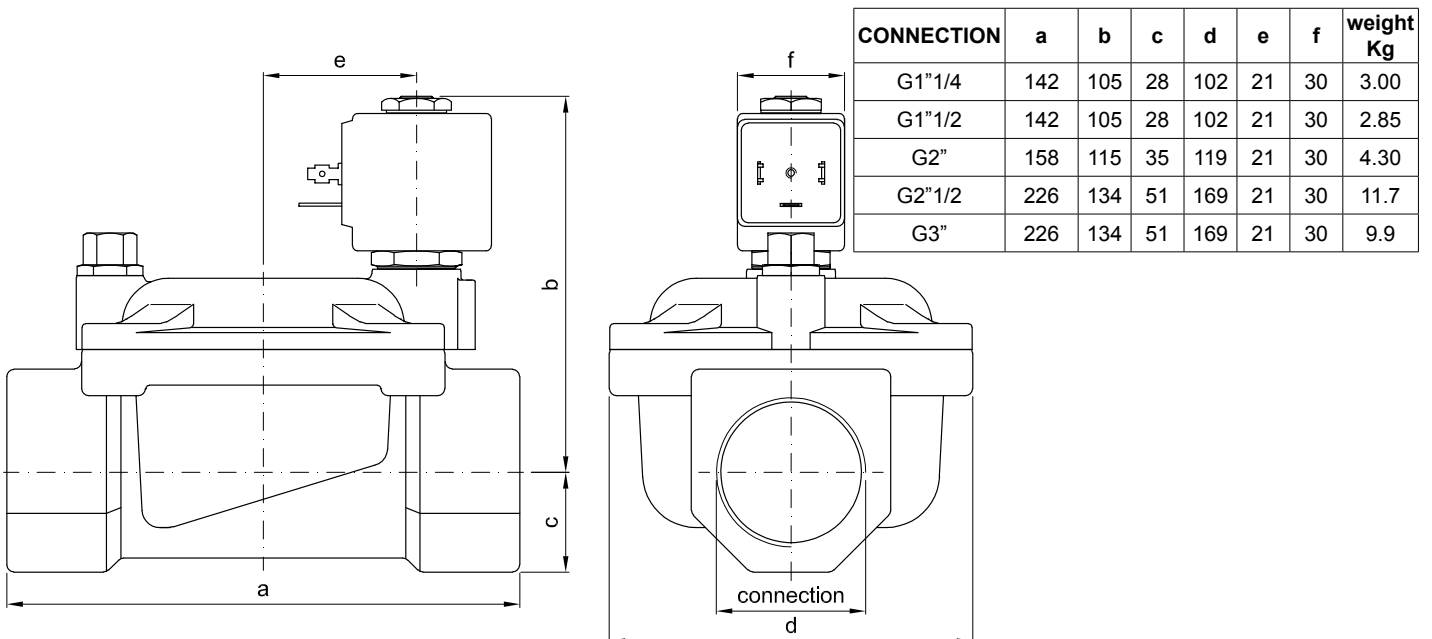

**DESCRIPTION**

Solenoid valve 2 way normally closed with servo-assisted piston

**CONSTRUCTION**

Body and cover	Brass
Armature tube	Stainless steel
Plunger and core	Stainless steel
Springs	Stainless steel
Piston	Brass
Piston seal	PTFE reinforced
Seal material	Main seal PTFE, other FPM



**FEATURES**

- Minimum differential pressure 1 bar
- Maximum allowable pressure 60 bar
- Maximum fluid viscosity 25cSt (mm<sup>2</sup>/s)
- Ambient temperature: with class F coil -10°C +55°C  
with class H coil -10°C +80°C
- Preferred mounting position with vertical coil above

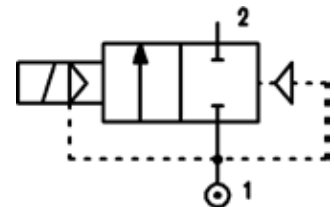

**4**

**OPTIONS:** Electroless nickel plating  
c us certified coils

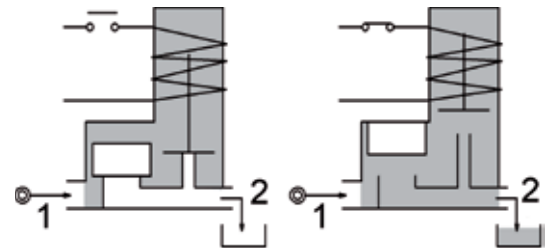

CODE ①	Connection G ISO 228	Orifice mm	Kv m <sup>3</sup> /h	Differential pressure bar			Nominal power			Coil		Seal	Temp. range °C
				Min	Max		AC Inrush	VA Holding	DC Watt	Series	Width		
					AC	DC							
E119BV52///...	1/4"	5.2	0.47	1.5	50	50	20	15	10	2	30	PTFE/ FPM	-10 +140
E119CV12///...	3/8"	12	2	1	30	30							
E119DV12///...	1/2"	12	2.2	1	30	30							
②E119CV12/1/...	3/8"	12	2	1	50	50	40	30	27	5	36		
②E119DV12/1/...	1/2"	12	2.2	1	50	50							

- ① Seal
- ② Maximum allowable pressure 60 bar

Example: E119DV12/1/521 FPM seal  
Coil 24V DC  
Maximum differential pressure 50bar

COILS	Alternating Current 50/60Hz Volt							Direct Current Volt			Electrical connection	Connectors
	12	24	48	110	220 230	240	380	12	24	48		
Series 2 Width 30 Code ②	20A	20B	20C	20D	20E	20F	20G	200	201	202	DIN 43650A	PG9 code 10349000
Series 5 Width 36 Code ②	52A	52B	52C	52D	52E	52F	52G	520	521	522	DIN 43650A	PG11 code 10349001

**DESCRIPTION**  
 Insulation class  
 Series 2 =F Series 5=H  
 Voltage tolerance  
 AC +15% -10%  
 DC ± 10%  
 Protection class  
 IP65 with connector fitted  
 IP00 without connector  
 Continuous service ED100%

**OPTIONS**  
 Class H insulation (series 2)  
 Cable attached  
 Special coil voltage  
 Special coil powers  
 e us certified coils

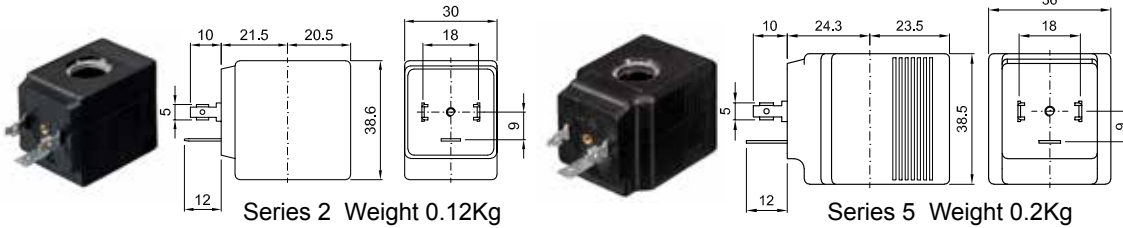

### SPARE PARTS LIST

1. Coil fixing nut
2. Coil
3. Plunger
4. Armature tube with core
5. Piston assembly

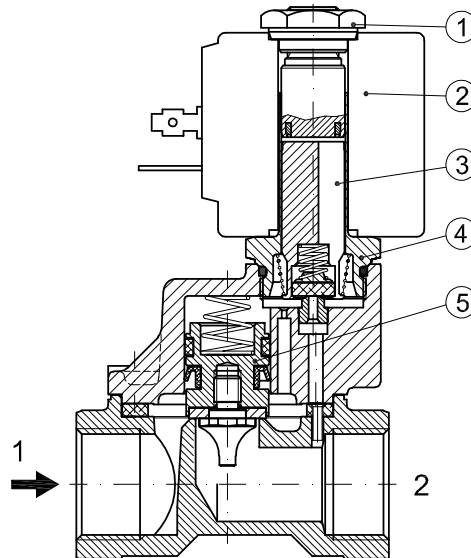

### OVERALL DIMENSION

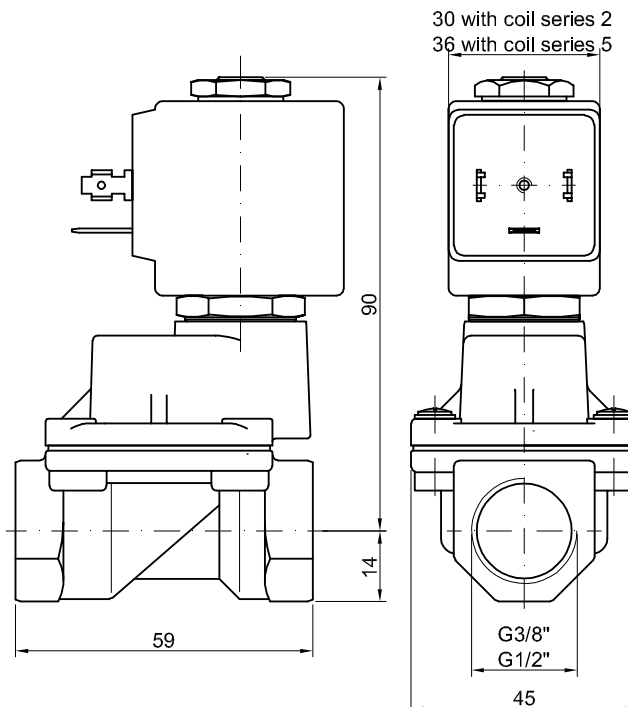

Weight with coil series 2=0.63Kg  
 Weight with coil series 5=0.71Kg

**DESCRIPTION**

Solenoid valve 2 way normally closed with servo-assisted piston for use with steam

**CONSTRUCTION**

Body and cover	Brass
Armature tube	Stainless steel
Plunger and core	Stainless steel
Springs	Stainless steel
Piston	Stainless steel
Piston seal	PTFE reinforced
Seal material	PTFE



**FEATURES**

Minimum differential pressure 2,5 bar  
 Ambient temperature with class H coil only: -10°C +80°C  
 Preferred mounting position with vertical coil above

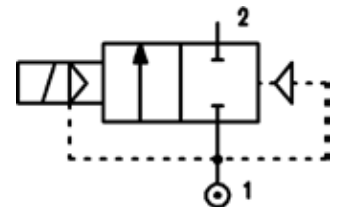

**4**

**OPTIONS:** Electroless nickel plating  
 c us certified coils

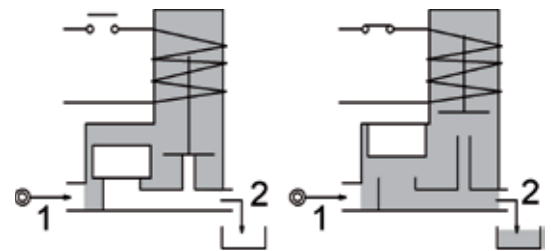

CODE ①	Connection G ISO 228	Orifice mm	Kv m <sup>3</sup> /h	Differential pressure bar			Nominal power			Coil		Seal	Temp. range °C
				Min	Max		AC Inrush	VA Holding	DC Watt	Series	Width		
					AC	DC							
E119CW12/1/...	3/8"	12	2	2.5	9	9	20	15	10	2	30	PTFE/ FPM	-10 +180
E119DW12/1/...	1/2"	12	2.2	2.5	9	9							

① Seal  
 Maximum allowable leakage <0.2NI/h

Example: E119DW12/1/221 FPM seal  
 Coil 24V DC

COILS	Alternating Current 50/60Hz Volt							Direct Current Volt			Electrical connection	Connectors
	12	24	48	110	220 230	240	380	12	24	48		
Series 2 Width 30 Code ②	22A	22B	22C	22D	22E	22F	22G	220	221	222	DIN 43650A	PG9 code 10349000

**DESCRIPTION**  
 Insulation class H  
 Voltage tolerance  
 AC +15% -10%  
 DC ± 10%  
 Protection class  
 IP65 with connector fitted  
 IP00 without connector  
 Continuous service ED100%

**OPTIONS**  
 Cable attached  
 Special coil voltage  
 Special coil powers  
 US certified coils

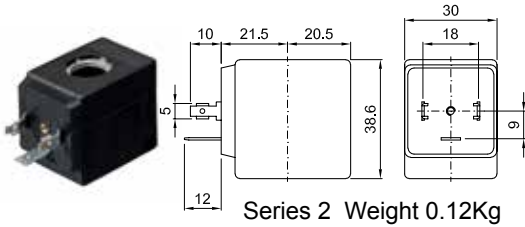

### SPARE PARTS LIST

1. Coil fixing nut
2. Coil
3. Plunger
4. Armature tube with core
5. Piston assembly

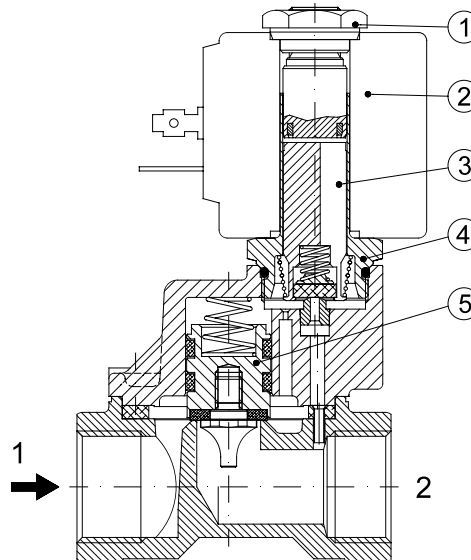

### OVERALL DIMENSION

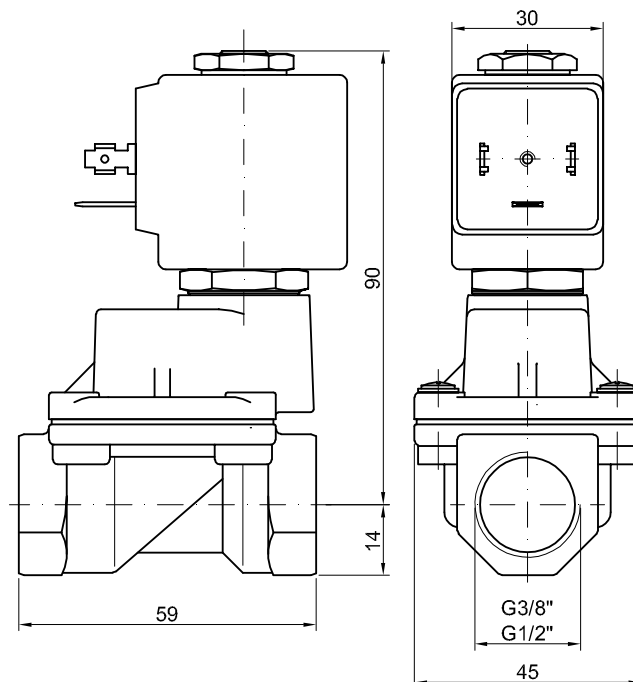

Weight=0.63Kg



**DESCRIPTION**

Solenoid valve 2 way normally closed in stainless steel AISI 316 with servo-assisted diaphragm

**CONSTRUCTION**

Body and cover	Stainless steel
Armature tube	Stainless steel
Plunger and core	Stainless steel
Springs	Stainless steel
Seal material	NBR - FPM - EPDM



**FEATURES**

- Minimum differential pressure 0.15 bar
- Maximum allowable pressure\* 25 bar
- Maximum fluid viscosity 25cSt (mm<sup>2</sup>/s)
- Ambient temperature: with class F coil -10°C +55°C  
with class H coil -10°C +80°C
- Preferred mounting position with vertical coil above

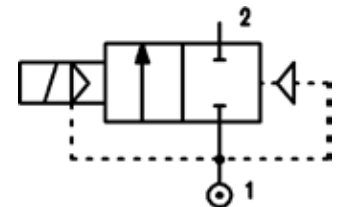

4

- OPTIONS:**
- Manual override
  - Series 7 explosion proof coil according to ATEX - EExmII
  - Food approval seal material
  - Version with slow closing diaphragm
  - Version for use with oxygen
  - Silver shading ring
  - c us certified coils

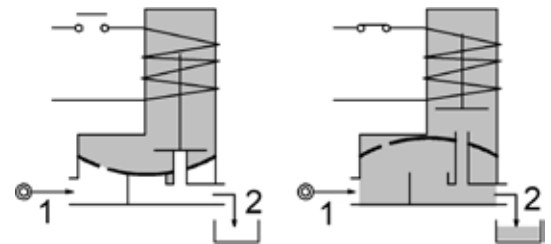

CODE ① ②	Connection G ISO 228	Orifice mm	Kv m <sup>3</sup> /h	Differential pressure bar			Nominal power			Coil		Seal ①	Temp. range °C
				Min	Max		AC Inrush	VA Holding	DC Watt	Series	Width		
					AC	DC							
E177C...12///...	3/8"	12	2.2	0.15	15	15	12	8	6.5	3	22	NBR=B	-10 +90
E177D...12///...	1/2"	12	2.5	0.15	15	15						EPDM=E	-10 +140
E177E...18///...	3/4"	18	5.5	0.15	13	13						FPM=V	-10 +140
E177F...25///...	1"	25	10.2	0.15	10	10							

① Seal Example: E177DB12///301 NBR seal  
 ② Coil Coil 24V DC

COILS	Alternating Current 50/60Hz Volt							Direct Current Volt			Electrical connection	Connectors
	12	24	48	110	220 230	240	380	12	24	48		
Series 3 Width 22 Code ②	30A	30B	30C	30D	30E	30F	30G	300	301	302	DIN 46244	PG9 code 10348000

**DESCRIPTION**  
 Class F insulation  
 Voltage tolerance  
 AC +15% -10%  
 DC ± 10%  
 Protection class  
 IP65 with connector fitted  
 IP00 without connector  
 Continuous service ED100%

**OPTIONS**  
 Class H insulation  
 Cable attached  
 Special coil voltage  
 Special coil powers  
 cULus certified coils

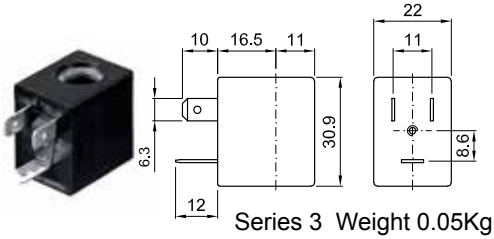

### SPARE PARTS LIST

1. Coil fixing nut
2. Coil
3. Plunger
4. Armature tube with core
5. Diaphragm assembly

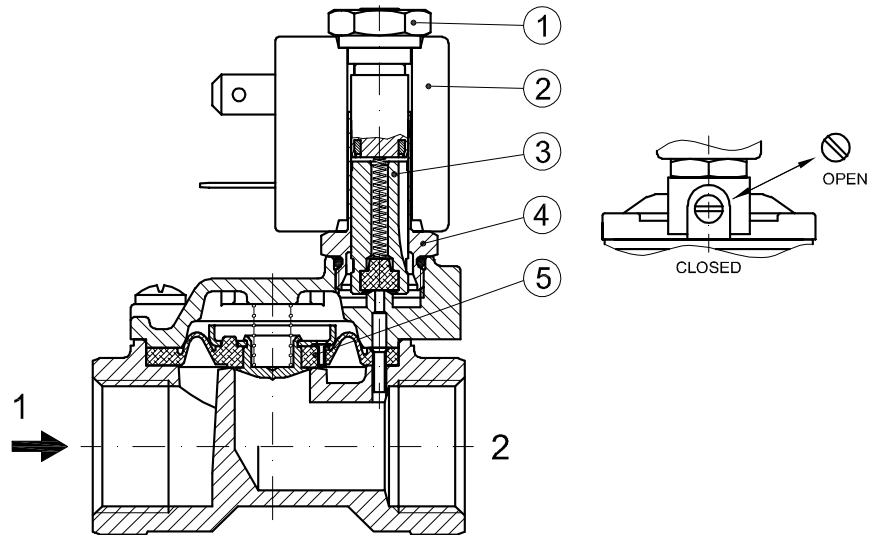

### OVERALL DIMENSION

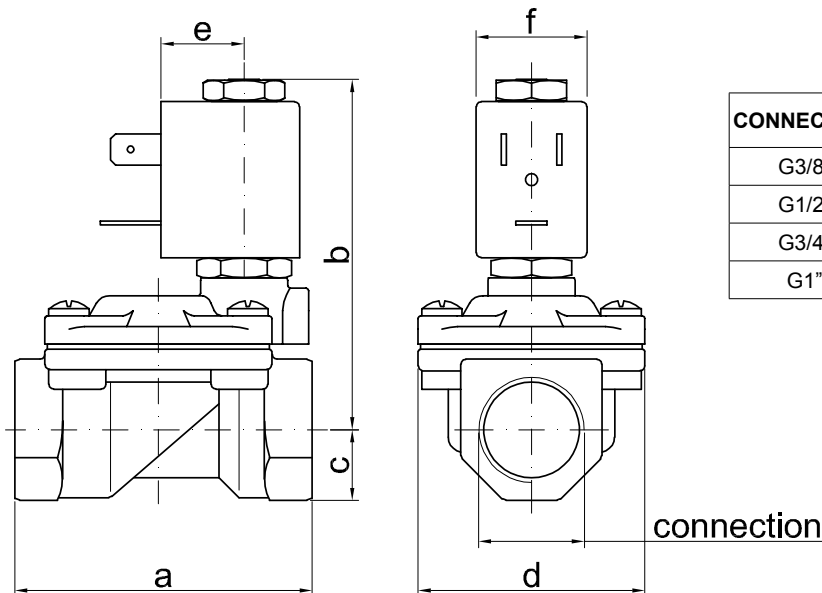

CONNECTION	a	b	c	d	e	f	weight Kg
G3/8"	59	70	11	45	16	22	0.30
G1/2"	59	70	13	45	16	22	0.32
G3/4"	79	76	18	55	16	22	0.55
G1"	96	85	20	72	16	22	0.95

**DESCRIPTION**

Solenoid valve 2 way normally closed in stainless steel AIS 316 with servo-assisted diaphragm.

With explosion proof coil certified for hazardous area:

**Ex** II 2GD Ex d IIC T6 or T5 or T4 Gb  
 Ex tb IIIC T80°C or T95°C or T130°C Db IP66  
 Tamb -10°C ÷ +35°C(T6) or +50°C(T5) or +60°C(T4)

(other certifications e.g. Gost-r, Baseefa, CCOE etc. on request)



**VALVE CONSTRUCTION**

Body Stainless steel  
 Seal material FPM, NBR

**EXPLOSION PROOF COIL CONSTRUCTION**

Housing Red colour alloy  
 Electrical connection 1/2" NPT

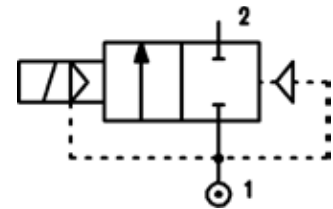

**4**

**FEATURES**

Minimum allowable pressure 0.15bar  
 Maximum allowable pressure 25bar  
 Maximum fluid viscosity 25cSt (mm<sup>2</sup>/s)  
 Ambient temperature: -10°C ÷ +35°C(T6), +50°C(T5), +60°C  
 Mounting position with vertical coil above

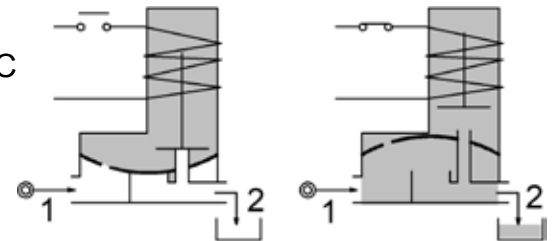

**OPTIONS:** Versions with slow closing diaphragm

**NOTE:** The solenoid valve is suitable only with media that are **NOT** potentially explosive

CODE ②	Connection G ISO 228	Orifice mm	Kv m <sup>3</sup> /h	Differential pressure bar			Nominal power		Coil Series	Seal	Temp. range °C
				Min	Max AC DC		AC Holding	DC			
A177CV12/1/...	1/4"	10	1.5	0.15	15	15	12 VA	8W	A6	FPM=V	-10 +140
A177DV12/1/...	3/8"	10	1.7	0.15	15	15					
A177EV18/1/...	3/8"	12	2.2	0.15	15	15					
A177FV25/1/...	1/2"	12	2.5	0.15	15	15					

② Coil

COILS	Alternating Current 50/60Hz Volt				Direct Current Volt			Electrical connection
	24	48	110	220 230	12	24	48	
Series A6 Code ②	A6B	A6C	A6D	A6E	A60	A61	A62	1/2" NPT

**DESCRIPTION**  
 Voltage tolerance  
 AC +15% -10%  
 DC ± 10%  
 Protection class IP66  
 Continuous service ED100%

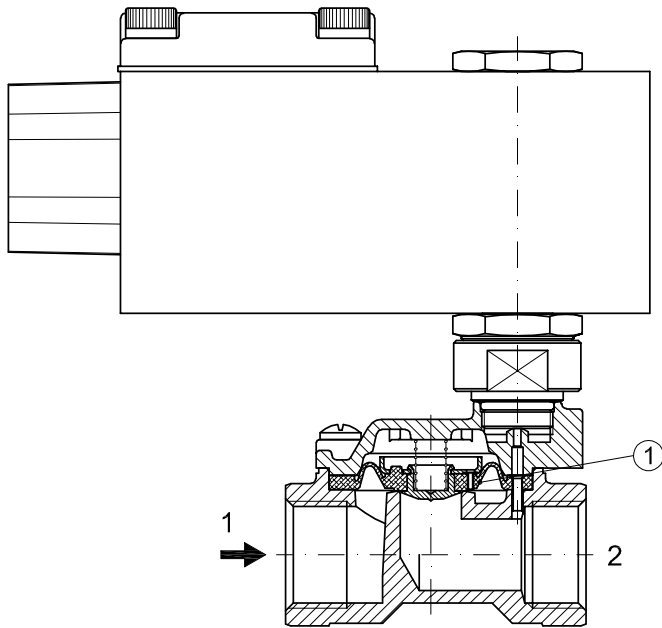

### OVERALL DIMENSION

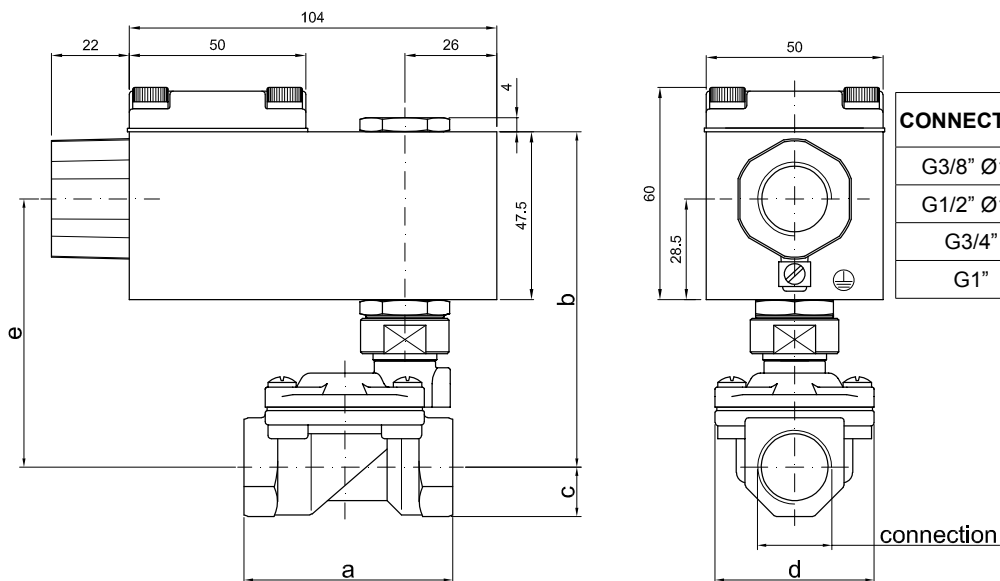

**DESCRIPTION**

Solenoid valve 2 way normally open with servo-assisted diaphragm

**CONSTRUCTION**

Body and cover	Brass
Armature tube	Stainless steel
Plunger and core	Stainless steel
Springs	Stainless steel
Seal material	NBR - FPM - EPDM



**FEATURES**

- Minimum differential pressure 0.15 bar
- Maximum allowable pressure\* 25 bar
- Maximum fluid viscosity 25cSt (mm<sup>2</sup>/s)
- Ambient temperature: with class F coil -10°C +55°C  
with class H coil -10°C +80°C
- Preferred mounting position with vertical coil above

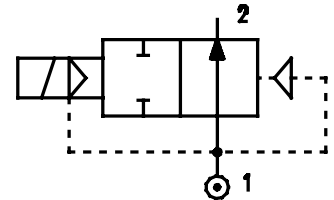

- OPTIONS:** Electroless nickel plating  
Series 7 explosion proof coil according to ATEX - EExmII  
 us certified coils

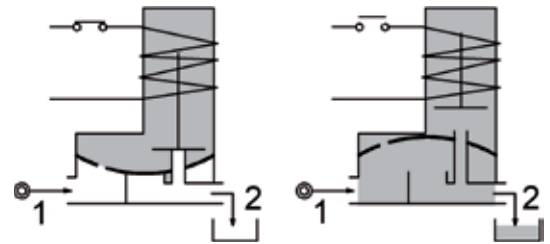

CODE ① ②	Connection G ISO 228	Orifice mm	Kv m <sup>3</sup> /h	Differential pressure bar			Nominal power			Coil		Seal ①	Temp. range °C
				Min	Max		AC Inrush	VA Holding	DC Watt	Series	Width		
					AC	DC							
E207B...10///...	1/4"	10	1.5	0.15	15	15	12	8	6.5	3	22	NBR=B	-10 +90
E207C...10///...	3/8"	10	1.7	0.15	15	15							
E207C...12///...	3/8"	12	2.2	0.15	15	15							
E207D...12///...	1/2"	12	2.5	0.15	15	15							
E207E...18///...	3/4"	18	5.5	0.15	13	13							
E207F...25///...	1"	25	10.2	0.15	10	10							
E207G...30///...	1" 1/4	30	15	0.15	10	10	FPM=V	-10 +140					

① Seal Example: E207DB12///301 NBR seal  
 ② Coil Coil 24V DC

COILS	Alternating Current 50/60Hz Volt							Direct Current Volt			Electrical connection	Connectors
	12	24	48	110	220 230	240	380	12	24	48		
Series 3 Width 22 Code ②	30A	30B	30C	30D	30E	30F	30G	300	301	302	DIN 46244	PG9 code 10348000

**DESCRIPTION**  
 Class F insulation  
 Voltage tolerance  
 AC +15% -10%  
 DC ± 10%  
 Protection class  
 IP65 with connector fitted  
 IP00 without connector  
 Continuous service ED100%

**OPTIONS**  
 Class H insulation  
 Cable attached  
 Special coil voltage  
 Special coil powers  
 cULus certified coils

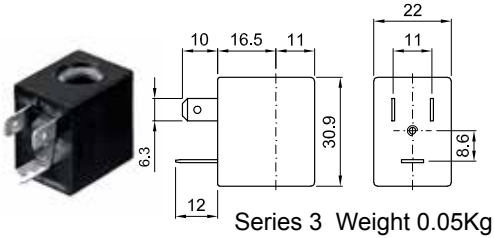

Series 3 Weight 0.05Kg

### SPARE PARTS LIST

1. Coil fixing nut
2. Coil
3. Seal assembly
4. Armature tube with core
5. Diaphragm assembly

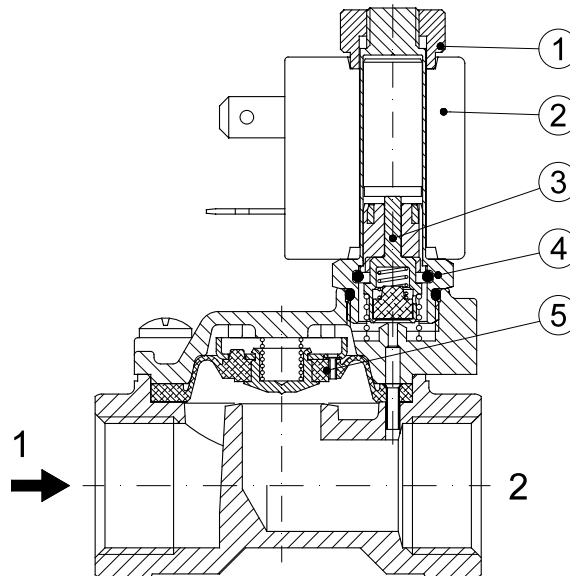

### OVERALL DIMENSION

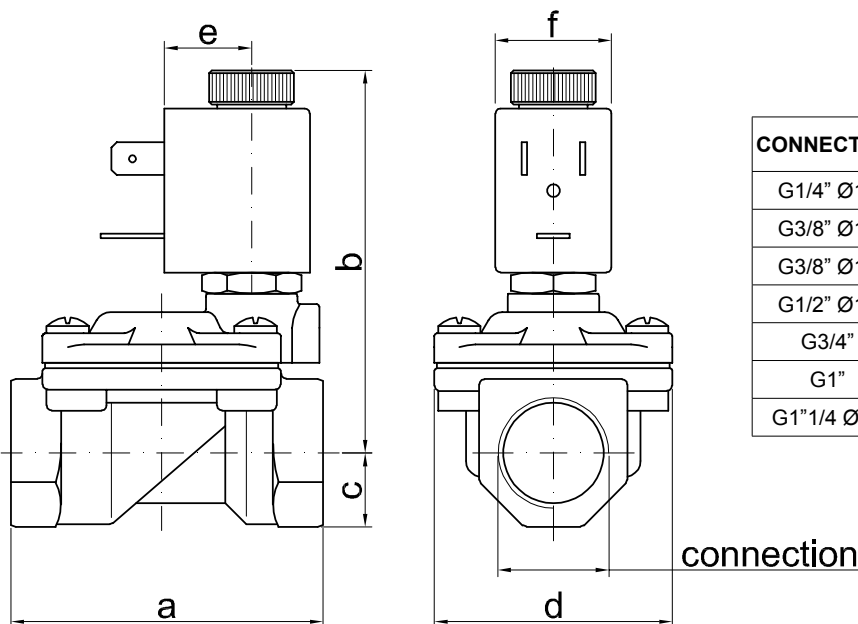

CONNECTION	a	b	c	d	e	f	weight Kg
G1/4" Ø10	49	65	11	32	16	22	0.23
G3/8" Ø10	49	65	11	32	16	22	0.24
G3/8" Ø12	59	73	14	45	16	22	0.42
G1/2" Ø12	59	73	14	45	16	22	0.39
G3/4"	79	76	18	55	16	22	0.65
G1"	96	85	20	72	16	22	1.05
G1 1/4 Ø30	119	96	25	85	16	22	1.70

**DESCRIPTION**

Solenoid valve 2 way normally open with servo-assisted diaphragm

**CONSTRUCTION**

Body and cover	Brass
Armature tube	Stainless steel
Plunger and core	Stainless steel
Springs	Stainless steel
Seal material	NBR - FPM - EPDM



**FEATURES**

- Minimum differential pressure 0.15÷3 bar
- Maximum allowable pressure\* 20 bar
- Maximum fluid viscosity 25cSt (mm<sup>2</sup>/s)
- Ambient temperature: with class F coil -10°C +55°C  
with class H coil -10°C +80°C
- Preferred mounting position with vertical coil above

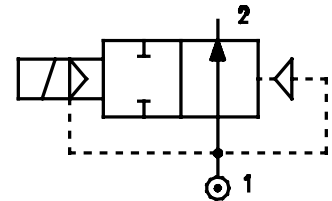

**4**

**OPTIONS:** Electroless nickel plating  
c us certified coils

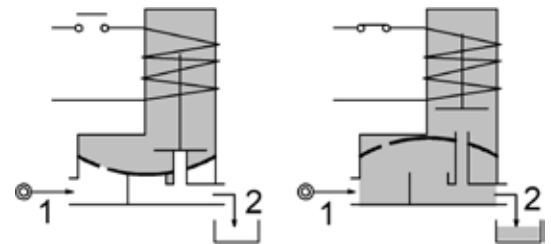

CODE ① ②	Connection G ISO 228	Orifice mm	Kv m <sup>3</sup> /h	Differential pressure bar			Nominal power			Coil		Seal ①	Temp. range °C
				Min	Max AC DC		AC Inrush	VA Holding	DC Watt	Series	Width		
E207G...37///...	1"1/4	37	18	0.15	10	10	20	15	10	2	30	NBR=B EPDM=E FPM=V	-10 +90 -10 +140 -10 +140
E207H...37///...	1"1/2	37	21	0.15	10	10							
E207I...50///...	2"	50	36	0.15	10	10							
E207MB75///...	2"1/2	75	75	0.3	5	5	20	15	10	2	30	NBR=B	-10 +90
E207RB75///...	3"	75	84	0.3	5	5							
③E207MB75/W/...	2"1/2	75	75	3	15	15	40	30	27	5	36	NBR=B	-10 +90
③E207RB75/W/...	3"	75	84	3	15	15							

- ① Seal
  - ② Coil
  - ③ Reinforced diaphragm
- Example: E207HB37///201 NBR seal  
Coil 24V DC

\* REMARK: The maximum allowable pressure PS for steam 2,5bar (gauge pressure)

COILS	Alternating Current 50/60Hz Volt							Direct Current Volt			Electrical connection	Connectors
	12	24	48	110	220 230	240	380	12	24	48		
Series 2 Width 30 Code ②	20A	20B	20C	20D	20E	20F	20G	200	201	202	DIN 43650A	PG9 code 10349000
Series 5 Width 36 Code ②	52A	52B	52C	52D	52E	52F	52G	520	521	522	DIN 43650A	PG11 code 10349001

**DESCRIPTION**  
 Insulation class  
 Series 2 =F Series 5=H  
 Voltage tolerance  
 AC +15% -10%  
 DC ± 10%  
 Protection class  
 IP65 with connector fitted  
 IP00 without connector  
 Continuous service ED100%

**OPTIONS**  
 Class H insulation (series 2)  
 Cable attached  
 Special coil voltage  
 Special coil powers  
 c us certified coils

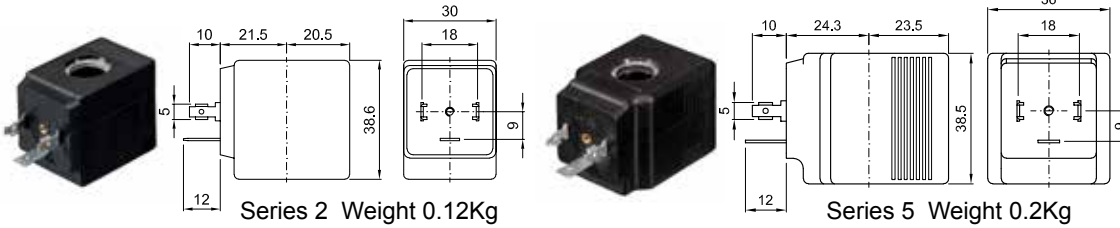

Series 2 Weight 0.12Kg

Series 5 Weight 0.2Kg

### SPARE PARTS LIST

1. Coil fixing nut
2. Coil
3. Seal assembly
4. Armature tube with core
5. Diaphragm assembly
6. Speed control valve
7. Water hammering reducer  
 $\varnothing 0.8-\varnothing 1-\varnothing 1.2$

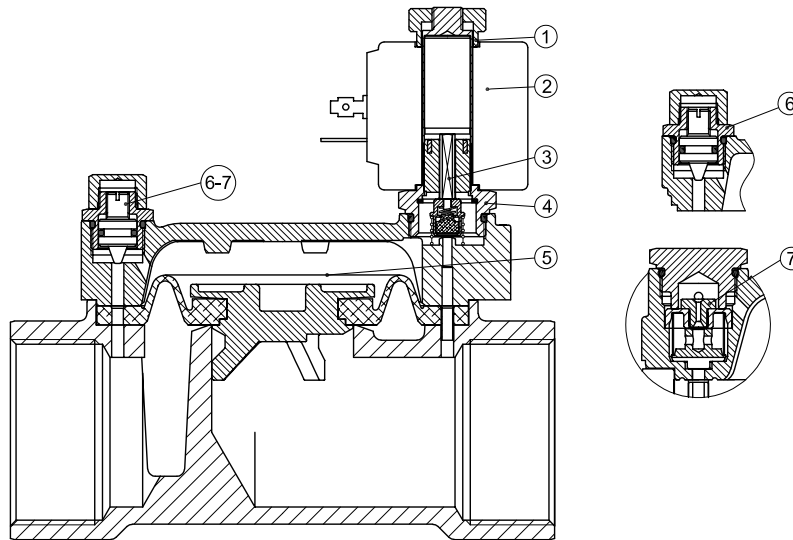

### OVERALL DIMENSION

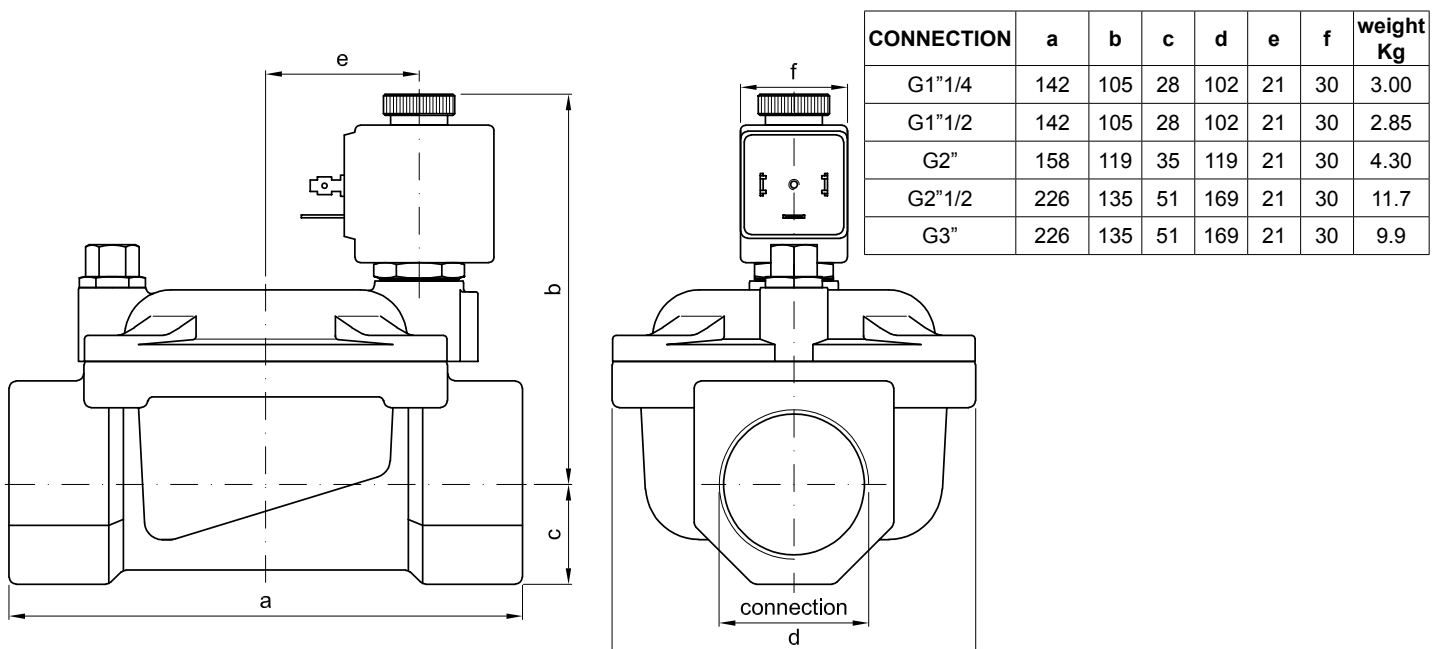



**DESCRIPTION**

Solenoid valve 2 way normally open with servo-assisted piston

**CONSTRUCTION**

Body and cover	Brass
Armature tube	Brass
Plunger and core	Stainless steel
Springs	Stainless steel
Piston	Brass
Piston seal	PTFE reinforced
Seal material	Main seal PTFE, other FPM



**FEATURES**

- Minimum differential pressure 1 bar
- Maximum allowable pressure 40 bar
- Maximum fluid viscosity 25cSt (mm<sup>2</sup>/s)
- Ambient temperature: with class F coil -10°C +55°C  
with class H coil -10°C +80°C
- Preferred mounting position with vertical coil above

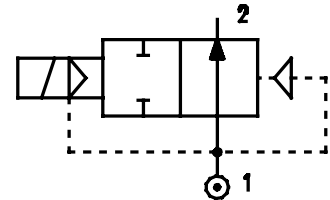

- OPTIONS:** Electroless nickel plating  
Stainless steel armature tube  
c us certified coils

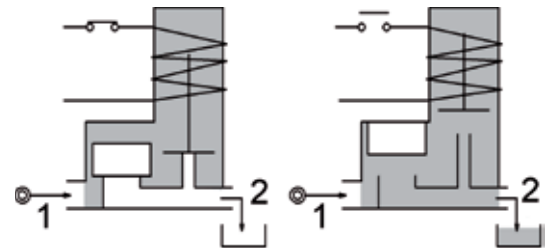

CODE ①	Connection G ISO 228	Orifice mm	Kv m <sup>3</sup> /h	Differential pressure bar			Nominal power			Coil		Seal	Temp. range °C
				Min	Max		AC Inrush	VA Holding	DC Watt	Series	Width		
					AC	DC							
E219CV12///...	3/8"	12	2	1	25	25	20	15	10	2	30	PTFE/ FPM	-10 +140
E219DV12///...	1/2"	12	2.2	1	25	25							

① Seal Example: E219DV12/1/521 FPM seal  
Coil 24V DC  
Maximum differential pressure 50bar

COILS	Alternating Current 50/60Hz Volt							Direct Current Volt			Electrical connection	Connectors
	12	24	48	110	220 230	240	380	12	24	48		
Series 2 Width 30 Code ②	20A	20B	20C	20D	20E	20F	20G	200	201	202	DIN 43650A	PG9 code 10349000

**DESCRIPTION**  
 Insulation class  
 Series 2 =F Series 5=H  
 Voltage tolerance  
 AC +15% -10%  
 DC ± 10%  
 Protection class  
 IP65 with connector fitted  
 IP00 without connector  
 Continuous service ED100%

**OPTIONS**  
 Class H insulation (series 2)  
 Cable attached  
 Special coil voltage  
 Special coil powers  
 US certified coils

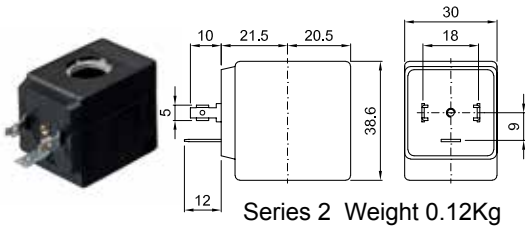

### SPARE PARTS LIST

1. Coil fixing nut
2. Coil
3. Seal assembly
4. Armature tube with core
5. Piston assembly

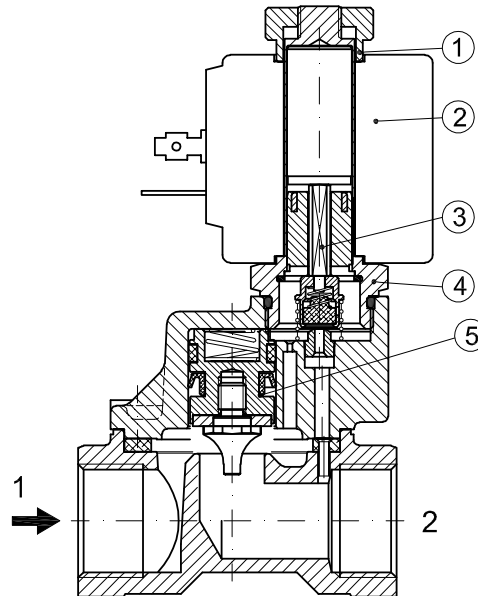

### OVERALL DIMENSION

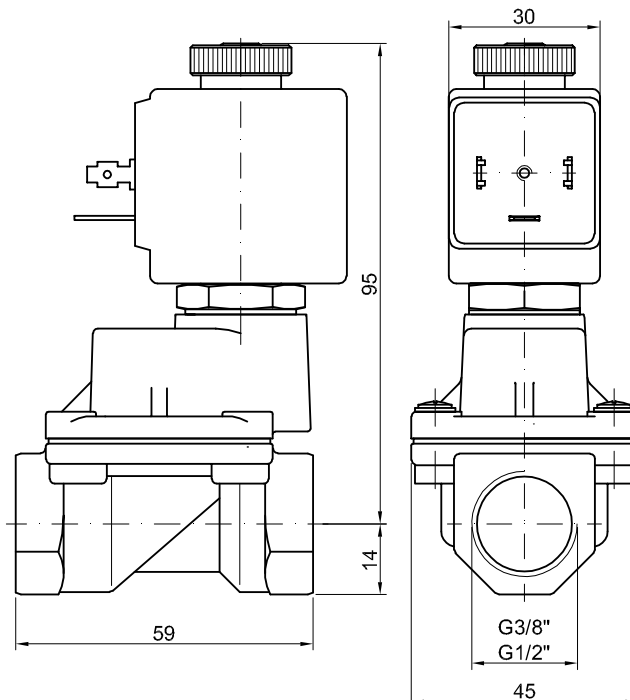

Weight=0.63Kg

**DESCRIPTION**

Solenoid valve 2 way normally open in stainless steel AISI 316 with servo-assisted diaphragm

**CONSTRUCTION**

Body and cover	Stainless steel
Armature tube	Stainless steel
Plunger and core	Stainless steel
Springs	Stainless steel
Seal material	NBR - FPM - EPDM



**FEATURES**

- Minimum differential pressure 0.15 bar
- Maximum allowable pressure\* 25 bar
- Maximum fluid viscosity 25cSt (mm<sup>2</sup>/s)
- Ambient temperature: with class F coil -10°C +55°C  
with class H coil -10°C +80°C
- Preferred mounting position with vertical coil above

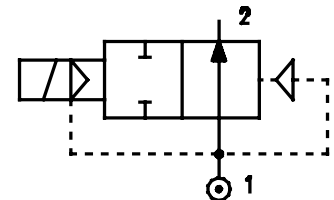

**4**

- OPTIONS:**
- Series 7 explosion proof coil according to ATEX - EExmII
  - Food approval seal material
  - Version with slow closing diaphragm
  - Version for use with oxygen
  - Silver shading ring
  - c us certified coils

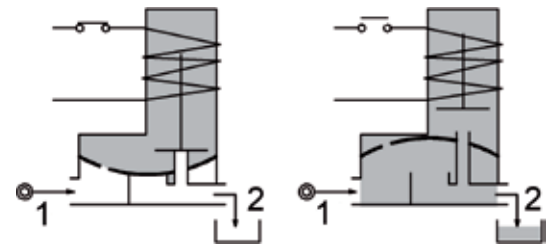

CODE ① ②	Connection G ISO 228	Orifice mm	Kv m <sup>3</sup> /h	Differential pressure bar			Nominal power			Coil		Seal ①	Temp. range °C
				Min	Max		AC Inrush	VA Holding	DC Watt	Series	Width		
					AC	DC							
E277C...12///...	3/8"	12	2.2	0.15	15	15	12	8	6.5	3	22	NBR=B	-10 +90
E277D...12///...	1/2"	12	2.5	0.15	15	15						EPDM=E	-10 +140
E277E...18///...	3/4"	18	5.5	0.15	13	13						FPM=V	-10 +140
E277F...25///...	1"	25	10.2	0.15	10	10							

- ① Seal
- ② Coil

Example: E277DB12///301 NBR seal  
Coil 24V DC

COILS	Alternating Current 50/60Hz Volt							Direct Current Volt			Electrical connection	Connectors
	12	24	48	110	220 230	240	380	12	24	48		
Series 3 Width 22 Code ②	30A	30B	30C	30D	30E	30F	30G	300	301	302	DIN 46244	PG9 code 10348000

**DESCRIPTION**  
 Class F insulation  
 Voltage tolerance  
 AC +15% -10%  
 DC ± 10%  
 Protection class  
 IP65 with connector fitted  
 IP00 without connector  
 Continuous service ED100%

**OPTIONS**  
 Class H insulation  
 Cable attached  
 Special coil voltage  
 Special coil powers  
 cULus certified coils

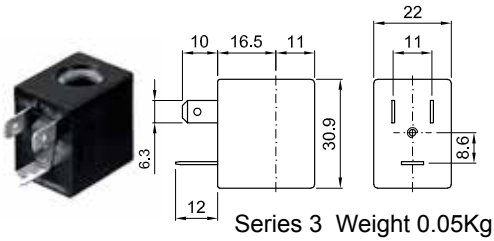

### SPARE PARTS LIST

1. Coil fixing nut
2. Coil
3. Seal assembly
4. Armature tube with core
5. Diaphragm assembly

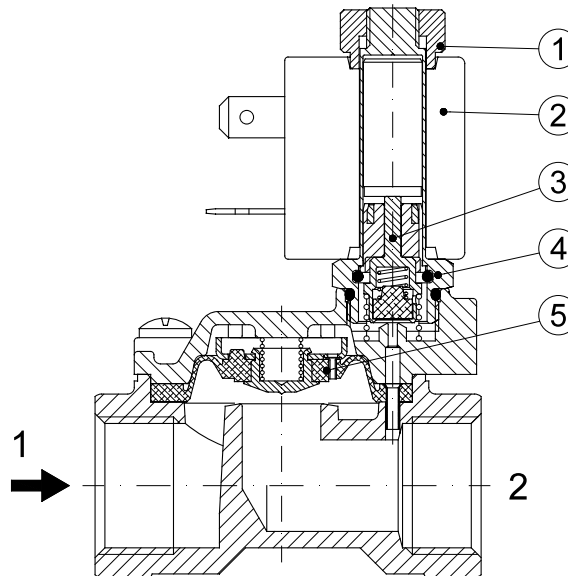

### OVERALL DIMENSION

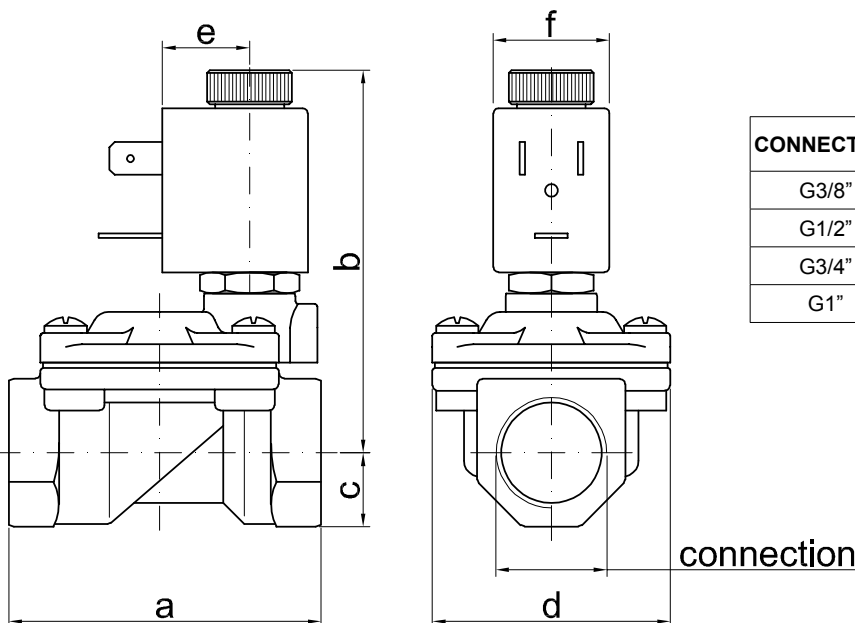

CONNECTION	a	b	c	d	e	f	weight Kg
G3/8"	59	73	14	45	16	22	0.30
G1/2"	59	73	14	45	16	22	0.32
G3/4"	79	76	18	55	16	22	0.55
G1"	96	85	20	72	16	22	0.95

**DESCRIPTION**

2 way normally closed angle seat valve pneumatically operated

**PRESENTATION**

- High flow rate due to the angle seat configuration
- Anti-water hammer feature with the fluid entry below the seat
- Stainless steel and corrosion resistance body
- Orientable pneumatic actuator
- Self adjusting internal seal
- Optical position indicator
- Back pressure resistance capability
- Maintenance free sealing pack
- Universal mounting position



**USE:** Automation, heating, water, hot water, steam (180°C), aggressive and food fluid

**CONNECTION:** from 1/2" to 1" GAS or NPT

**VALVE FEATURES**

Fluid temperature	-40°C +180°C
Ambient temperature	-10°C +80°C
Fluid viscosity	max 600 cSt
Body material	Stainless steel AISI 316
Seal	PTFE
Packing gland	PTFE/FKM

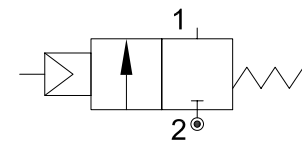

**5**

**PILOT ACTUATOR FEATURES**

Fluid	Dry or lubricated air, gases and neutral fluids
Fluid temperatures	max +60°C
Body material	Stainless steel AISI 316
Gaskets	NBR
Actuator	Ø50

CODE ①	Connection GAS - NPT	Orifice mm	Kv l/min	Actuator pilot pressure (bar)		Differential pressure MOPD (bar)		Max allowable pressure PS (bar)	Weight Kg
				min	max	min	max		
P150D...W15/V	1/2"	15	80	5	8	0	25	40	1.6
P150E...W20/V	3/4"	20	150				15		1.7
P150F...W25/V	1"	25	190				10		2.1

① G= GAS (ISO228/1)  
N= NPT (ANSI/ASME B1.20.1)

Ordination example: P150FGW25/V connection G1"

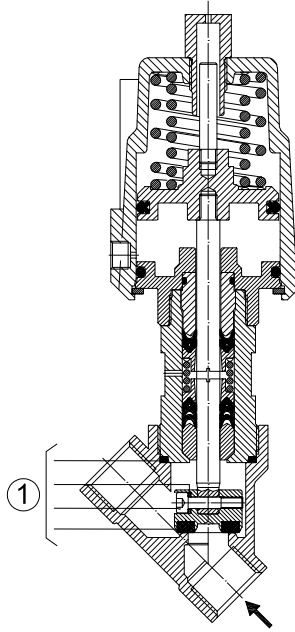

### MAINTENANCE KIT

- 1. 1/2" R500078
- 3/4" R500081
- 1" R500084

### OVERALL DIMENSION

CONNECTION GAS or NPT	A mm	B mm	C mm	D mm	H mm	L mm	T mm
1/2"	190.6	SW 27	156	15.4	139.7	65	17
3/4"	190.8	SW 32	162	21.4	139.8	75	19
1"	200.3	SW 41	168	25	146.6	90	20.5

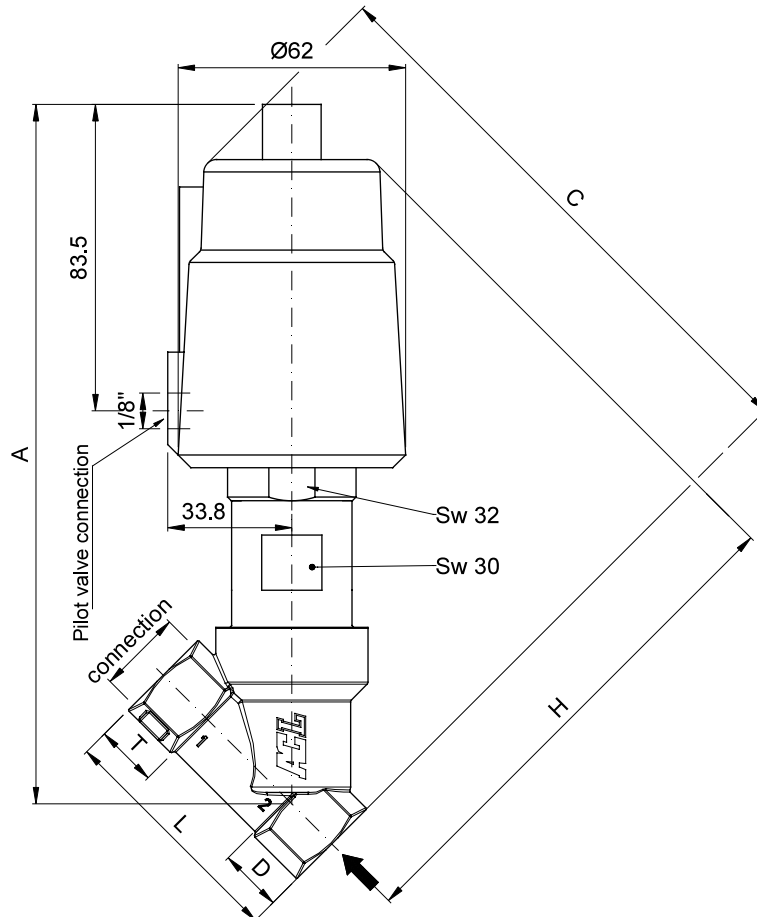

**DESCRIPTION**

2 way proportional angle seat valve pneumatically operated

**PRESENTATION**

- High flow rate due to the angle seat configuration
- Anti-water hammer feature with the fluid entry below the seat
- Stainless steel and corrosion resistance body
- Orientable pneumatic actuator
- Self adjusting internal seal
- Optical position indicator
- Back pressure resistance capability
- Maintenance free sealing pack
- Accurated flow control
- Universal mounting position



**USE:** Automation, heating, water, hot water, steam (180°C), aggressive and food fluid

**CONNECTION:** from 1/2" to 1" GAS or NPT

**VALVE FEATURES**

Fluid temperature	-40°C +180°C
Ambient temperature	-10°C +80°C
Fluid viscosity	max 600 cSt
Body material	Stainless steel AISI 316
Seal	PTFE
Packing gland	PTFE/FKM

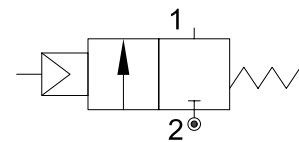

**5**

**PILOT ACTUATOR FEATURES**

Fluid	Dry or lubricated air, gases and neutral fluids
Fluid temperatures	max +60°C
Body material	Stainless steel AISI 316
Gaskets	NBR
Actuator	Ø50

CODE ①	Connection GAS - NPT	Orifice mm	Kv l/min	Actuator pilot pressure (bar)		Differential pressure MOPD (bar)		Max allowable pressure PS (bar)	Weight Kg
				min	max	min	max		
P152D...W15/V	1/2"	15	70	0	8	0	16	40	1.6
P152E...W20/V	3/4"	20	110				10		1.7
P152F...W25/V	1"	25	130				10		2.1

① G= GAS (ISO228/1) Ordination example: P152ENW20/V connection 3/4" NPT  
 N= NPT (ANSI/ASMI BI.20.1)

Flow factor - Fluid +20°C

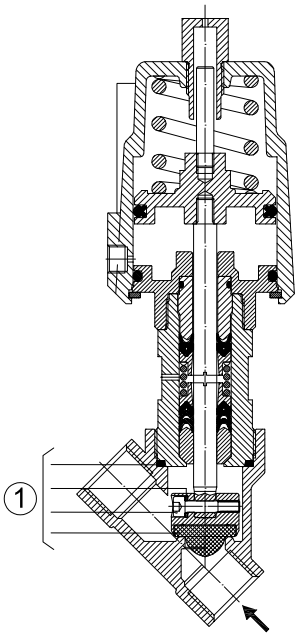

### MAINTENANCE KIT

- 1. 1/2" R500078
- 3/4" R500081
- 1" R500084

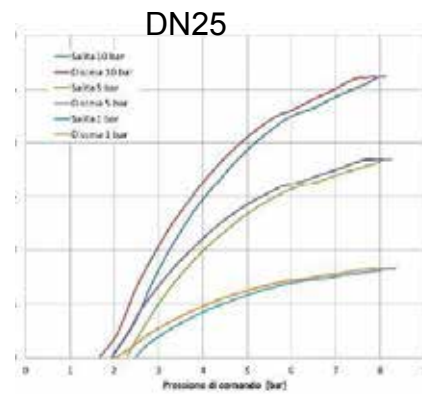
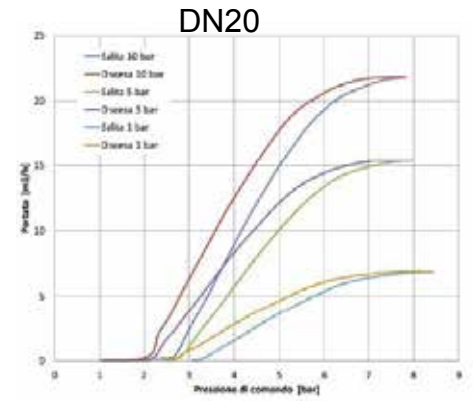
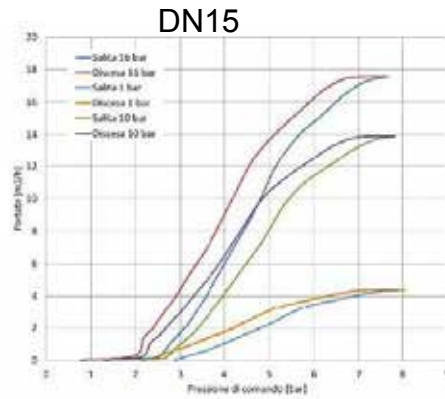

### OVERALL DIMENSION

CONNECTION GAS or NPT	A mm	B mm	C mm	D mm	H mm	L mm	T mm
1/2"	190.6	Ch 27	156	15.4	139.7	65	17
3/4"	190.8	Ch 32	162	21.4	139.8	75	19
1"	200.3	Ch 41	168	25	146.6	90	20.5

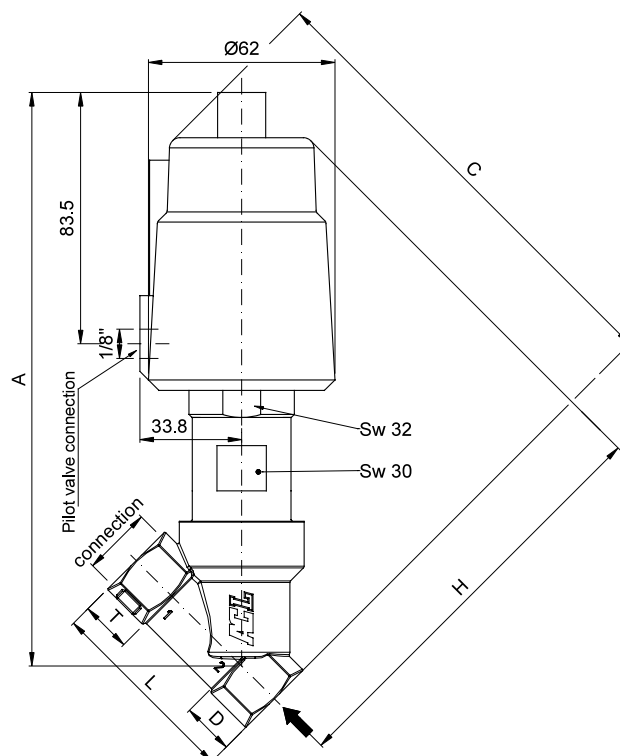



**DESCRIPTION**

2 way normally closed angle seat valve pneumatically operated

**PRESENTATION**

- High flow rate due to the angle seat configuration
- Anti-water hammer feature with the fluid entry below the seat
- Stainless steel and corrosion resistance body
- Orientable pneumatic actuator
- Self adjusting internal seal
- Optical position indicator
- Back pressure resistance capability
- Maintenance free sealing pack
- Universal mounting position



**USE:** Automation, heating, water, hot water, steam (180°C), aggressive and food fluid

**CONNECTION:** from 1/2" to 2" GAS o NPT

**VALVE FEATURES**

Fluid temperature	-40°C +180°C
Ambient temperature	-10°C +80°C
Fluid viscosity	max 600 cSt
Body material	Stainless steel AISI 316
Seal	PTFE
Packing gland	PTFE/FKM

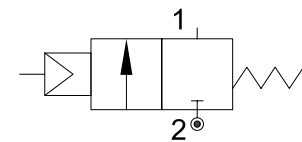

**5**

**PILOT ACTUATOR FEATURES**

Fluid	Dry or lubricated air, gases and neutral fluids
Fluid temperatures	max +60°C
Body material	Polyamide 66 with 30% glass fibre
Gaskets	NBR
Actuator	Ø70

CODE ①	Connection GAS - NPT	Orifice mm	Kv l/min	Actuator pilot pressure (bar)		Differential pressure MOPD (bar)		Max allowable pressure PS (bar)	Weight Kg
				min	max	min	max		
P170D...W15/V	1/2"	15	80	4	10	0	16	40	1.4
P170E...W20/V	3/4"	20	150				10		1.5
P170F...W25/V	1"	25	190				10		1.8
P170G...W32/V	1"1/4	32	340				7	25	2.4
P170H...W40/V	1"1/2	40	430				4.5		2.7
P170I...W50/V	2"	50	620				3	16	3.9

① G= GAS (ISO228/1)      Ordination example: P170FGW25/V connection G1"  
 N= NPT (ANSI/ASMI BI.20.1)



CE Approval

(Pressure equipment directive 2014/68/UE)  
 for valves P170G\_W32 - P170H\_W40 - P170I\_W50

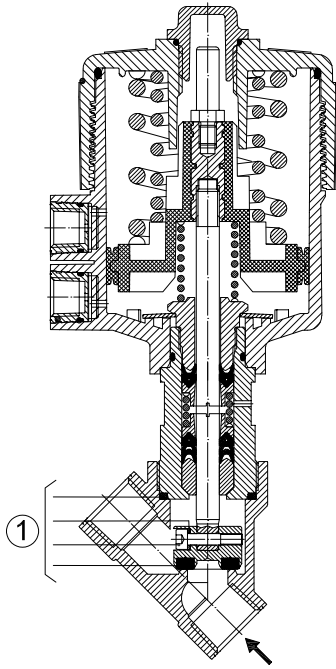

### MAINTENANCE KIT

- 1. 1/2" R500045
- 3/4" R500048
- 1" R500051
- 1"1/4 R500054
- 1"1/2 R500057
- 2" R500075

### OVERALL DIMENSION

CONNECTION GAS or NPT	A mm	B mm	C mm	D mm	H mm	L mm	T mm
1/2"	206.8	SW 27	178.7	15.4	163.3	65	17
3/4"	211.7	SW 32	188.6	21.9	166.7	75.5	19
1"	220.1	SW 41	197.8	25.1	172.7	90	21
1" 1/4	235.9	SW 50	212.3	28.5	183.8	110	24
1" 1/2	238.9	SW 55	217.0	31.0	186	122	25.2
2"	247.8	SW 70	229.7	37.5	192.2	151	28.5

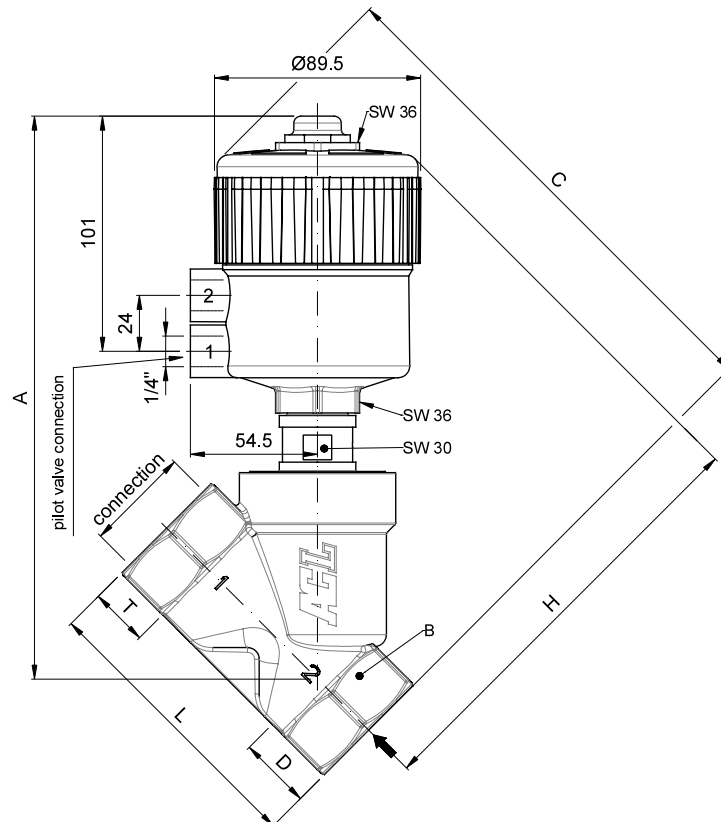

**DESCRIPTION**

2 way normally closed angle seat valve pneumatically operated for high pressure

**PRESENTATION**

- High flow rate due to the angle seat configuration
- Anti-water hammer feature with the fluid entry below the seat
- Stainless steel and corrosion resistance body
- Orientable pneumatic actuator
- Self adjusting internal seal
- Optical position indicator
- Back pressure resistance capability
- Maintenance free sealing pack
- Universal mounting position



**USE:** Automation, heating, water, hot water, steam (180°C), aggressive and food fluid

**CONNECTION:** from 1/2" to 2" GAS o NPT

**VALVE FEATURES**

Fluid temperature	-40°C +180°C
Ambient temperature	-10°C +80°C
Fluid viscosity	max 600 cSt
Body material	Stainless steel AISI 316
Seal	PTFE
Packing gland	PTFE/FKM

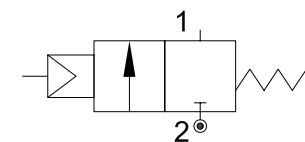

**5**

**PILOT ACTUATOR FEATURES**

Fluid	Dry or lubricated air, gases and neutral fluids
Fluid temperatures	max +60°C
Body material	Polyamide 66 with 30% glass fibre
Gaskets	NBR
Actuator	Ø70

CODE ①	Connection GAS - NPT	Orifice mm	Kv l/min	Actuator pilot pressure (bar)		Differential pressure MOPD (bar)		Max allowable pressure PS (bar)	Weight Kg
				min	max	min	max		
P171D...W15/V	1/2"	15	80	4	10	0	35	40	1.4
P171E...W20/V	3/4"	20	150				25		1.5
P171F...W25/V	1"	25	190				20		1.8
P171G...W32/V	1"1/4	32	340				13	2.4	
P171H...W40/V	1"1/2	40	430				8		2.7
P171I...W50/V	2"	50	620				5.5	16	3.9

① G= GAS (ISO228/1) Ordination example: P171FGW25/V connection G1"  
N= NPT (ANSI/ASMI BI.20.1)



CE Approval

(Pressure equipment directive 2014/68/UE)  
for valves P171G\_W32 - P171H\_W40 - P171I\_W50

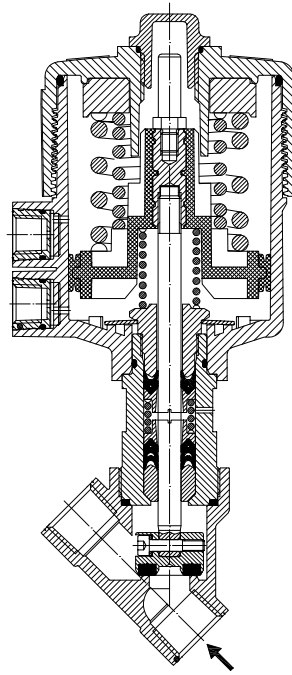

**OVERALL DIMENSION**

CONNECTION GAS or NPT	A mm	B mm	C mm	D mm	H mm	L mm	T mm
1/2"	206.8	SW 27	178.7	15.4	163.3	65	17
3/4"	211.7	SW 32	188.6	21.9	166.7	75.5	19
1"	220.1	SW 41	197.8	25.1	172.7	90	21
1" 1/4	235.9	SW 50	212.3	28.5	183.8	110	24
1" 1/2	238.9	SW 55	217.0	31.0	186	122	25.2
2"	247.8	SW 70	229.7	37.5	192.2	151	28.5

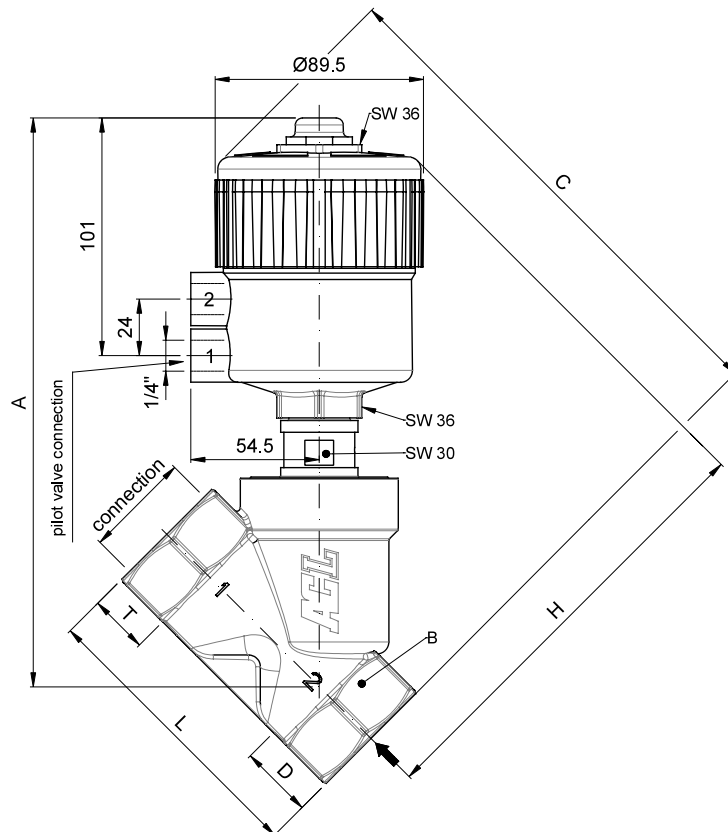

## DESCRIPTION

2 way proportional angle seat valve pneumatically operated

## PRESENTATION

- High flow rate due to the angle seat configuration
- Anti-water hammer feature with the fluid entry below the seat
- Stainless steel and corrosion resistance body
- Orientable pneumatic actuator
- Self adjusting internal seal
- Optical position indicator
- Back pressure resistance capability
- Maintenance free sealing pack
- Accurate flow control
- Universal mounting position



**USE:** Automation, heating, water, hot water, steam (180°C), aggressive and food fluid

**CONNECTION:** from 1/2" to 2" GAS o NPT

## VALVE FEATURES

Fluid temperature	-40°C +180°C
Ambient temperature	-10°C +80°C
Fluid viscosity	max 600 cSt
Body material	Stainless steel AISI 316
Seal	PTFE
Packing gland	PTFE/FKM

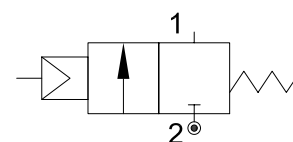

**5**

## PILOT ACTUATOR FEATURES

Fluid	Dry or lubricated air, gases and neutral fluids
Fluid temperatures	max +60°C
Body material	Polyamide 66 with 30% glass fibre
Gaskets	NBR
Actuator	Ø70

CODE ①	Connection	Orifice mm	Kv l/min	Actuator pilot pressure (bar)		Differential pressure MOPD (bar)		Max allowable pressure PS (bar)	Weight Kg
	GAS - NPT			min	max	min	max		
P172D...W15/V	1/2"	15	70	0	10	0	16	40	1.4
P172E...W20/V	3/4"	20	130				10		1.5
P172F...W25/V	1"	25	150				10		1.8

① G= GAS (ISO228/1)  
N= NPT (ANSI/ASME B1.20.1)

Ordination example: P172ENW20/V connection 3/4" NPT

Flow factor - Fluid +20°C

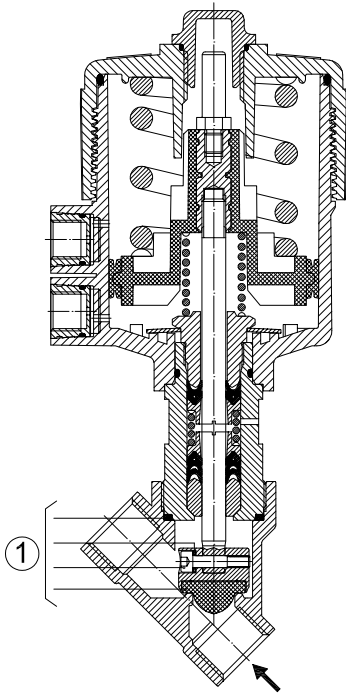

DN15

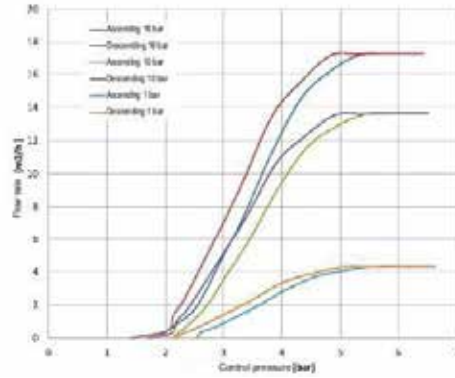

DN20

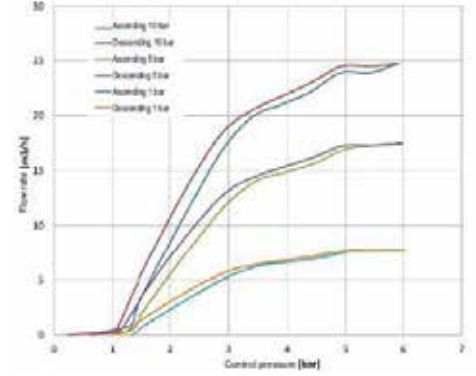

DN25

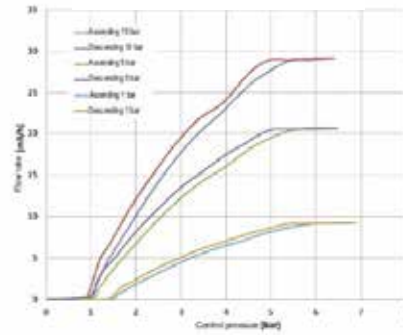

**MAINTENANCE KIT**

- 1. 1/2" R500078
- 3/4" R500081
- 1" R500084

**OVERALL DIMENSION**

CONNECTION GAS or NPT	A mm	B mm	C mm	D mm	H mm	L mm	T mm
1/2"	206.8	SW 27	178.7	15.4	163.3	65	17
3/4"	211.7	SW 32	188.6	21.9	166.7	75.5	19
1"	220.1	SW 41	197.8	25.1	172.7	90	21

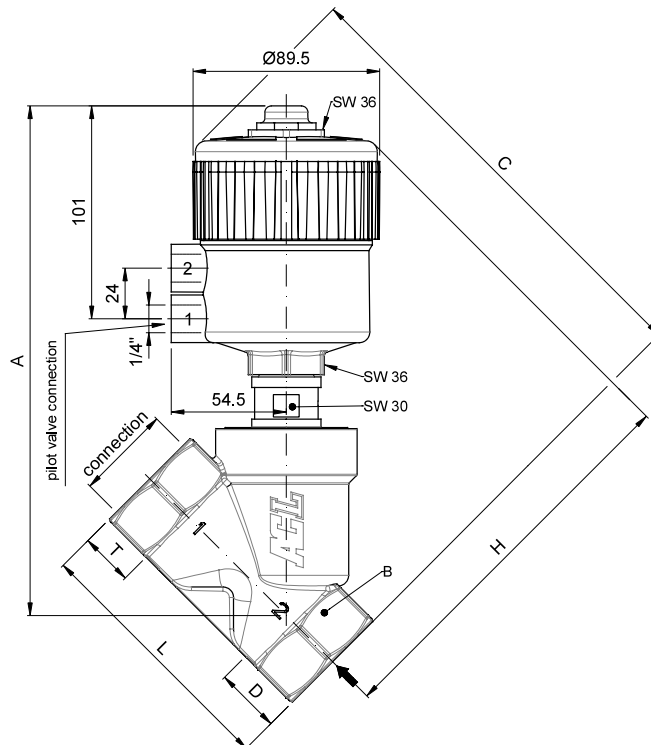

**DESCRIPTION**

2 way normally open angle seat valve pneumatically operated

**PRESENTATION**

- High flow rate due to the angle seat configuration
- Anti-water hammer feature with the fluid entry below the seat
- Stainless steel and corrosion resistance body
- Orientable pneumatic actuator
- Self adjusting internal seal
- Optical position indicator
- Back pressure resistance capability
- Maintenance free sealing pack
- Universal mounting position



**USE:** Automation, heating, water, hot water, steam (180°C), aggressive and food fluid

**CONNECTION:** from 1/2" to 2" GAS o NPT

**VALVE FEATURES**

Fluid temperature	-40°C +180°C
Ambient temperature	-10°C +80°C
Fluid viscosity	max 600 cSt
Body material	Stainless steel AISI 316
Seal	PTFE
Packing gland	PTFE/FKM

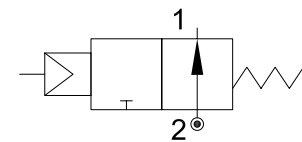

**5**

**PILOT ACTUATOR FEATURES**

Fluid	Dry or lubricated air, gases and neutral fluids
Fluid temperatures	max +60°C
Body material	Polyamide 66 with 30% glass fibre
Gaskets	NBR
Actuator	Ø70

CODE ①	Connection GAS - NPT	Orifice mm	Kv l/min	Actuator pilot pressure (bar)		Differential pressure MOPD (bar)		Max allowable pressure PS (bar)	Weight Kg
				min	max	min	max		
P270D...W15/V	1/2"	15	80	1.5	10	0	see pressure table  (next page)	40	1.4
P270E...W20/V	3/4"	20	150						1.5
P270F...W25/V	1"	25	190						1.8
P270G...W32/V	1"1/4	32	340					2.4	
P270H...W40/V	1"1/2	40	430					2.7	
P270I...W50/V	2"	50	620					3.9	

① G= GAS (ISO228/1) Ordination example: P270FGW25/V connection G1"  
N= NPT (ANSI/ASMI BI.20.1)



CE Approval

(Pressure equipment directive 2014/68/UE)  
for valves P270G\_W32 - P270H\_W40 - P270I\_W50

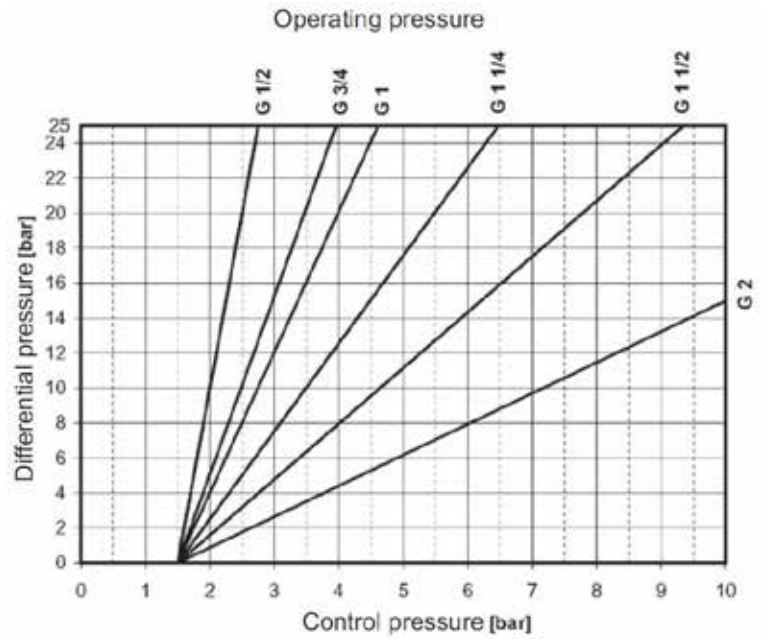
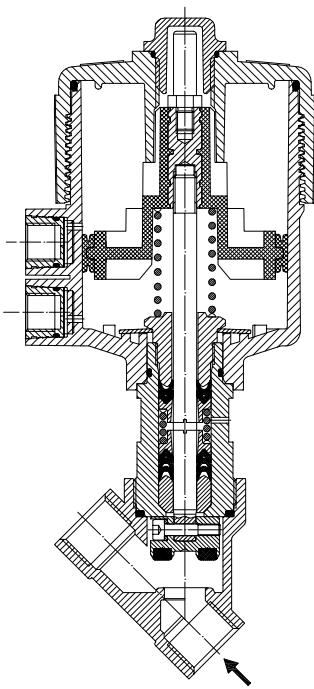

**OVERALL DIMENSION**

CONNECTION GAS or NPT	A mm	B mm	C mm	D mm	H mm	L mm	T mm
1/2"	206.8	SW 27	178.7	15.4	163.3	65	17
3/4"	211.7	SW 32	188.6	21.9	166.7	75.5	19
1"	220.1	SW 41	197.8	25.1	172.7	90	21
1" 1/4	235.9	SW 50	212.3	28.5	183.8	110	24
1" 1/2	238.9	SW 55	217.0	31.0	186	122	25.2
2"	247.8	SW 70	229.7	37.5	192.2	151	28.5

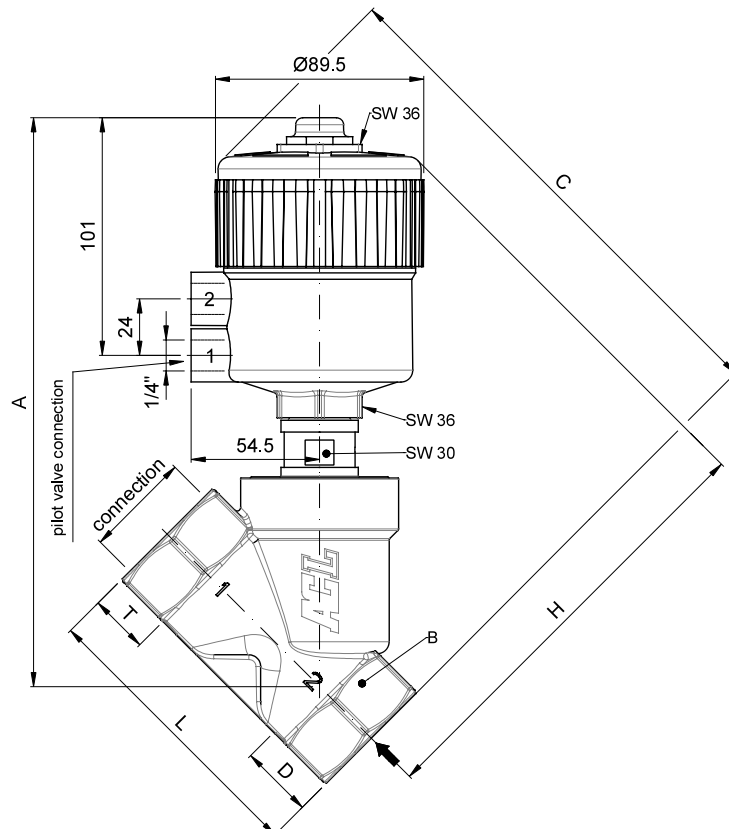



**DESCRIPTION**

Solenoid operated pinch valve with dry armature.  
 The tube is the only part in contact with the fluid.  
 The internal diameter determines the flow.  
 Elimination of dirt traps.  
 Fluid flow can be bi-directional.  
 Use soft tube (not supplied) hardness 50°Sh A ±3°



**CONSTRUCTION**

Body	Anodized aluminium
Pinching device	Acetal copolymer
Armature tube	Nickel plated brass
Plunger and core	Stainless steel
Springs	Stainless steel
Flange	Stainless steel

**FEATURES**

Ambient temperature: -10°C +40°C  
 Maximum fluid viscosity 65cSt (mm<sup>2</sup>/s)  
 Preferred mounting position with vertical coil above

**NOTE:** the right operating of the solenoid valve depends from a correct choice of the soft tube

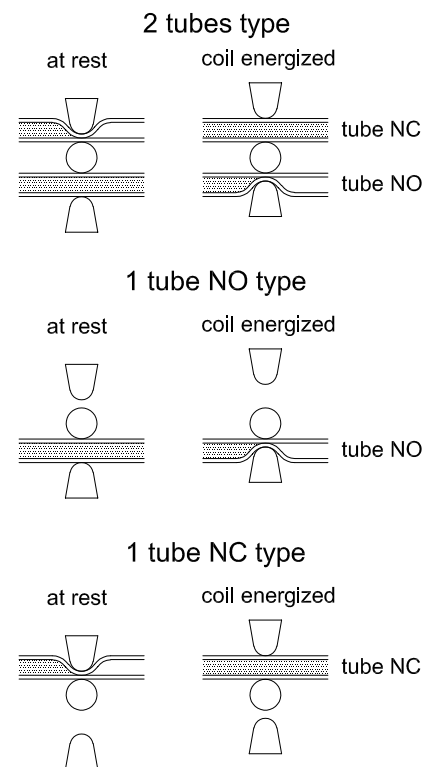

CODE ①	Tube		Pinch force gr	Version	Coil		Nominal power W
	Øext <sup>+0.2</sup> / <sub>-0</sub>	Min. wall thickness mm			Width	Series	
D730/30/...	3	0.7	250	2 tubes 1NC-1NO	16	6	8
D710/30/...	3	0.4	250	1 tube NC	16	6	4
D720/30/...	3	0.7	250	1 tube NO	16	6	4

① Coil

Example: D730/30/60048  
 Version with 2 tubes 12V DC 8W ED25%

COILS	Direct Current				Electrical connection	Connectors
	12V		24V			
	4W	8W	4W	8W		
Series 6 Width 16 Code ②	60014	60048	60114	60148	AMP 2.8x0.5	PG7 code 10348040

**DESCRIPTION**  
 Class F insulation  
 Voltage tolerance  $\pm 5\%$   
 Protection class  
 IP65 with connector fitted  
 IP00 without connector  
 Continuous service ED100%

**OPTIONS**  
 Cable attached  
 Special coil voltage  
 Special coil powers

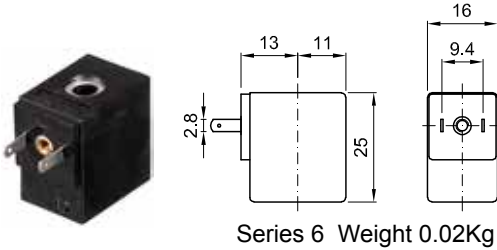

Series 6 Weight 0.02Kg

### SPARE PARTS LIST

1. Clip
2. Coil

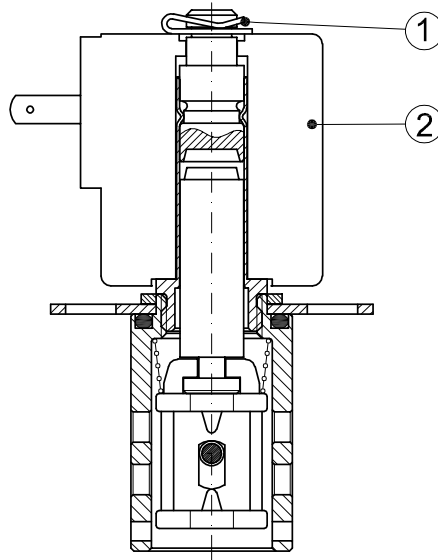

### OVERALL DIMENSION

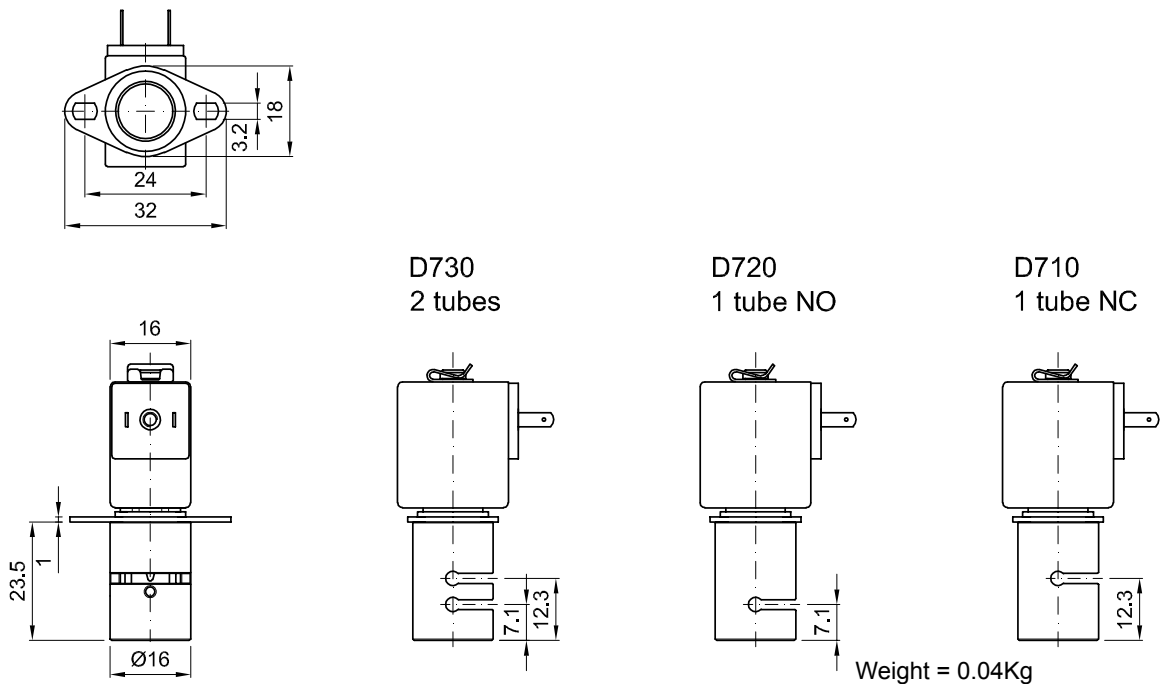

**DESCRIPTION**

Solenoid pilot 2 way normally closed. Tube Ø10.

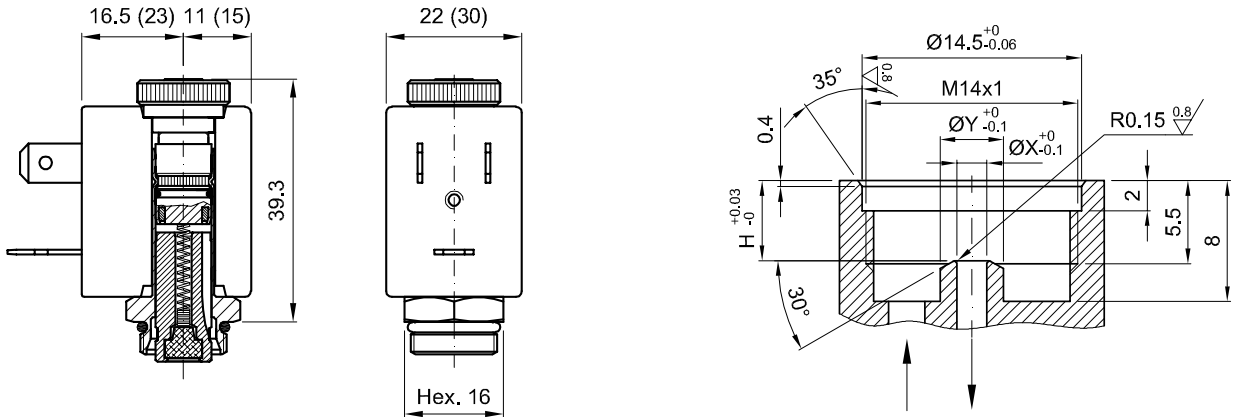

The quote in parenthesis are referred to the coil series 4

CODE		ØX mm	H mm	Differential pressure bar			Nominal power			Coil		Seal ①	Temp. range °C
Brass Tube	S.Steel Tube			Min	Max		AC Inrush	VA Holding	DC Watt	Series	Width		
E510...	E512...	1.2	5	0	25	25	12	8	6.5	3	22	NBR=B	-10 +90
		1.5	5.1	0	16	16							
		2	5.2	0	12	10							
		2.5	5.4	0	8	5.5							
		3.1	5.5	0	5	2							
E510...40	E512...40	4	5.6	0	4	1.5	15	11	5	4	30	FPM=V	-10 +140
E510...	E512...	2	5.2	0	25	15							
		2.5	5.4	0	16	8							
		3.1	5.5	0	8	4							
E510...40	E512...40	4	5.6	0	5	2.5							

**DESCRIPTION**

Solenoid pilot 2 way normally open. Tube Ø10.

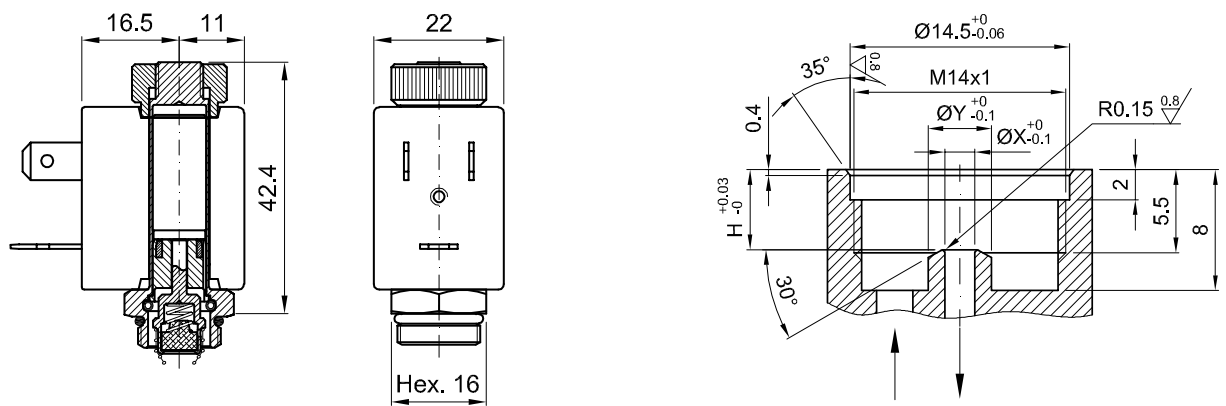

CODE		ØX mm	H mm	Differential pressure bar			Nominal power			Coil		Seal ①	Temp. range °C	
Brass Tube	S.Steel Tube			Min	Max		AC Inrush	VA Holding	DC Watt	Series	Width			
E520...	E522...	1.2	5	0	19	19	12	8	6.5	3	22	NBR=B	-10 +90	
		1.5	5.1	0	14	14								
		2	5.2	0	8	8								
		2.5	5.4	0	4.5	4.5								
		3.1	5.5	0	2.5	2.5								
													FPM=V	-10 +140

**DESCRIPTION**

Solenoid pilot 3 way normally closed. Tube Ø10.

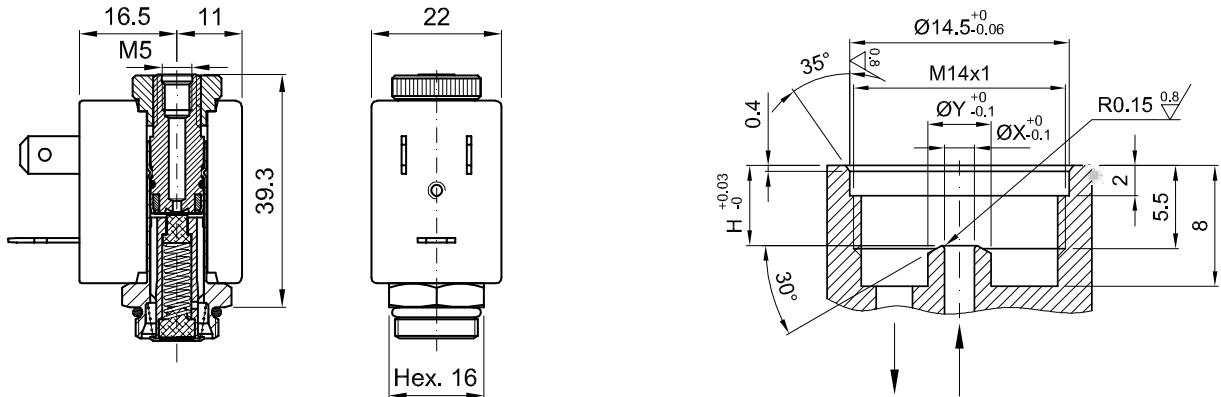

CODE		ØX mm	Øexh. mm	H mm	Differential pressure bar			Nominal power			Coil		Seal ①	Temp. range °C
Brass Tube	S.Steel Tube				Min	Max		AC Inrush	VA Holding	DC Watt	Series	Width		
E530...	E532...	1.2	1.5	5	0	15	15	12	8	6.5	3	22	NBR=B EPDM=E FPM=V	-10 +90 -10 +140 -10 +140
		1.5	1.5	5.1	0	10	10							
		2	1.7	5.2	0	6	6							

**DESCRIPTION**

Solenoid pilot 3 way normally open. Tube Ø10.

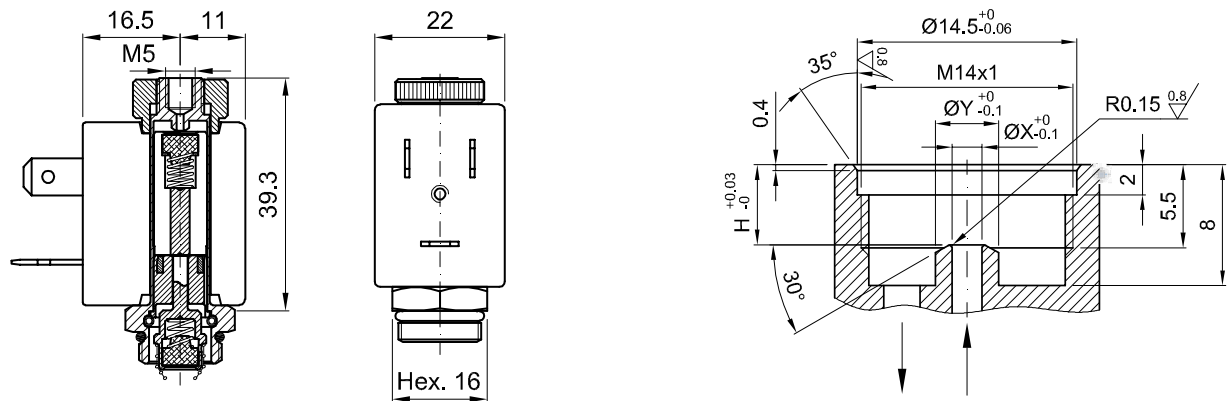

CODE		ØX mm	Øexh. mm	H mm	Differential pressure bar			Nominal power			Coil		Seal ①	Temp. range °C
Brass Tube	S.Steel Tube				Min	Max		AC Inrush	VA Holding	DC Watt	Series	Width		
E540...		1.2	1.5	5	0	12	8	12	8	6.5	3	22	NBR=B EPDM=E FPM=V	-10 +90 -10 +140 -10 +140
		1.5	1.5	5.1	0	9	6							

**DESCRIPTION**

Solenoid pilot 2 way normally closed. Tube Ø10 flange fixing.

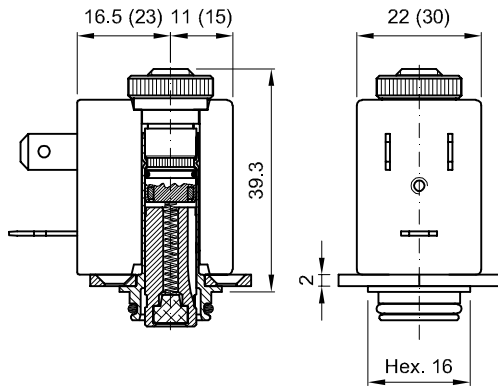

The quote in parenthesis are referred to the coil series 4

CODE		ØX mm	H mm	Differential pressure bar			Nominal power			Coil		Seal ①	Temp. range °C
Brass Tube	S.Steel Tube			Min	Max		AC Inrush	VA Holding	DC Watt	Series	Width		
					AC	DC							
E570...	E572...	1.2	5	0	25	25	12	8	6.5	3	22	NBR=B	-10 +90
		1.5	5.1	0	16	16							
		2	5.2	0	12	10							
		2.5	5.4	0	8	5.5							
		3.1	5.5	0	5	2							
E570...40	E572...40	4	5.6	0	4	1.5	15	11	5	4	30	EPDM=E	-10 +140
E570...	E572...	2	5.2	0	25	15							
		2.5	5.4	0	16	8							
		3.1	5.5	0	8	4							
E570...40	E572...40	4	5.6	0	5	2.5							

**DESCRIPTION**

Solenoid pilot 2 way normally open. Tube Ø10 flange fixing.

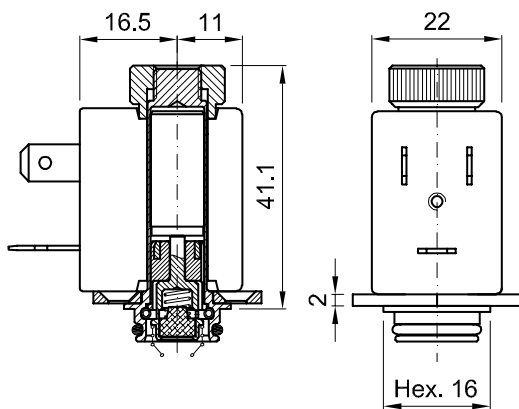

**7**

CODE		ØX mm	H mm	Differential pressure bar			Nominal power			Coil		Seal ①	Temp. range °C
Brass Tube	S.Steel Tube			Min	Max		AC Inrush	VA Holding	DC Watt	Series	Width		
					AC	DC							
E575...		1.2	5	0	19	19	12	8	6.5	3	22	NBR=B	-10 +90
		1.5	5.1	0	14	14							
		2	5.2	0	8	8							
		2.5	5.4	0	4.5	4.5							
		3.1	5.5	0	2.5	2.5							

**DESCRIPTION**

Solenoid pilot 3 way normally closed. Tube Ø10 flange fixing.

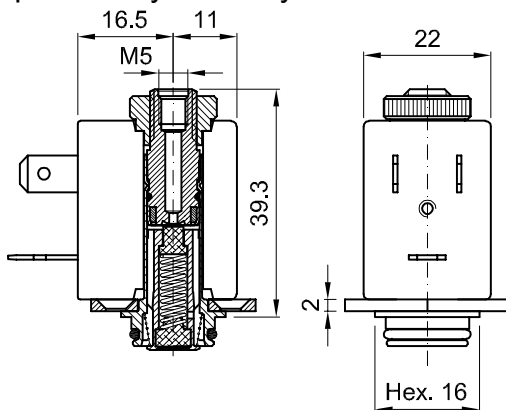

CODE		ØX mm	Øexh. mm	H mm	Differential pressure bar			Nominal power			Coil		Seal ①	Temp. range °C
Brass Tube	S.Steel Tube				Min	Max		AC Inrush	VA Holding	DC Watt	Series	Width		
E580...	E582...	1.2	1.5	5	0	15	15	12	8	6.5	3	22	NBR=B EPDM=E FPM=V	-10 +90
		1.5	1.5	5.1	0	10	10							-10 +140
		2	1.7	5.2	0	6	6							-10 +140

**DESCRIPTION**

Solenoid pilot 3 way normally open. Tube Ø10 flange fixing.

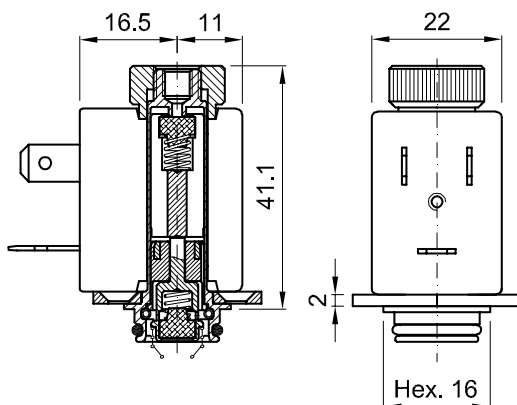

CODE		ØX mm	Øexh. mm	H mm	Differential pressure bar			Nominal power			Coil		Seal ①	Temp. range °C
Brass Tube	S.Steel Tube				Min	Max		AC Inrush	VA Holding	DC Watt	Series	Width		
E585...		1.2	1.5	5	0	12	8	12	8	6.5	3	22	NBR=B EPDM=E FPM=V	-10 +90
		1.5	1.5	5.1	0	9	6							-10 +140

**DESCRIPTION**

Solenoid pilot 2 way normally closed. Tube Ø13.

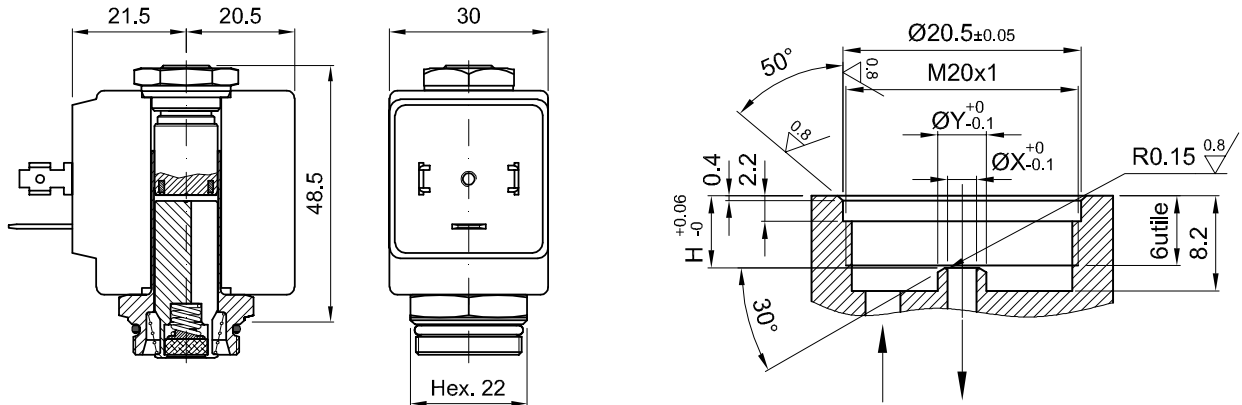

CODE	S.Steel Tube	ØX mm	H mm	ØY mm	Differential pressure bar		Nominal power			Coil		Temp. range °C		
					Min	Max	AC Inrush	VA Holding	DC Watt	Series	Width		Seal ①	
E610...		1.5	6.2	4.2	0	30	20	15	10	2	30	NBR=B EPDM=E FPM=V	-10 +90	
		2	6.2	4.2	0	22							20	-10 +140
		2.5	6.2	4.2	0	16							14	-10 +140
		3.5	6.2	6.2	0	10							8	-10 +140
		4.5	6.4	6.2	0	6.5							3.5	-10 +140
	5.2	6.4	6.2	0	4	1.8	-10 +140							

**DESCRIPTION**

Solenoid pilot 2 way normally open. Tube Ø13.

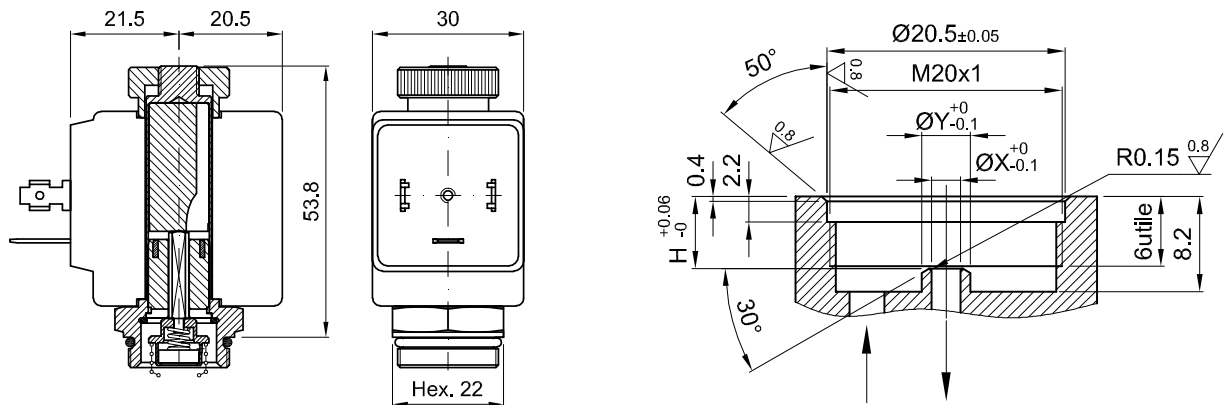

**7**

CODE	Brass Tube	S.Steel Tube	ØX mm	H mm	ØY mm	Differential pressure bar		Nominal power			Coil		Temp. range °C		
						Min	Max	AC Inrush	VA Holding	DC Watt	Series	Width		Seal ①	
E620...		E622	1.5	6.2	4.2	0	23	20	15	10	2	30	NBR=B EPDM=E FPM=V	-10 +90	
			2	6.2	4.2	0	17							17	-10 +140
			2.5	6.2	4.2	0	12							12	-10 +140
			3.5	6.2	6.2	0	7							4 ③	-10 +140
			4.5	6.4	6.2	0	4.5							3 ③	-10 +140
	5.2	6.4	6.2	0	3	2.2 ③	-10 +140								

## DESCRIPTION

Solenoid pilot 3 way normally closed. Tube Ø13.

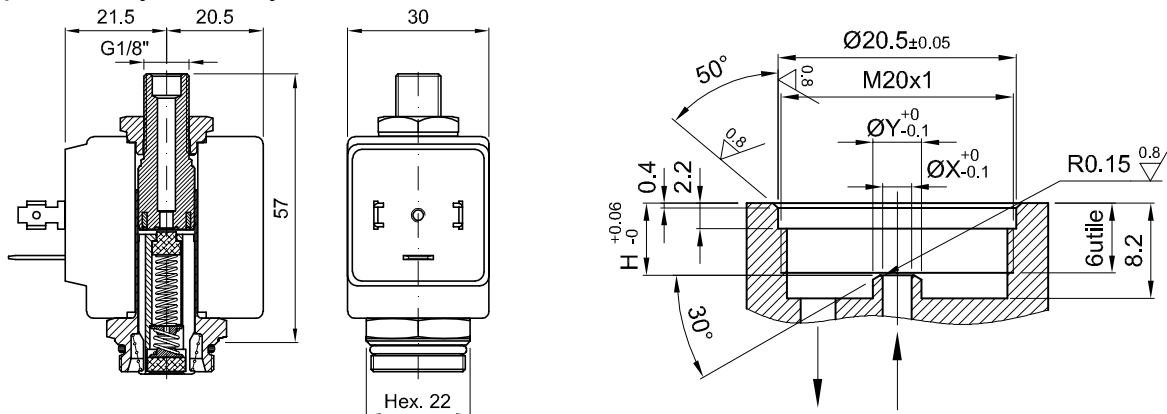

CODE S.Steel Tube	ØX mm	Øexh. mm	H mm	ØY mm	Differential pressure bar			Nominal power			Coil		Seal ①	Temp. range °C
					Min	Max		AC Inrush	VA Holding	DC Watt	Series	Width		
						AC	DC							
E630...	1.5	2.4	6.2	4.2	0	20	20	20	15	10	2	30	NBR=B EPDM=E FPM=V	-10 +90 -10 +140 -10 +140
	2	2.4	6.2	4.2	0	13	13							
	2.5	2.4	6.2	4.2	0	10	10							

## DESCRIPTION

Solenoid pilot 2 way normally closed. Tube Ø13 flange fixing.

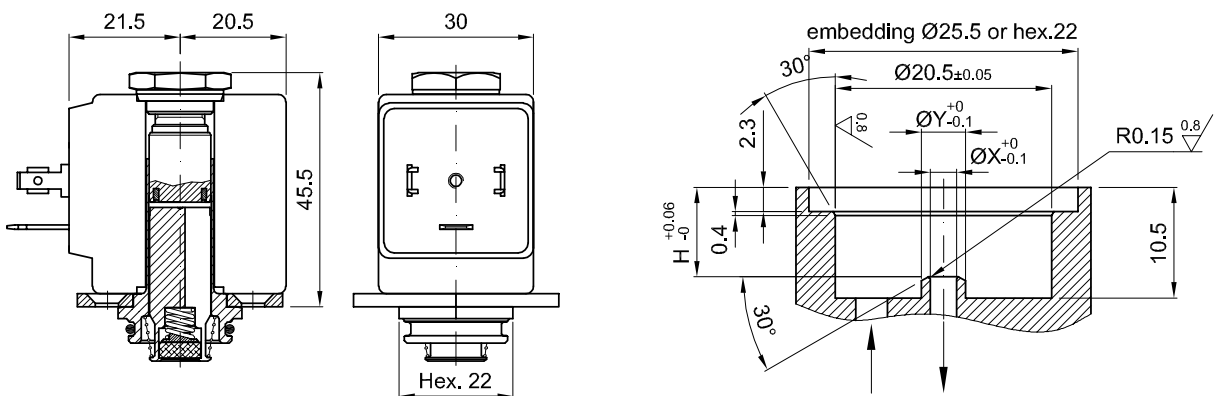

CODE S.Steel Tube	ØX mm	H mm	ØY mm	Differential pressure bar			Nominal power			Coil		Seal ①	Temp. range °C
				Min	Max		AC Inrush	VA Holding	DC Watt	Series	Width		
					AC	DC							
E670...	1.5	7.7	4.2	0	30	26	20	15	10	2	30	NBR=B EPDM=E FPM=V	-10 +90 -10 +140 -10 +140
	2	7.7	4.2	0	22	20							
	2.5	7.7	4.2	0	16	14							
	3.5	7.7	6.2	0	10	8							
	4.5	7.9	6.2	0	6.5	3.5							
5.2	7.9	6.2	0	4	1.8								



**DESCRIPTION**

Encapsulated coil incorporating the magnetic circuit.  
 Fixing by means of a central nut.  
 Electrical connection according to DIN 43650 A  
 (A EN 175301-803 ISO 4400)



**CONSTRUCTION**

Encapsulation:  
 Class F                      Fibre-glass Nylon  
 Class H                      Fibre-glass Polyarylamide  
 Magnetic circuit          Zinc-plated steel  
 Windings                    Copper covered with class H insulation

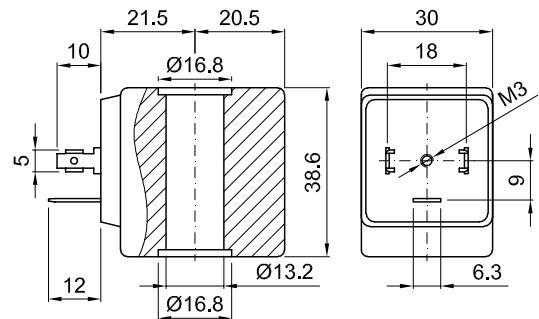

**OPTIONS:** Electrical connection through cable  
 Special powers and voltages  
 Self-extinguish

CODE		Alternating Current Voltage	Direct Current Voltage (V)	Power ①		Voltage tolerance		Connector	Service ED
Class F insulation	Class H insulation			Alternating Current (VA)	Direct Current (W)	Alternating current	Direct current		
20A	22A	12V 50/60Hz	-	15	-	+15%	-	10349000	100%
20B	22B	24V 50/60Hz	-						
20C	22C	48V 50/60Hz	-						
20D	22D	110V 50/60Hz	-						
20E	22E	220/230V 50/60Hz	-						
20F	22F	240V 50/60Hz	-						
20G	22G	380V 50/60Hz	-	-	10	-	±10%	10349000	100%
200	220	-	12						
201	221	-	24						
202	222	-	48						

Certified versions

NOTE: The performance with UL coil could be different. Please contact the manufacturer for any further information.

-	U25B	24V 60Hz	-	15	-	±10%	-	10349000	100%
-	U25D	120V 60Hz	-						
-	U25F	240V 60Hz	-						
-	U250	-	12	-	10	-	±10%	10349000	100%
-	U251	-	24						

① Considering nominal voltage and an ambient temperature of 20°C



**DESCRIPTION**

Encapsulated coil incorporating the magnetic circuit.  
 Fixing by means of a central nut.  
 Electrical connection according to DIN 43650 B  
 (B Industrial connection)



**CONSTRUCTION**

Encapsulation:  
 Class F                      Fibre-glass Nylon  
 Class H                      Fibre-glass Polyarylamide  
 Magnetic circuit          Zinc-plated steel  
 Windings                    Copper covered with class H insulation

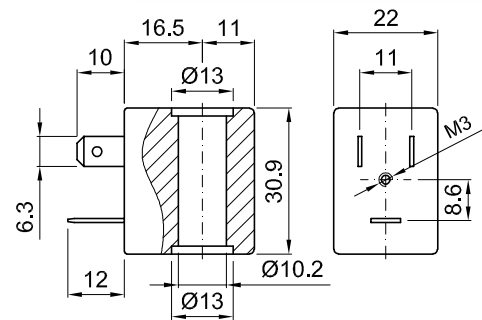

**OPTIONS:** Electrical connection through cable  
 Special powers and voltages  
 Self-extinguish

CODE		Alternating Current Voltage	Direct Current Voltage (V)	Power ①		Voltage tolerance		Connector	Service ED
Class F insulation	Class H insulation			Alternating Current (VA)	Direct Current (W)	Alternating current	Direct current		
30A	32A	12V 50/60Hz	-	8	-	+15%	-	10348000	100%
30B	32B	24V 50/60Hz	-						
30C	32C	48V 50/60Hz	-						
30D	32D	110V 50/60Hz	-						
30E	32E	220/230V 50/60Hz	-						
30F	32F	240V 50/60Hz	-						
30G	32G	380V 50/60Hz	-						
300	320	-	12	-	6.5	-	±10%		
301	321	-	24						
302	322	-	48						

8

Certified versions US

NOTE: The performance with UL coil could be different. Please contact the manufacturer for any further information.

-	U35B	24V 60Hz	-	8	-	±10%	-	10348000	100%
-	U35D	120V 60Hz	-						
-	U35F	240V 60Hz	-						
-	U350	-	12	-	6.5	-	±10%		
-	U351	-	24						

Certified versions

-	V32E	220/230	-	8	-	+15% -10%	-	10348000	100%
---	------	---------	---	---	---	--------------	---	----------	------

① Considering nominal voltage and an ambient temperature of 20°C



**DESCRIPTION**

Encapsulated coil incorporating the magnetic circuit.  
 Fixing by means of a central nut.  
 Electrical connection according to DIN 43650 A  
 (A EN 175301-803 ISO 4400)



**CONSTRUCTION**

Encapsulation:  
 Class F                      Fibre-glass Nylon  
 Class H                      Fibre-glass Polyarylamide  
 Magnetic circuit          Zinc-plated steel  
 Windings                    Copper covered with class H insulation

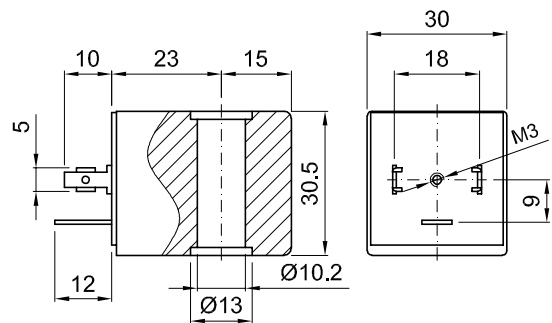

**OPTIONS:** Electrical connection through cable  
 Special powers and voltages  
 Self-extinguish

CODE		Alternating Current Voltage	Direct Current Voltage (V)	Power ①		Voltage tolerance		Connector	Service ED
Class F insulation	Class H insulation			Alternating Current (VA)	Direct Current (W)	Alternating current	Direct current		
40A	42A	12V 50/60Hz	-	11	-	+15%	-	10349000	100%
40B	42B	24V 50/60Hz	-						
40C	42C	48V 50/60Hz	-						
40D	42D	110V 50/60Hz	-						
40E	42E	220/230V 50/60Hz	-						
40F	42F	240V 50/60Hz	-						
40G	42G	380V 50/60Hz	-						
400	420	-	12	-	5	-	±10%	10349000	100%
401	421	-	24						
402	422	-	48						

8

Certified version US

NOTE: The performance with UL coil could be different. Please contact the manufacturer for any further information.

-	U450	-	12	-	8	-	±10%	10349000	100%
-	U451	-	24						

① Considering nominal voltage and an ambient temperature of 20°C



**DESCRIPTION**

Encapsulated coil incorporating the magnetic circuit.  
 Fixing by means of a central nut.  
 Electrical connection according to DIN 43650 A  
 (A EN 175301-803 ISO 4400)



**CONSTRUCTION**

Encapsulation:  
 Class H                      Fibre-glass Polyarylamide

Magnetic circuit              Zinc-plated steel

Windings                      Copper covered with class H insulation

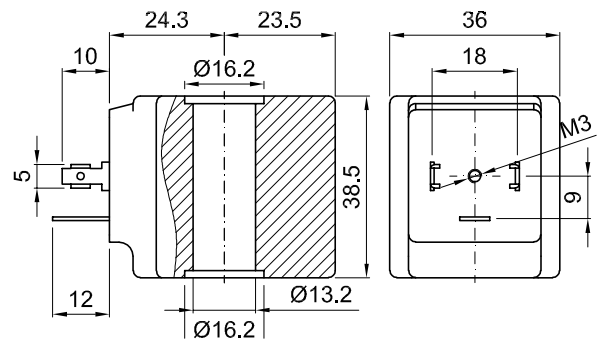

**OPTIONS:**    Electrical connection through cable  
                     Special powers and voltages  
                     Self-extinguish

CODE Class H insulation	Alternating Current Voltage	Direct Current Voltage (V)	Power ①		Voltage tolerance		Connector	Service ED
			Alternating Current (VA)	Direct Current (W)	Alternating current	Direct current		
52A	12V 50/60Hz	-	30	-	+15%	-	10349000	100%
52B	24V 50/60Hz	-						
52C	48V 50/60Hz	-						
52D	110V 50/60Hz	-						
52E	220/230V 50/60Hz	-						
52F	240V 50/60Hz	-						
52G	380V 50/60Hz	-						
520	-	12	-	27	-	±10%		
521	-	24						
522	-	48						

Certified version US

NOTE: The performance with UL coil could be different. Please contact the manufacturer for any further information.

U55B	24V 60Hz	-	20	-	±10%	-	10349000	100%
U55D	120V 60Hz	-						
U55F	240V 60Hz	-						
U550	-	12	-	14	-	±10%		
U551	-	24						

① Considering nominal voltage and an ambient temperature of 20°C





**DESCRIPTION**

Encapsulated coil incorporating the magnetic circuit.  
 Fixing by means of a central nut.  
 Electrical connection according to AMP 2.8x0.5.



**CONSTRUCTION**

Encapsulation:  
 Class F                      Fibre-glass Nylon

Magnetic circuit              Zinc-plated steel

Windings                      Copper covered with class H insulation

**OPTIONS:**      Electrical connection through cable  
                          Special powers and voltages  
                          Self-extinguish

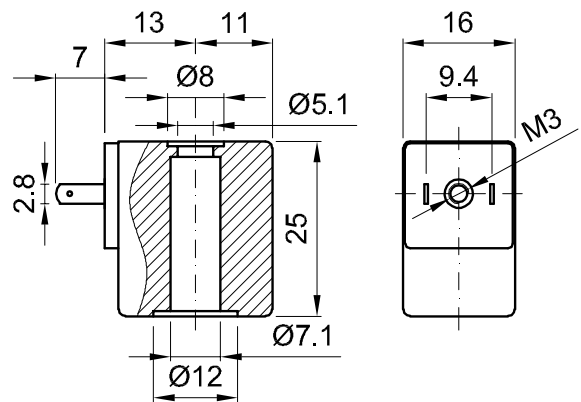

CODE Class F insulation	Direct Current Voltage (V)	Power ① Direct Current (W)	Voltage tolerance	Connector	Service ED
60014	12	4	±5%	10348040	100%
60048	12	8			25%
60114	24	4			100%
60148	24	8			25%
60012	12	2			100%
60112	24	2			100%

① Considering nominal voltage and an ambient temperature of 20°C



**DESCRIPTION**

Encapsulated coil in self-extinguish nylon incorporating a thermal resistor and a thermal fuse.

This design prevents any problems of overheating or sparking occurring making it particularly suitable for use in potentially explosive ambient.

**CONSTRUCTION**

- Encapsulation:  
Class F                      Self-extinguish Nylon
- Magnetic circuit        Zinc-plated steel
- Windings                Copper covered with class H insulation

**ELECTRICAL CONNECTION**

3-core cable length=300cm

**AMBIENT TEMPERATURE**

-20°C ÷ +40°C

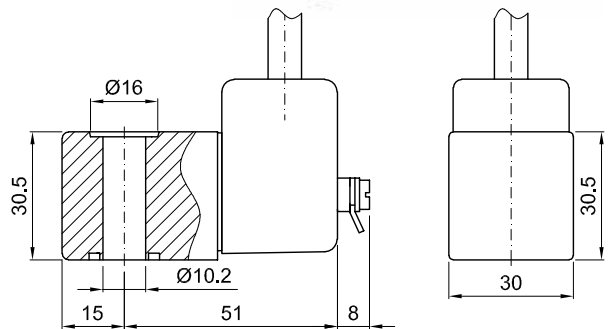

**CERTIFICATE**

Conforms to the European standards for the manufacturing of electrical components for use in potentially explosive atmospheres.

- EN 50014-1997+ A1...A2**
- E50025-1997, IEC 60079-18:2002**
- European Community Standard 97/9/CE**

**EEx m II T4 INERIS 06ATEX0002X  
CE 0080 Ex II 2 GD**

CODE	VOLTAGE	FREQUENCY	POWER ①
	Volt	Hz	W
75BD	24	50-60	5.3
75CD	48	50-60	5.3
75DD	110	50-60	5.2
75ED	230	50-60	5.2
751D	24 DC	-	5.4

① Considering nominal voltage and an ambient temperature of 20°C



## SINGLE BASE

Code:  
B01/340/M5

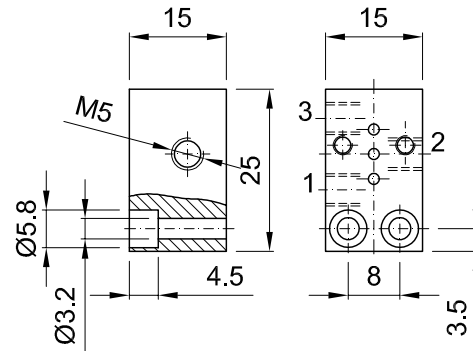

## MULTIPLE BASES

Code:  
B...../340/M5

N° PLACES

B...../340/R4

N° PLACES

\*=M5 thread

\*=quick connection  
for pipes  $\varnothing_{ext} 4$

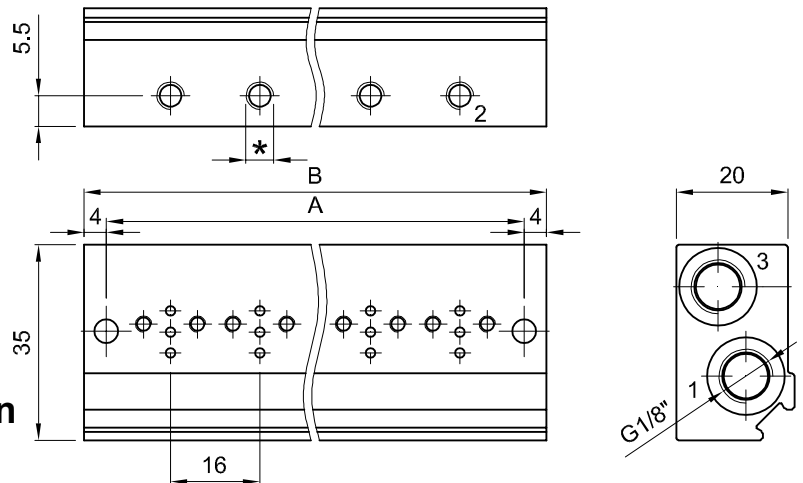

N° PLACES	2	3	4	5	6	7	8	9	10
A	39	55	71	87	103	119	135	151	167
B	47	63	79	95	111	127	143	159	175

## BLANKING PLATE

Code:  
PC/340

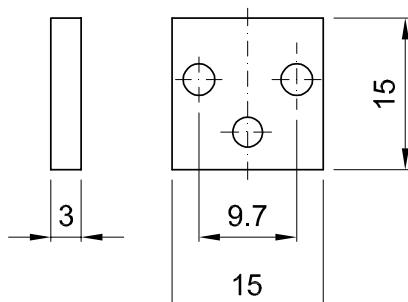

## REVERSING PLATE

Code:  
PA/340

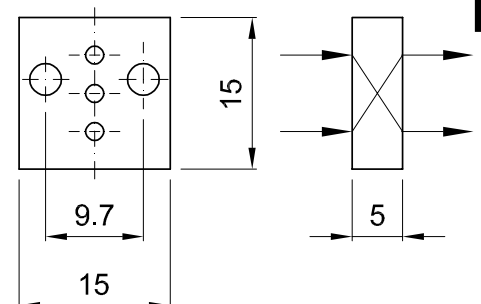

## SINGLE BASE

Code:  
B01/345/M5

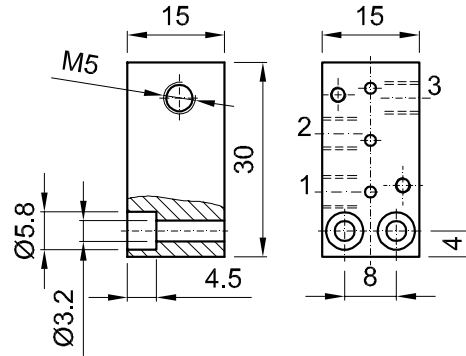

## MULTIPLE BASES

Code:

B...../345/M5

B...../345/R4

N° PLACES

N° PLACES

\*=M5 thread

\*=quick connection  
for pipes  $\varnothing_{ext} 4$

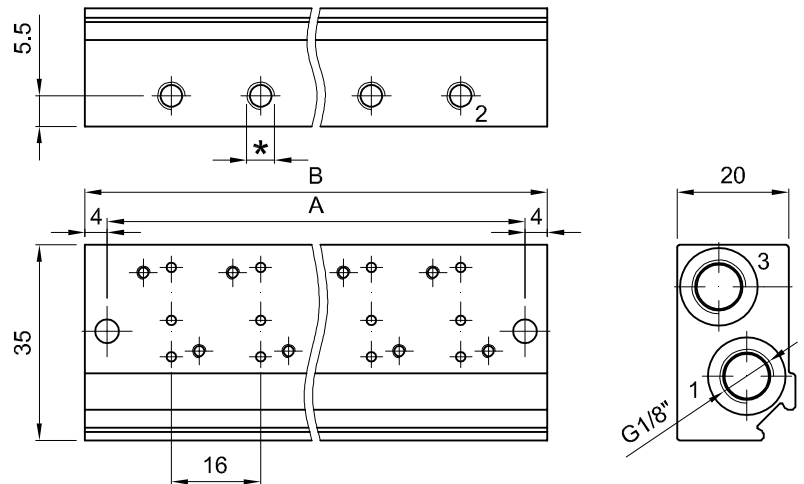

N° PLACES	2	3	4	5	6	7	8	9	10
A	39	55	71	87	103	119	135	151	167
B	47	63	79	95	111	127	143	159	175

## BLANKING PLATE

Code:

PC/345

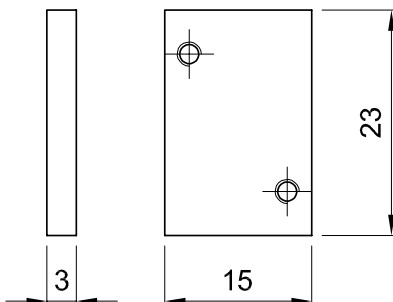

### Connector code 10349...

DIN 43650 Form A connector

Contact distance: 18mm  
 Protection class: IP65  
 Working temperature: -40°C +90°C  
 Fixing method: M3 central screw  
 Gland size: PG9 cable Ø6-8mm  
 code 10349000 (n°2 poles+earth)

PG11 cable Ø8-10mm  
 code 10349001 (n°2 poles+earth)

On request: PG9 cable Ø6-8mm  
 code 10349060 (n°3 poles+earth)

Weight 0.023Kg

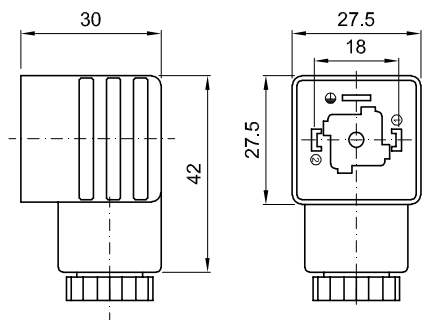

### Connector code 10348...

DIN 46244 Form B (DIN 43650 Form B) connector

Contact distance: 11mm  
 Protection class: IP65  
 Working temperature: -40°C +90°C  
 Fixing method: M3 central screw  
 Gland size: PG9 cable Ø6-8mm  
 code 10348000 (n°3 poles+earth)

Weight 0.019Kg

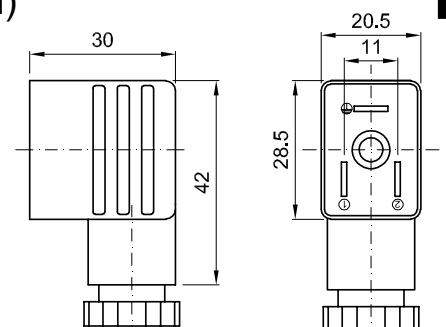

## Connector code 10348040

AMP 2.8x0.5 connector

Contact distance: 9.4mm  
 Protection class: IP65  
 Working temperature: -40°C +90°C  
 Fixing method: M3 central screw  
 Gland size: PG7 cable Ø4-6mm  
 (n°2 poles+earth)

Weight 0.010Kg

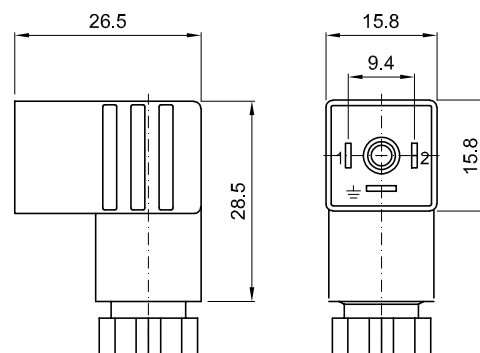

## Connector code 10348060

DIN 43650 Form C connector

Contact distance: 8mm  
 Protection class: IP65  
 Working temperature: -40°C +90°C  
 Fixing method: M2.5 central screw  
 Gland size: PG7 cable Ø4-6mm  
 (n°2 poles+earth)

Weight 0.010Kg

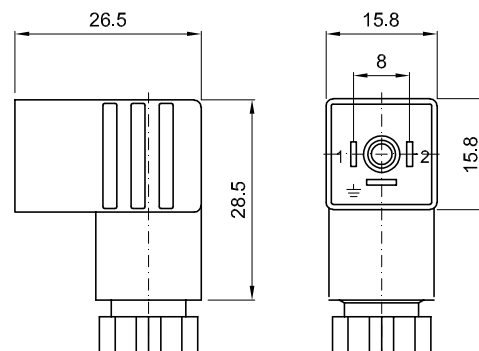



**Fixing kit for valves series 350-351**

**Code 11255000**

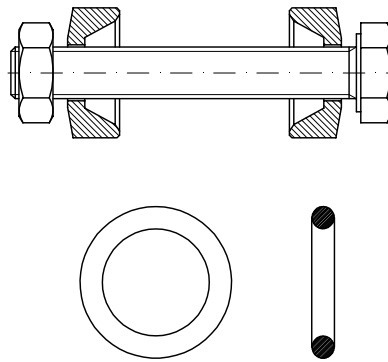

**Fixing flange for pilots series 570-580**

**Code 11092000**

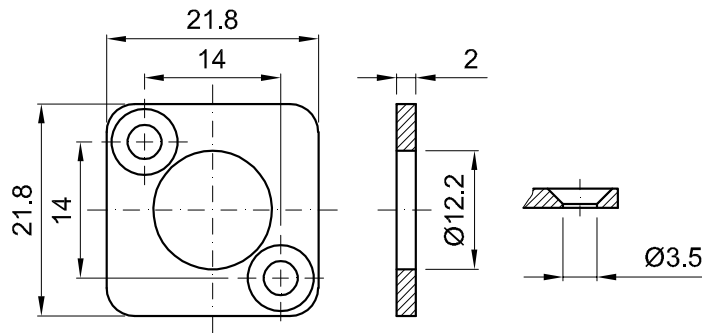

**Fixing flange for pilots series 570-580**

**Code 10984000**

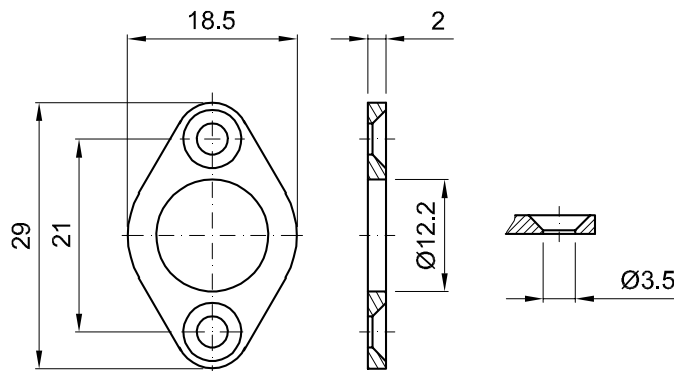

**Fixing flange for pilots series 670-680**

**Code 11260000**

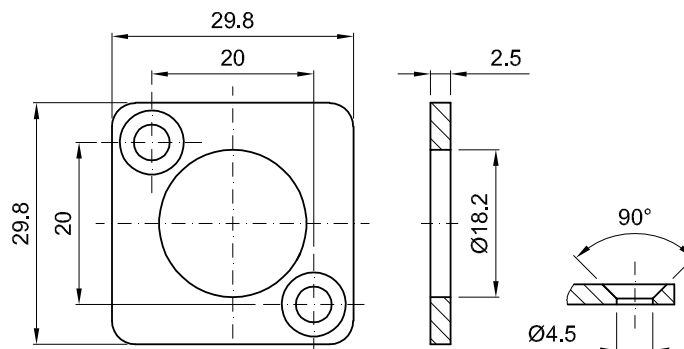

**Wet-proof coil fixing nut**

**For coil series 3 and 4 (solenoid valves 2/2NC)**

**Code 11003000**

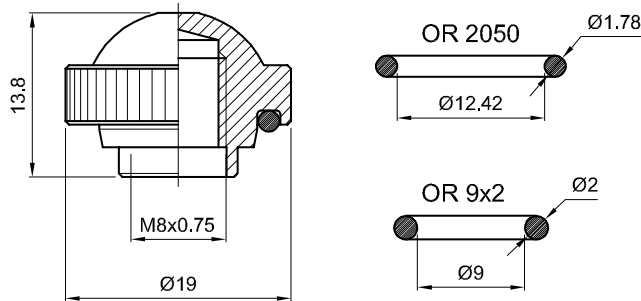

**For coil series 3 and 4 (solenoid valves 3/2NC)**

**Code 11586N00**

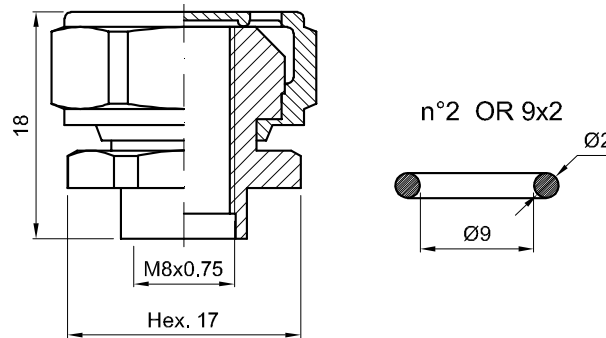

**For coil series 3 and 4 (solenoid valves 3/2NO)**

**Code 11587N00**

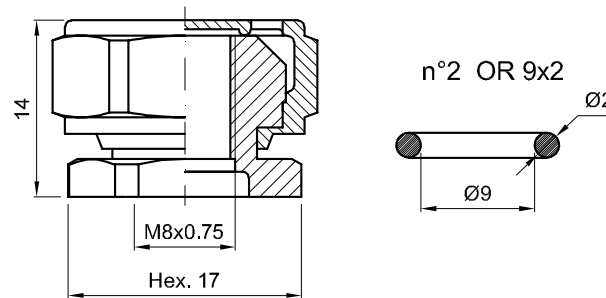

**For coil series 2 and 5 (solenoid valves 2/2NC)**

**Code 11002000**

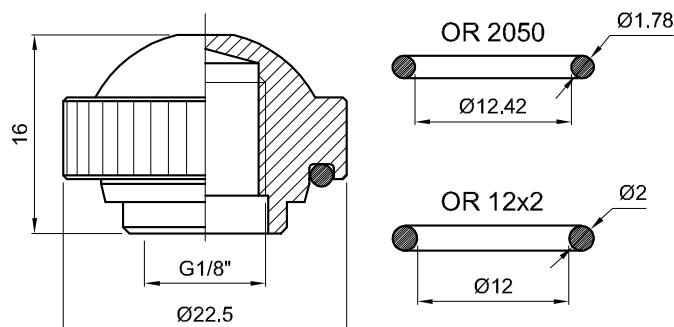



**FILTER BALL VALVE****Code 11322000 (G1/2" - G1/2")****Code 11322010 (G1/2" - G3/8")****CONSTRUCTION**

Body:	Brass chromium plated
Actuator:	Nylon
Filter:	Stainless steel
O-ring:	NBR

**FEATURES**

Connections:	G1/2" - G1/2" or G1/2" - G3/8"
Max working temperature:	+70°C (with water) +90°C (with air)



## DESCRIPTION

Multiple electrical connection unit with led indicators and safety circuit.  
 The unit can be equipped with solenoid valves series 340, 3/2NC and 3/2NO.  
 The solenoid valves can be assembled and tested on unit from 4 to 14 places.  
 The base has mutual inlets and mutual exhaust.  
 The user ports have quick connections for pipes  $\varnothing_{ext}$  4mm.  
 The energizing and de-energizing of the solenoid valves is showed by a led indicator.

## FEATURES

Media:	Clean compressed air (20um) with or without lubricant
Fixing method:	M4 screws
Pneumatic connections:	G1/8" for inlet and exhaust Quick connections for pipes $\varnothing_{ext}$ 4mm for user ports
Working pressure:	0,5 - 10bar for 3/2NC 0,5 - 8bar for 3/2NO
Ambient temperature:	-10°C +50°C
Protection class:	IP50
Electrical connection:	9 poles sub-D connector for units from 4 to 8 places 15 poles sub-D connector for units from 9 to 15 places

## CODE



**NOTE: This product isn't standard. POlease contact the manufacturer for any question**

## OVERALL DIMENSIONS

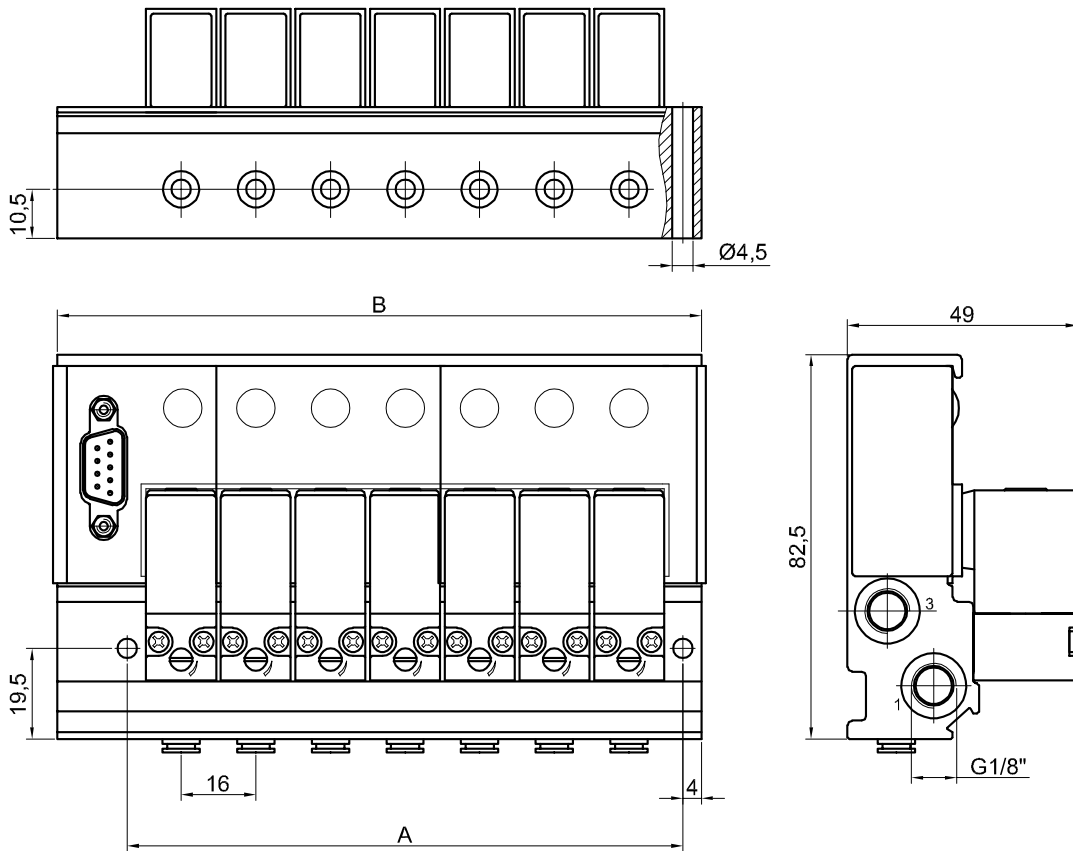

N° PLACES	4	5	6	7	8	9	10	11	12	13	14
A	71	87	103	119	135	151	167	183	199	215	231
B	93	109	125	141	157	173	189	205	221	237	253

## ELECTRICAL CONNECTION

### 4-8 PLACES UNIT

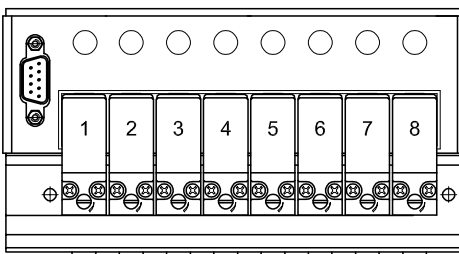
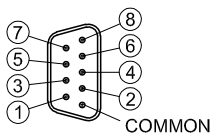

### 9-14 PLACES UNIT

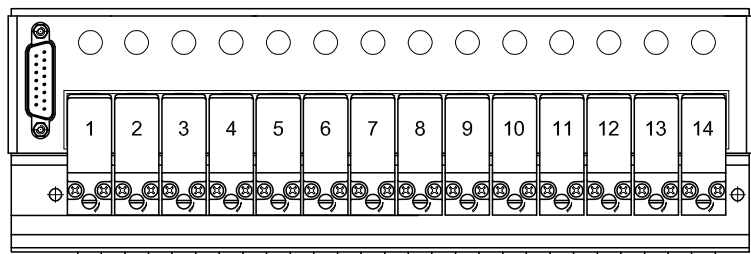
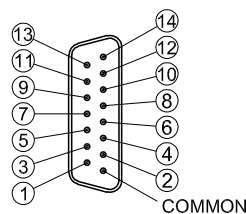

**Hosetail DN4  
Code P40B**

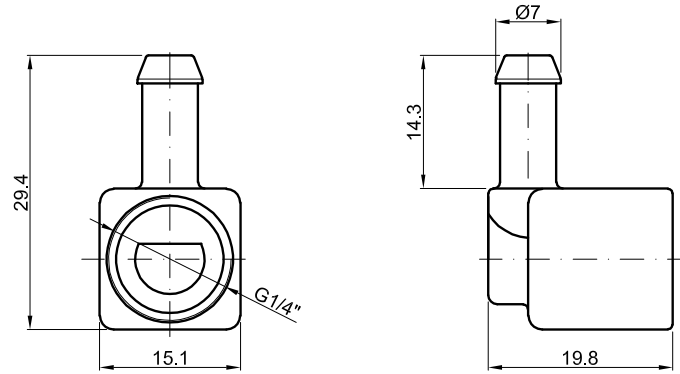

**Hosetail DN6  
Code P60B**

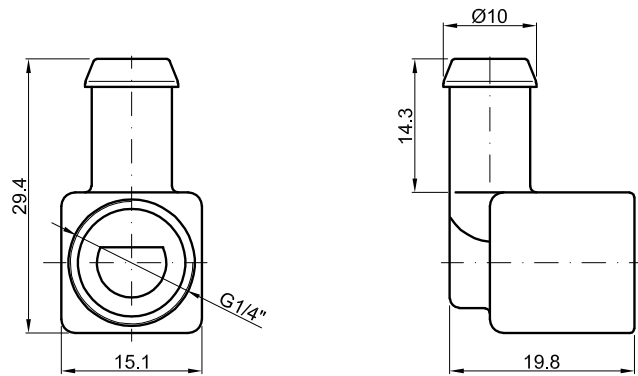

**Hosetail DN4 with flow regulator  
Code VP40B**

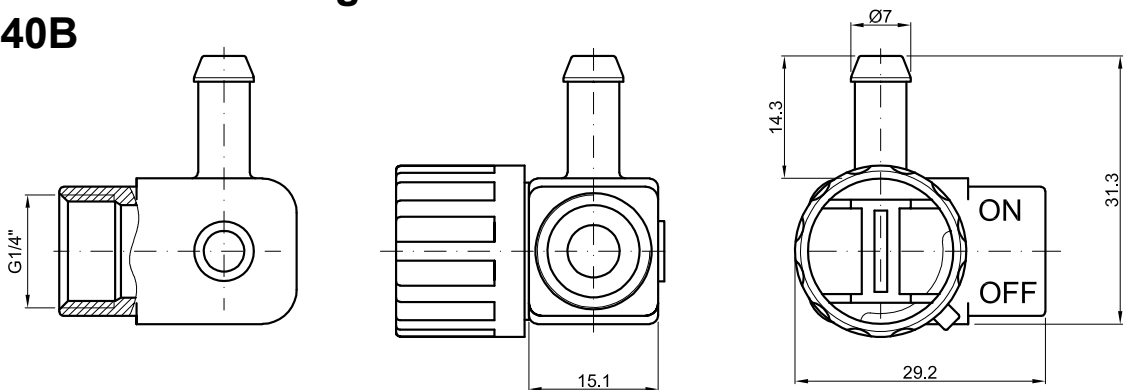

**Hosetail DN6 with flow regulator  
Code VP60B**

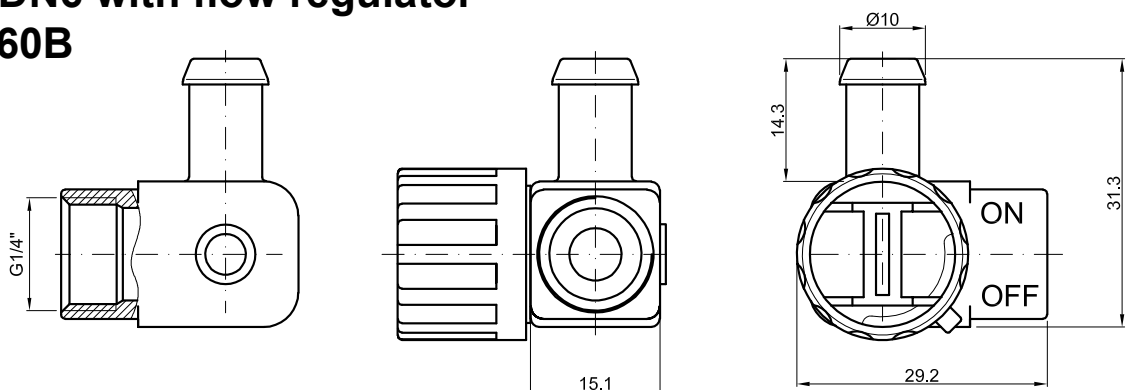





## 2/2NC and NO servo assisted diaphragm assembly

CODE	SEAL	VALVE SERIES
11030010	NBR	107B...10
11030020	FPM	107C...10
11030040	EPDM	207B...10 207C...10

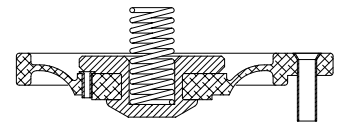

13386010	NBR	107C...12
13386020	FPM	107D...12
13386040	EPDM	207C...12 207D...12

13850010	NBR	107CB12/W 107DB12/W
----------	-----	------------------------

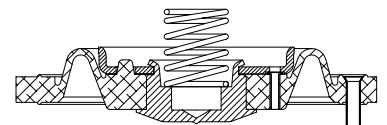

13850340	EPDM	107CE12/W 107DE12/W
----------	------	------------------------

13395010	NBR	107E
13395020	FPM	207E
13395040	EPDM	

13402010	NBR	107F
13402020	FPM	207F
13402040	EPDM	

11266010	NBR	107G
11266020	FPM	107H
11266040	EPDM	207G 207H

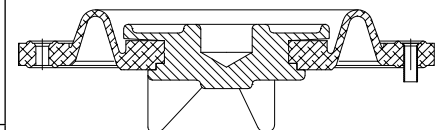

11267010	NBR	107I
11267020	FPM	207I
11267040	EPDM	

11269010	NBR	107M 107R 207M 207R
----------	-----	------------------------------

13744010	NBR	107M.../W 107R.../W 207M.../W 207R.../W
----------	-----	--

## 2/2NC assisted lift diaphragm assembly

CODE	SEAL	VALVE SERIES
13428020	FPM	E108C E108D
13429020	FPM	E108E
13430020	FPM	E108F

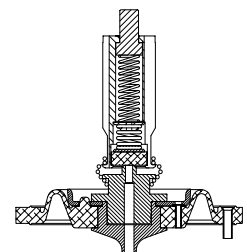

13431020	FPM	D108E
13432020	FPM	D108F

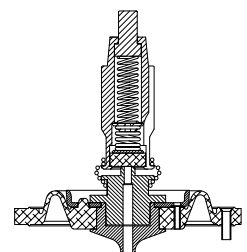

## 2/2 NO seal assembly for tube Ø10

CODE		SEAL	VALVE SERIES	
BRASS	S.STEEL		BRASS	S.STEEL
11166010	12104010	NBR FPM EPDM	205A	277C 277D 277E 277F
11166020	12104020		207C	
11166040	12104040		207D	
			207E	
			207F	
			212X	

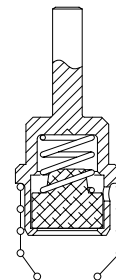

## 2/2 NO seal assembly for tube Ø13 (alternating current version)

CODE		SEAL	VALVE SERIES	
BRASS	S.STEEL		BRASS	S.STEEL
11167010	12916010	NBR FPM EPDM	E206...15	E210...15 E210...20 E210...25
11167020	12916020		E206...20	
11167040	12916040		E206...25	
			207G	
			207H	
			207I	
			207M	
			207R	
			E214X...15	
			E214X...20	
			E214X...25	
			219C	
			219D	
11176010	12003010	NBR FPM EPDM	E206...35	E210...35 E210...45 E210...52
11176020	12003020		E206...45	
11176040	12003040		E206...52	
			E214X...35	
			E214X...45	
			207M.../W	
			207R.../W	
12430010	13130010	NBR FPM EPDM	206...64	210...64
12430020	13130020			
12430040	13130040			

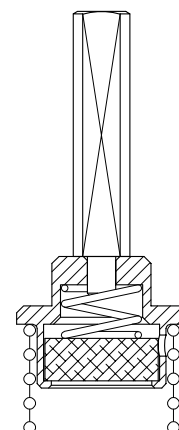

## 2/2 NO seal assembly for tube Ø13 (direct current version)

CODE		SEAL	VALVE SERIES	
BRASS	S.STEEL		BRASS	S.STEEL
13754010	12916010	NBR FPM EPDM	D206...15/3	D210...15 D210...20 D210...25
13754020	12916020		D206...20/3	
13754040	12916040		D206...25/3	
			D214X...15/5	
			D214X...20/5	
			D214X...25/5	
13755010	13756010	NBR FPM EPDM	D206...35/3	D210...35/3 D210...45/3 D210...52/3
13755020	13756020		D206...45/3	
13755040	13756040		D206...52/3	
			D214X...35/5	
			D214X...45/5	

## 2/2NC with dry armature diaphragm

CODE	SEAL	VALVE SERIES
10402030	SILICONE	150
11315030	SILICONE	160 161

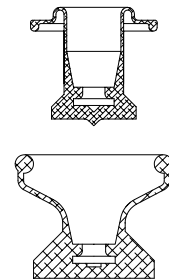

## Diverting valve with dry armature diaphragm

CODE	SEAL	VALVE SERIES
10664010	NBR	330

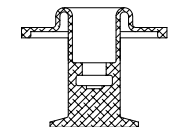

## 2/2 NC Ø6.35 plunger

CODE	SEAL	VALVE SERIES
1046301A 1046302A 1046304A	NBR	121

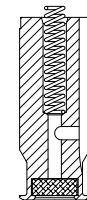

## 2/2 NC Ø9 plunger

CODE	SEAL	VALVE SERIES
11799010 11799020 11799040	NBR* FPM EPDM*	105 135 107C-107D-107E-107F 111 112 510-512
11800010 11800020 11800040	NBR* FPM EPDM*	105-135 (only Ø4)

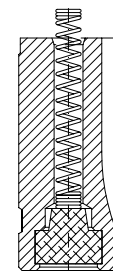

## 2/2 NC Ø11.85 plunger (up to orifice Ø5.2)

CODE	SEAL	VALVE SERIES
10120010 10120020 10120040	NBR* FPM EPDM*	106 107G-107H-107I 114X 119C-119D 610
10120N10 10120N20 10120N40	NBR* FPM EPDM*	110

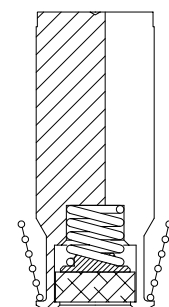

## 2/2 NC Ø11.85 plunger (orifice Ø6.4)

CODE	SEAL	VALVE SERIES
11035010 11035020 11035040 12004050	NBR* FPM EPDM* PTFE	106 110

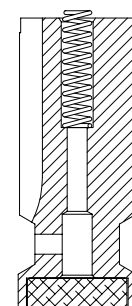

\* Food approval certified material on request

## 3/2 NC Ø9 plunger

CODE	SEAL	VALVE SERIES
10492010	NBR	305 (Ø1.2)
10492020	FPM	311 (Ø1.2)
10492040	EPDM	312 (Ø1.2)
10519010	NBR	305
10519020	FPM	335
10519040	EPDM	311
		312
		530
		532

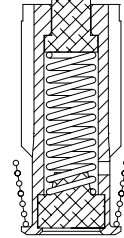

## 3/2 NO Ø9 plunger (inlet from the core)

CODE	SEAL	VALVE SERIES
11289010	NBR	305
11289020	FPM	311
11289040	EPDM	312

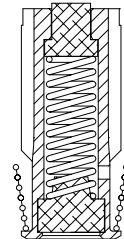

## 3/2 UNIVERSAL SERVICE Ø9 plunger (NC and NO)

CODE	SEAL	VALVE SERIES
11291010	NBR	305
11291020	FPM	311
11291040	EPDM	312

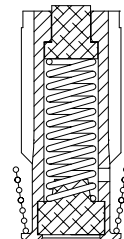

## 3/2 NC Ø11.85 plunger

CODE	SEAL	VALVE SERIES
10966010	NBR	203
10966020	FPM	306
10966040	EPDM	314
		630
10966N10	NBR	310
10966N20	FPM	
10966N40	EPDM	

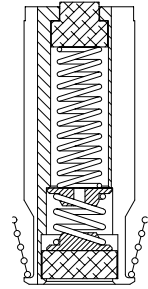

## 3/2 NO Ø11.85 plunger (inlet from the core)

CODE	SEAL	VALVE SERIES
11045010	NBR	306
11045020	FPM	314
11045040	EPDM	
11045N10	NBR	310
11045N20	FPM	
11045N40	EPDM	

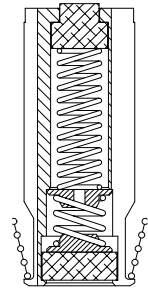

## 3/2 UNIVERSAL SERVICE Ø11.85 plunger (NC and NO)

CODE	SEAL	VALVE SERIES
11044010	NBR	306
11044020	FPM	314
11044040	EPDM	
11044N10	NBR	310
11044N20	FPM	
11044N40	EPDM	

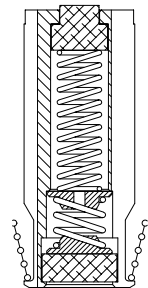

## 2/2 NC Ø11.85 plunger

CODE	SEAL	VALVE SERIES
10343010 10343020 10343040	NBR FPM EPDM	109C 109D
10344010 10344020 10344040	NBR FPM EPDM	109E

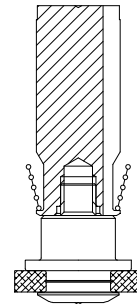

## 2/2 NC and NO piston assembly

CODE	SEAL	VALVE SERIES
12735000	FPM/PTFE	119 219

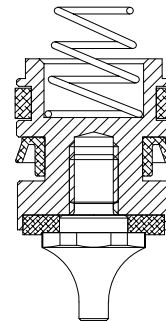

## 2/2 NC for steam (up to 180°C) piston assembly

CODE	SEAL	VALVE SERIES
11910000	PTFE	119W

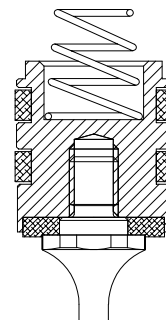

## 2/2 NC Ø10 brass armature tube (for AC and DC)

CODE	SEAL	VALVE SERIES
10128010	NBR	105
10128020	FPM	112
10128040	EPDM	

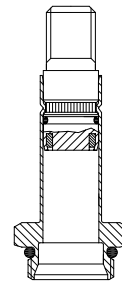

## 2/2 NC Ø10 stainless steel armature tube (for AC and DC)

CODE	SEAL	VALVE SERIES
10128SI10	NBR	107B-107C-107D-107E
10128SI20	FPM	107F-107G(Ø30)
10128SI40	EPDM	177 111

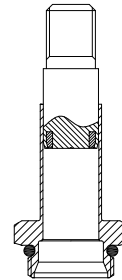

## 2/2 NC Ø10 nickel-plated brass armature tube (for AC and DC) Flange fixing

CODE	SEAL	VALVE SERIES
11762K10	NBR	135
11762K20	FPM	
11762K40	EPDM	

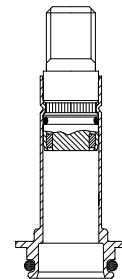

## 2/2 NC Ø10 brass armature tube (for DC)

CODE	SEAL	VALVE SERIES
10219010	NBR	D105 D112
10219020	FPM	
10219040	EPDM	

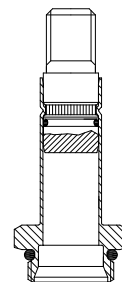

## 2/2 NC Ø10 stainless steel armature tube (for DC)

CODE	SEAL	VALVE SERIES
10219SI10	NBR	D107B-D107C-D107D- D107E D107F-D107G(Ø30) D177 D111
10219SI20	FPM	
10219SI40	EPDM	

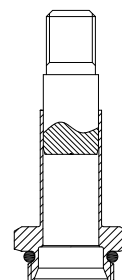

## 3/2 NC Ø10 brass armature tube (for AC and DC)

### Hole Ø1

CODE	SEAL	VALVE SERIES
10340210	NBR	305A
10340220	FPM	312X
10340240	EPDM	

### Hole Ø1.5

CODE	SEAL	VALVE SERIES
10340010	NBR	305A
10340020	FPM	312X
10340040	EPDM	

### Hole Ø1.7

CODE	SEAL	VALVE SERIES
10340110	NBR	305A
10340120	FPM	312X
10340140	EPDM	

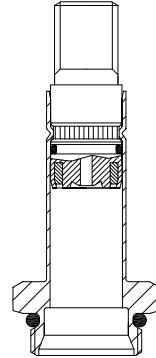

## 3/2 NC Ø10 brass armature tube (for DC)

### Hole Ø1

CODE	SEAL	VALVE SERIES
10341210	NBR	D305A
10341220	FPM	D312X
10341240	EPDM	

### Hole Ø1.5

CODE	SEAL	VALVE SERIES
10341010	NBR	D305A
10341020	FPM	D312X
10341040	EPDM	

### Hole Ø1.7

CODE	SEAL	VALVE SERIES
10341110	NBR	D305A
10341120	FPM	D312X
10341140	EPDM	

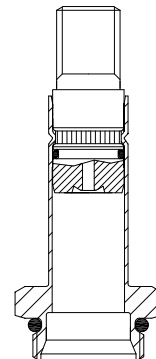



## 3/2 NC Ø10 stainless steel armature tube (for AC and DC)

### Hole Ø1

CODE	SEAL	VALVE SERIES
10340SI210	NBR	305A
10340SI220	FPM	311A*
10340SI240	EPDM	312X

### Hole Ø1.5

CODE	SEAL	VALVE SERIES
10340SI010	NBR	305A
10340SI020	FPM	311A*
10340SI040	EPDM	312X

### Hole Ø1.7

CODE	SEAL	VALVE SERIES
10340SI110	NBR	305A
10340SI120	FPM	311A*
10340SI140	EPDM	312X

\* for silver shading ring versions contact the manufacturer

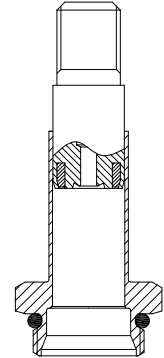

## 3/2 NC Ø10 stainless steel armature tube (for DC)

### Hole Ø1

CODE	SEAL	VALVE SERIES
10341SI210	NBR	D305A
10341SI220	FPM	D312X
10341SI240	EPDM	

### Hole Ø1.5

CODE	SEAL	VALVE SERIES
10341SI010	NBR	D305A
10341SI020	FPM	D312X
10341SI040	EPDM	

### Hole Ø1.7

CODE	SEAL	VALVE SERIES
10341SI110	NBR	D305A
10341SI120	FPM	D312X
10341SI140	EPDM	

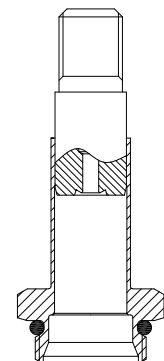

## 2/2 NC Ø13 stainless steel armature tube (for AC and DC)

CODE	SEAL	VALVE SERIES
12456010	NBR	106
12456020	FPM	107G(Ø37) - 107H
12456040	EPDM	107I - 107M - 107R
		E108
		109
		110*
		114
		119
		320

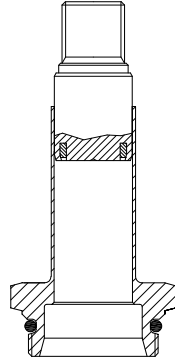

\* for silver shading ring versions contact the manufacturer

## 2/2 NC Ø13 stainless steel armature tube (for DC)

CODE	SEAL	VALVE SERIES
12457010	NBR	D106
12457020	FPM	D107G(Ø37) - D107H
12457040	EPDM	D107I - D107M - D107R
		D108
		D109
		D110
		D114
		D119
		D320

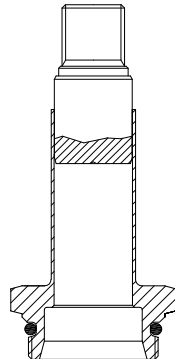

## 2/2 NC Ø13 stainless steel armature tube for D108 G3/4" and G1"

CODE	SEAL	VALVE SERIES
12465020	FPM	D108E D108F

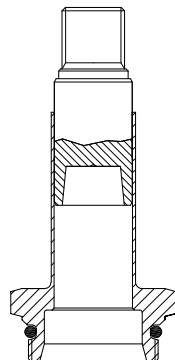

## 3/2 NC Ø13 stainless steel armature tube (for AC and DC)

### Hole Ø2

CODE	SEAL	VALVE SERIES
12464110	NBR	306
12464120	FPM	310*
12464140	EPDM	314

### Hole Ø2.4

CODE	SEAL	VALVE SERIES
12464010	NBR	306
12464020	FPM	310*
12464040	EPDM	314

### Hole Ø2.8

CODE	SEAL	VALVE SERIES
12464210	NBR	306
12464220	FPM	310*
12464240	EPDM	314

\* for silver shading ring versions contact the manufacturer

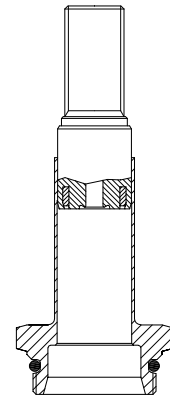

## 3/2 NC Ø13 stainless steel armature tube (for DC)

### Hole Ø2

CODE	SEAL	VALVE SERIES
12462110	NBR	D306
12462120	FPM	D310
1246240	EPDM	D314

### Hole Ø2.4

CODE	SEAL	VALVE SERIES
12462010	NBR	D306
12462020	FPM	D310
12462040	EPDM	D314

### Hole Ø2.8

CODE	SEAL	VALVE SERIES
12462210	NBR	D306
12462220	FPM	D310
12462240	EPDM	D314

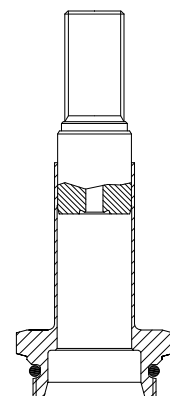

## 2/2 NO Ø10 armature tube (for AC and DC)

CODE		SEAL	VALVE SERIES	
BRASS	S.STEEL		BRASS	S.STEEL
11170010	11170SI10	NBR FPM EPDM	E205A E212X	E205A
11170020	11170SI20			207C - 207D
11170040	11170SI40			207E - 207F

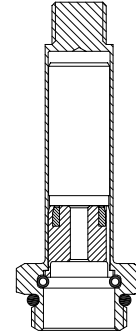

## 2/2 NO Ø10 armature tube (for DC)

CODE		SEAL	VALVE SERIES	
BRASS	S.STEEL		BRASS	S.STEEL
11171010	11171SI10	NBR FPM EPDM	D205A D212X	D205A
11171020	11171SI20			D207C - D207D
11171040	11171SI40			D207E - D207F

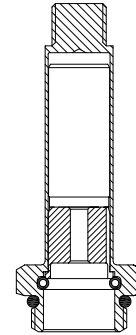

## 3/2 NO Ø10 brass armature tube (for AC and DC)

CODE	SEAL	VALVE SERIES
11174010	NBR FPM EPDM	307A 312X
11174020		
11174040		

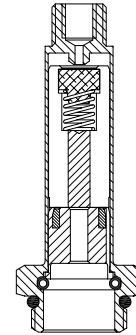

## 3/2 NO Ø10 brass armature tube (for DC)

CODE	SEAL	VALVE SERIES
11175010	NBR FPM EPDM	D307A D312X
11175020		
11175040		

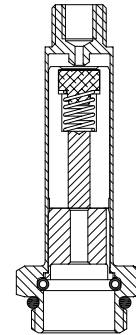

## 2/2 NC Ø13 armature tube (for AC and DC)

CODE		SEAL	VALVE SERIES	
BRASS	S.STEEL		BRASS	S.STEEL
11172010	11172SI10	NBR FPM EPDM	E206	E206
11172020	11172SI20		E214X	E214X
11172040	11172SI40		207G	207G
			207H	207H
			207I	207I
			207M	207M
			207R	207R
			219	219

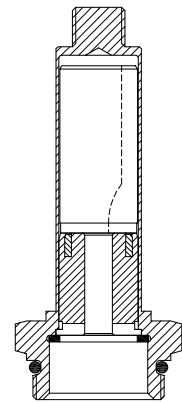

## 2/2 NC Ø13 armature tube (for DC)

CODE		SEAL	VALVE SERIES	
BRASS	S.STEEL		BRASS	S.STEEL
11173010	11173SI10	NBR FPM EPDM	D206	D206
11173020	11173SI20		D214X	D214X
11173040	11173SI40		D207G	D207G
			D207H	D207H
			D207I	D207I
			D207M	D207M
			D207R	D207R
			D219	D219

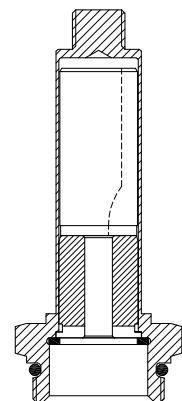

---

**COIL FIXING NUT**

---

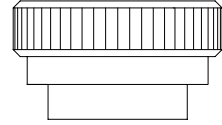
**Code 10203000****Coil fixing nut for series 3 and series 4  
2/2NC and 3/2NC solenoid valves  
with brass tube**

---

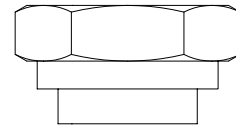
**Code 11643K0A****Coil fixing nut for series 3 and series 4  
2/2NC and 3/2NC solenoid valves  
with stainless steel tube**

---

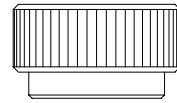
**Code 1012600B****Coil fixing nut for series 3 and series 4  
2/2NO and 3/2NO solenoid valves**

---

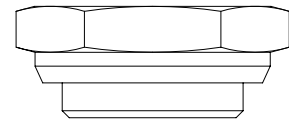
**Code 10097000****Coil fixing nut for series 2 and series 5  
2/2NC and 3/2NC solenoid valves**

---

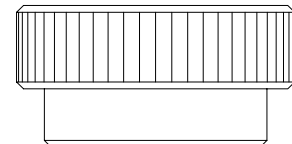
**Code 10293000****Coil fixing nut for series 2 and series 5  
2/2NO solenoid valves**

---

**Code 10464000****Coil fixing nut for series 6**





20873 Cavenago di Brianza (MB) Italy Via Giovanni Falcone,6 Tel. +39 02 9501335 Fax +39 02 95 335041 E-mail: [infoacl@acl.it](mailto:infoacl@acl.it) <http://www.acl.it>

